

LETTERING TO BE
CAST FLUSH WITH TOP
OF LID. POSITION
AS SHOWN

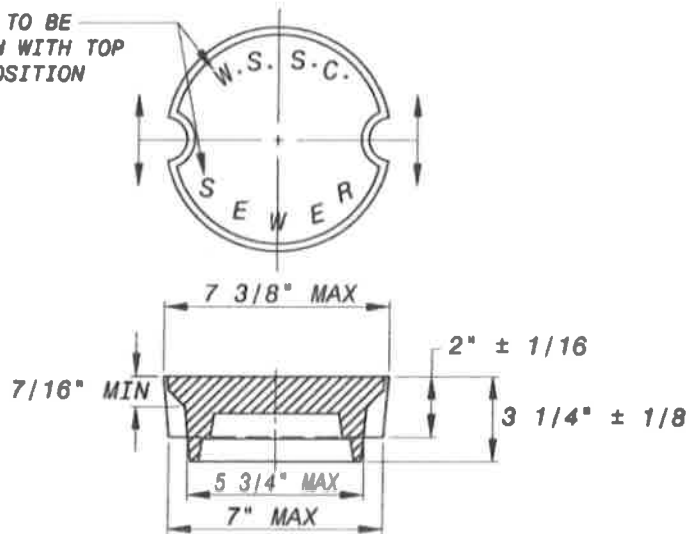

COVER

WEIGHT : 12 1/2 LBS MIN.

- SECTION TO BE GRAY IRON CASTING, ASTM A-48 CLASS NO. 25 MIN.
- ALL CASTINGS ARE TO BE CLEANED BY AN APPROVED PROCESS AND COATED WITH AN APPROVED ASPHALTUM OR COAL TAR PAINT.

APPLICABLE STOCK NO.
4881-9006-7

WASHINGTON SUBURBAN SANITARY COMMISSION	REVISIONS:	PROCUREMENT AND MANUFACTURING DETAIL	ADJUSTABLE VALVE BOX COVER MARKED SEWER (ALSO USED AS COVER FOR 4" SEWER CLEANOUT FRAME)	P&M 1.2
	APPROVED: <i>[Signature]</i> 10/28/14 MATERIAL AND SERVICES GROUP LEADER			