

TOP OF COMPACTED EMBANKMENT MINIMUM 1' ABOVE TOP OF STONE LINING, MAXIMUM 5' ABOVE EXISTING GROUND

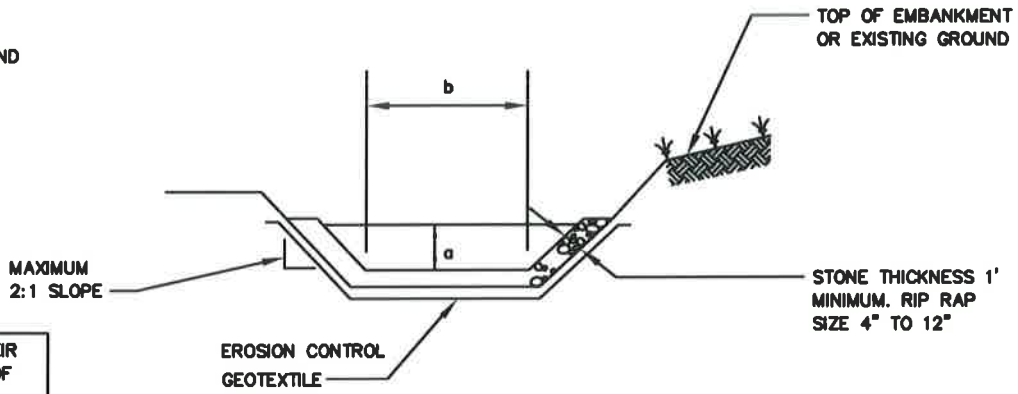

BOTTOM WIDTH OF WEIR (b) MINIMUM DEPTH OF CHANNEL (a)

CROSS SECTION

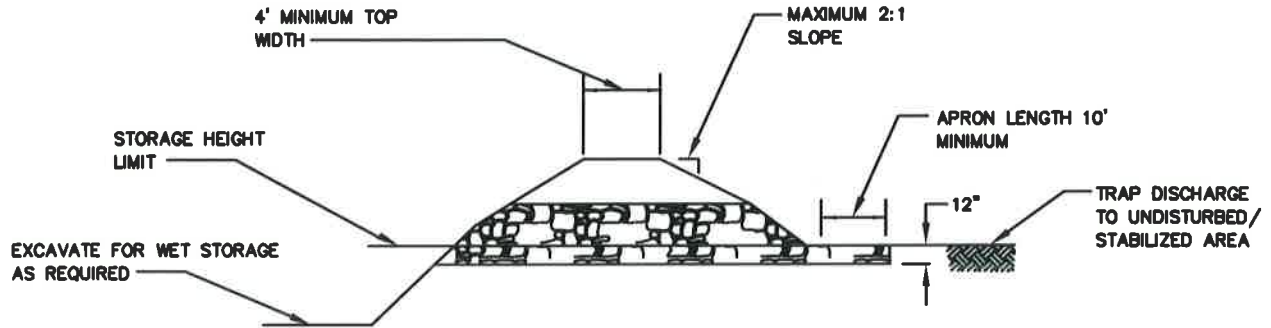

GEOTEXTILE SHALL BE EMBEDDED AT LEAST 6" INTO THE EXISTING GROUND AT ENTRANCE TO THE OUTLET CHANNEL

PROFILE

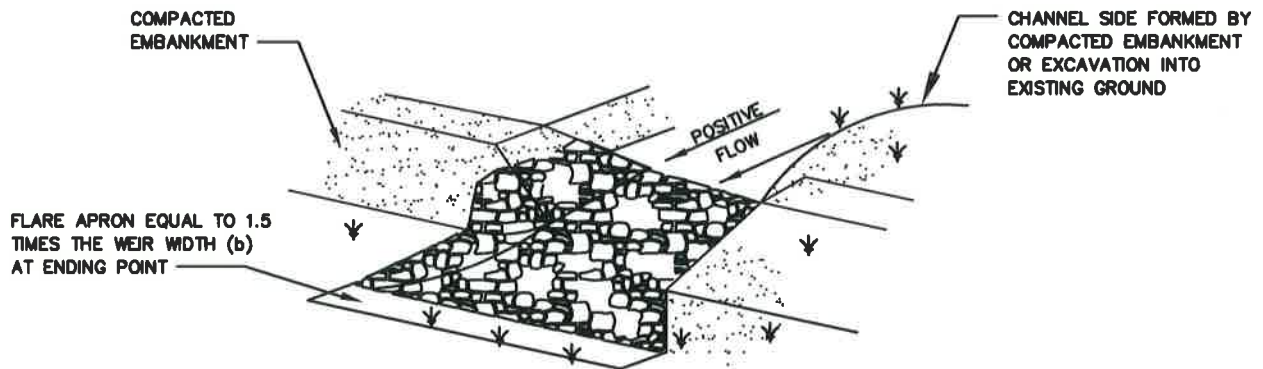

ROST

PERSPECTIVE

WASHINGTON
SUBURBAN
SANITARY
COMMISSION

APPROVED: 8/15/76

Chief Engineer

STANDARD DETAIL
RIPRAP OUTLET
SEDIMENT
TRAP

SC
4.0