

PLAN

TEES, INCLUDING PRESSURE SHC'S

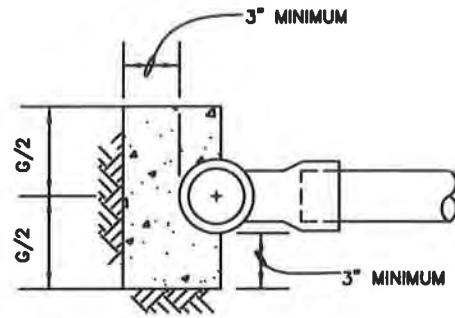

SECTION A-A

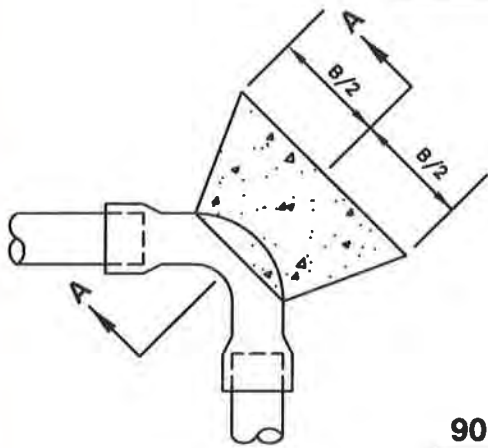

PLAN

90 ° HORIZONTAL BENDS

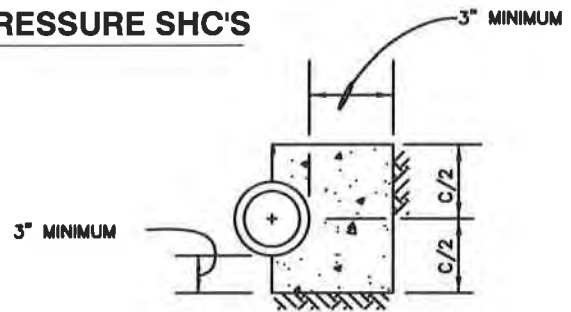

SECTION A-A

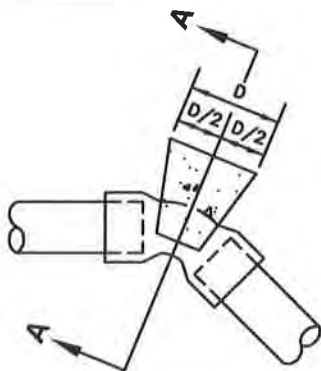

PLAN

11-1/4°, 22-1/2°, 45° HORIZONTAL AND LOWER VERTICAL BENDS

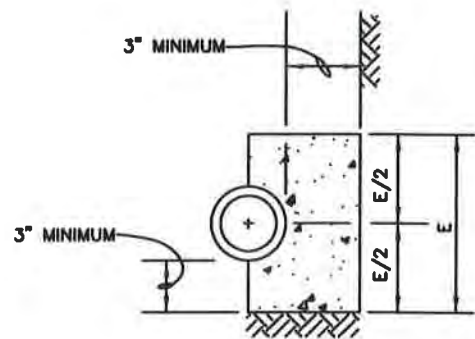

SECTION A-A

PIPE SIZE	B	C	D	E	F	G
1-1/4" AND 1-1/2"	8"	8"	5"	5"	6"	6"
2"	10"	10"	7"	7"	10"	10"
2-1/2"	10"	10"	7"	7"	10"	10"
3"	12"	12"	9"	9"	12"	12"
4"	26"	12"	12"	12"	18"	12"

NOTES:

1. $f'_c=3000$ psi @ 28 DAYS.
2. CARRY ALL BEARING SURFACES TO UNDISTURBED GROUND OR FIRM SUBGRADE.
3. BUTTRESS SIZED FOR 150 psi.
4. SEE DETAIL PS/1.42 FOR UPPER VERTICAL BENDS.
5. DO NOT ENCASE JOINTS.

WASHINGTON
SUBURBAN
SANITARY
COMMISSION

APPROVED: 8/18/16

Chief Engineer

STANDARD DETAIL
PRESSURE SEWER
BLOCKING DETAILS

PS
1.4