

IN LINE VALVE BONDING

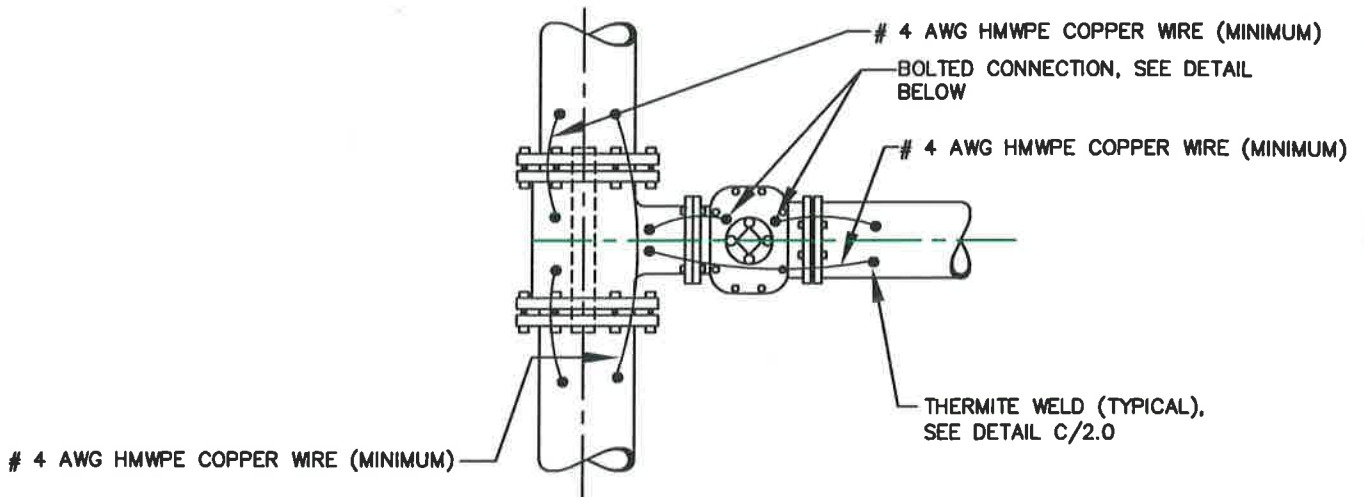

TEE OR TAPPING SLEEVE AND VALVE BONDING

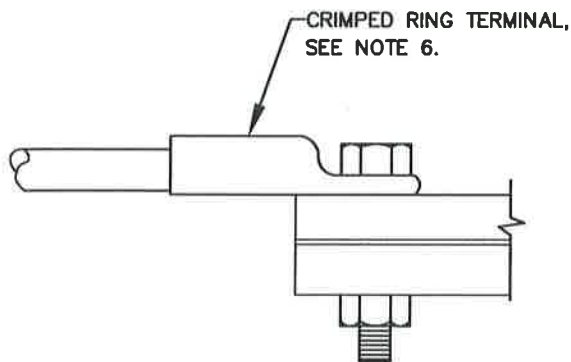

BOLTED CONNECTION

NOTES:

1. SEE DETAIL C/1.0 FOR BOND WIRE SIZE AND INSULATION.
2. CLEAN VALVE TO BRIGHT METAL AT POINT OF BOLTED CONNECTION.
3. ENSURE BOLT AND WIRE CRIMP ARE FREE OF DIRT AND SCALE TO CREATE PROPER METAL TO METAL CONTACT FOR BONDING.
4. AFTER CONNECTIONS ARE MADE, COAT EXPOSED METAL WITH SCOTCHKOTE OR APPROVED EQUAL.
5. SEE DETAIL C/1.0 FOR JOINT BONDING OF PUSH-ON JOINTS.
6. CRIMPED RING TERMINAL ON BOLTED CONNECTION DEPENDENT ON SIZE OF WIRE.

WASHINGTON
SUBURBAN
SANITARY
COMMISSION

APPROVED: 8/12/16

Chief Engineer

STANDARD DETAIL
DUCTILE IRON
MECHANICAL JOINT
VALVE BONDING

C
1.2