

TWO WIRES, MAXIMUM WIRE LENGTH = 24",
 TWO WIRES, MINIMUM WIRE LENGTH = 18",
 SEE SIZES BELOW

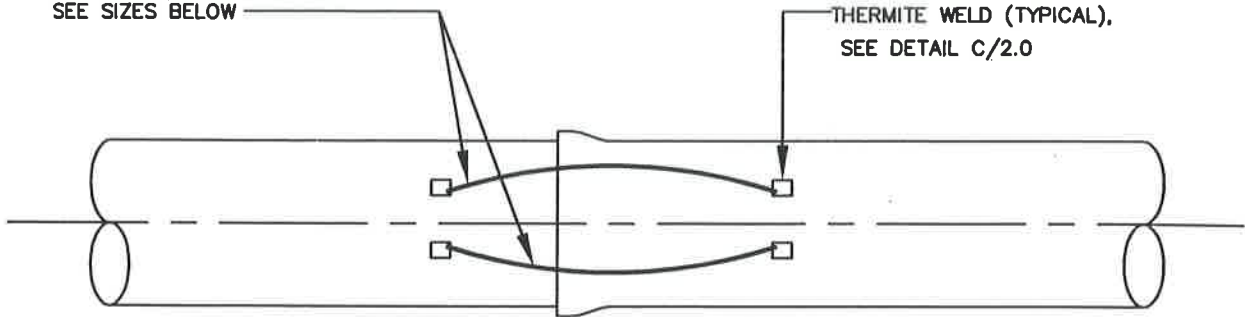

PUSH-ON JOINT

TWO WIRES, MAXIMUM WIRE LENGTH = 24",
 TWO WIRES, MINIMUM WIRE LENGTH = 18",
 SEE SIZES BELOW

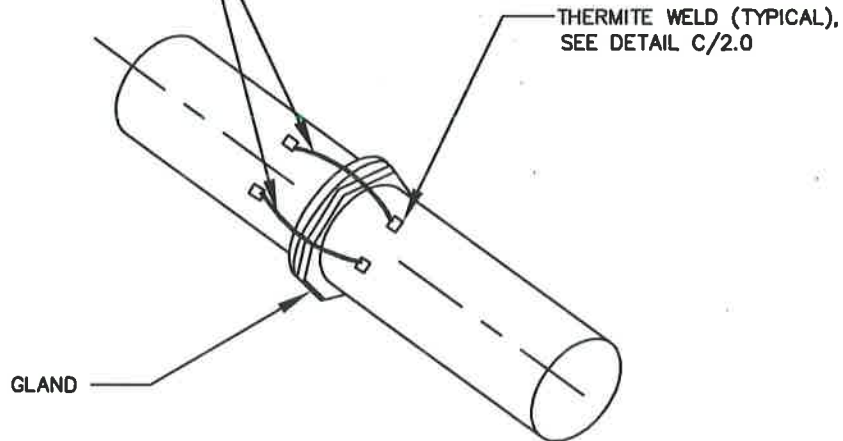

MECHANICAL JOINT

BOND WIRE SIZE	
PIPE DIAMETER	WIRE SIZE
3" THRU 18"	# 4 AWG HMWPE
OVER 18"	# 2 AWG HMWPE

NOTE:

1. THE BOND WIRE SHALL BE STRANDED COPPER WIRE WITH HMWPE INSULATION.

WASHINGTON
 SUBURBAN
 SANITARY
 COMMISSION

APPROVED: 8/12/16

 Chief Engineer

STANDARD DETAIL
 DUCTILE IRON
 PIPE JOINT BOND

C
 1.0