



SECTION V

BLOCKING
DETAILS

SECTION V-BLOCKING DETAILS**TABLE OF CONTENTS**

<u>TITLE</u>	<u>NUMBER</u>
Thrust Blocks for Horizontal Bends	B/1.0
Thrust Blocks for Tees and Tapping Sleeves	B/1.3
Thrust Blocks for Plugs and Caps	B/1.4
Anchorage for 1/32, 1/16 and 1/8 Upper Vertical Bends	B/1.7
Thrust Blocks for 11-1/4 ⁰ , 22-1/2 ⁰ and 45 ⁰ Lower Vertical Bends	B/1.8
Method of Strapping Valve to Main	B/2.0
Method of Restraining Fire Hydrant to Main for 12-inch smaller	B/2.1
Method of Strapping Hydrant to Main for 14-inch larger	B/2.2
Method of Strapping Mechanical Coupling in Vaults and Facilities	B/3.0
Quick Harnessed Connection to Thrust Blocking for Ductile Iron and Cast Iron Pipe	B/3.1
Quick Harnessed Connection to Thrust Blocking for Existing Prestressed Concrete Cylinder Pipe	B/3.1b
Quick Block Direct Thrust	B/3.2
Concrete Thrust Block with Weld-On Thrust Ring on Ductile Iron Pipe	B/3.3



BEND TYPE	PIPE DIAMETER	THRUST BLOCK DIMENSIONS			
		L	H	F	T
1/32	4"	1'-0"	1'-0"	0'-5"	1'-0"
	6"	1'-3"	1'-0"	0'-5"	1'-0"
	8"	1'-6"	1'-3"	0'-5"	1'-0"
	10"	1'-9"	1'-9"	0'-6"	1'-0"
	12"	2'-3"	2'-0"	0'-6"	1'-0"
	14"	3'-0"	2'-0"	0'-6"	1'-0"
	16"	3'-6"	2'-0"	1'-0"	1'-6"
1/16	4"	1'-6"	1'-6"	0'-5"	1'-0"
	6"	1'-9"	1'-6"	0'-5"	1'-0"
	8"	2'-0"	2'-0"	0'-5"	1'-0"
	10"	3'-0"	2'-0"	0'-10"	1'-0"
	12"	4'-0"	2'-0"	0'-10"	1'-6"
	14"	4'-9"	2'-3"	1'-0"	2'-0"
	16"	5'-0"	3'-0"	1'-0"	2'-0"
1/8	4"	1'-6"	1'-6"	0'-6"	1'-0"
	6"	3'-0"	1'-6"	0'-6"	1'-0"
	8"	4'-0"	2'-0"	0'-6"	1'-0"
	10"	5'-0"	2'-6"	0'-10"	2'-6"
	12"	6'-0"	3'-0"	1'-0"	2'-6"
	14"	7'-0"	3'-6"	1'-0"	3'-0"
	16"	8'-0"	4'-0"	1'-0"	3'-6"
1/4	4"	3'-0"	1'-6"	0'-6"	1'-0"
	6"	4'-6"	2'-0"	0'-6"	2'-0"
	8"	6'-0"	2'-6"	0'-6"	2'-6"
	10"	7'-0"	3'-6"	0'-10"	3'-0"
	12"	8'-0"	4'-0"	1'-0"	4'-0"
	14"	9'-0"	5'-0"	1'-0"	4'-0"
	16"	11'-6"	5'-0"	1'-0"	5'-6"

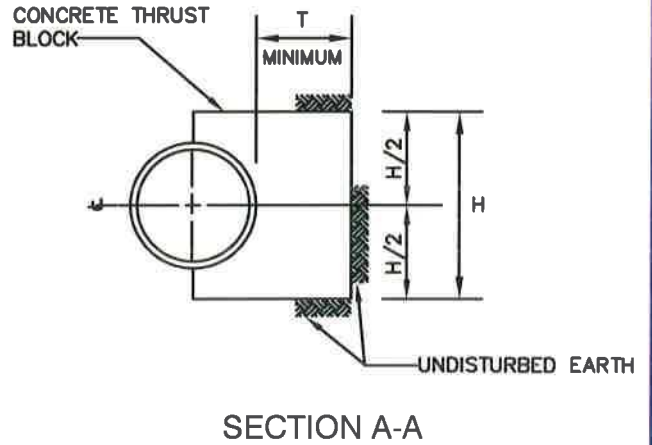
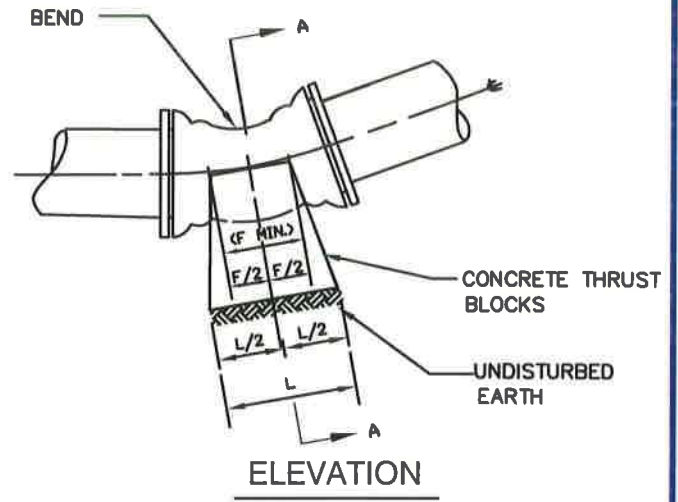

BLOCKING DESIGN REQUIREMENT NOTES

1. CONCRETE STRENGTH $f'_c=3000$ psi AT 28 DAYS.
2. STANDARD THRUST BLOCKING IS BASED ON THE FOLLOWING ASSUMPTIONS AND LIMITATIONS, IF THESE CONDITIONS ARE NOT MET, SPECIAL DESIGN IS REQUIRED:
 - a) TEST PRESSURE (WORKING + SURGE) IS 250 psi OR LOWER.
 - b) DEPTH FROM FINISHED GRADE TO TOP OF PIPE ASSUMED TO EQUAL 4'-0" OR DEEPER.
 - c) ELEVATION OF GROUNDWATER TABLE ASSUMED TO BE BELOW BOTTOM OF THE BLOCK.
3. IF SOIL CONDITIONS ARE SOFT OR ORGANIC, A SPECIAL DESIGN IS REQUIRED AND SHOULD BE SUBMITTED TO TSG FOR REVIEW.
4. FOR LARGER PIPE DIAMETERS, SEE DRAWINGS FOR SPECIAL DETAILS.
5. ALL DIMENSIONS ARE MINIMUMS EXCEPT WHERE LARGER DIMENSION WILL INTERFERE WITH THE PIPE JOINTS OR NOT FACILITATE BOLT REMOVAL ON MECHANICAL JOINT FITTINGS. IN THESE CASES SUBMIT REVISIONS TO TSG.

WASHINGTON
SUBURBAN
SANITARY
COMMISSION

APPROVED: 8/18/16

Chief Engineer

STANDARD DETAIL
THRUST BLOCKS
FOR
HORIZONTAL BENDS

B
1.0

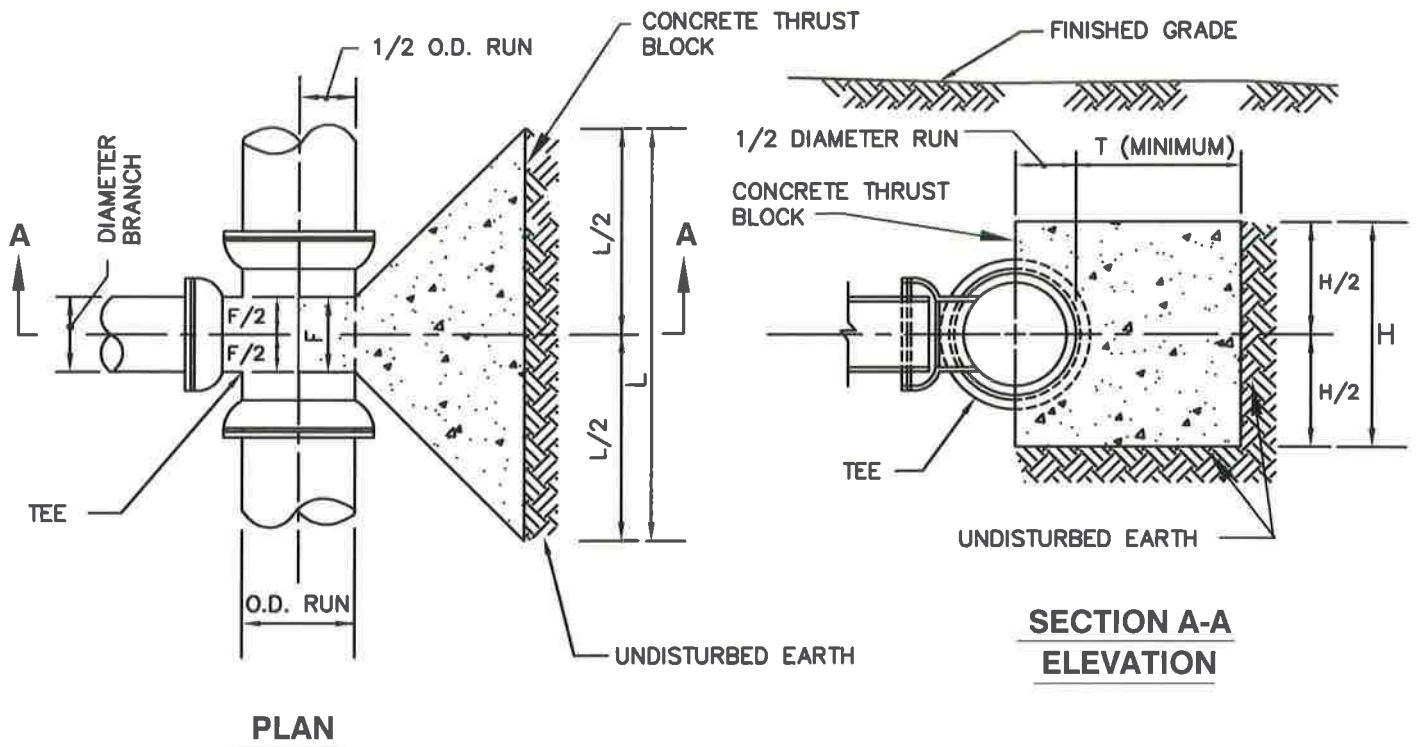

	NOMINAL DIAMETER OF BRANCH						
	4"	6"	8"	10"	12"	14"	16"
L	2'-0"	3'-0"	4'-0"	6'-0"	7'-0"	8'-0"	9'-0"
H	1'-6"	2'-0"	3'-0"	3'-0"	3'-6"	4'-0"	4'-6"
T	1'-0"	1'-0"	1'-6"	2'-6"	3'-0"	3'-6"	4'-0"
F	0'-6"	0'-6"	0'-9"	0'-9"	1'-0"	1'-0"	1'-0"

NOTE:

1. SEE BLOCKING DESIGN REQUIREMENT NOTES, DETAIL B/1.0.

WASHINGTON
SUBURBAN
SANITARY
COMMISSION

APPROVED: 8/18/16

Chief Engineer

STANDARD DETAIL
THRUST BLOCKS FOR
TEES AND TAPPING
SLEEVES

B
1.3

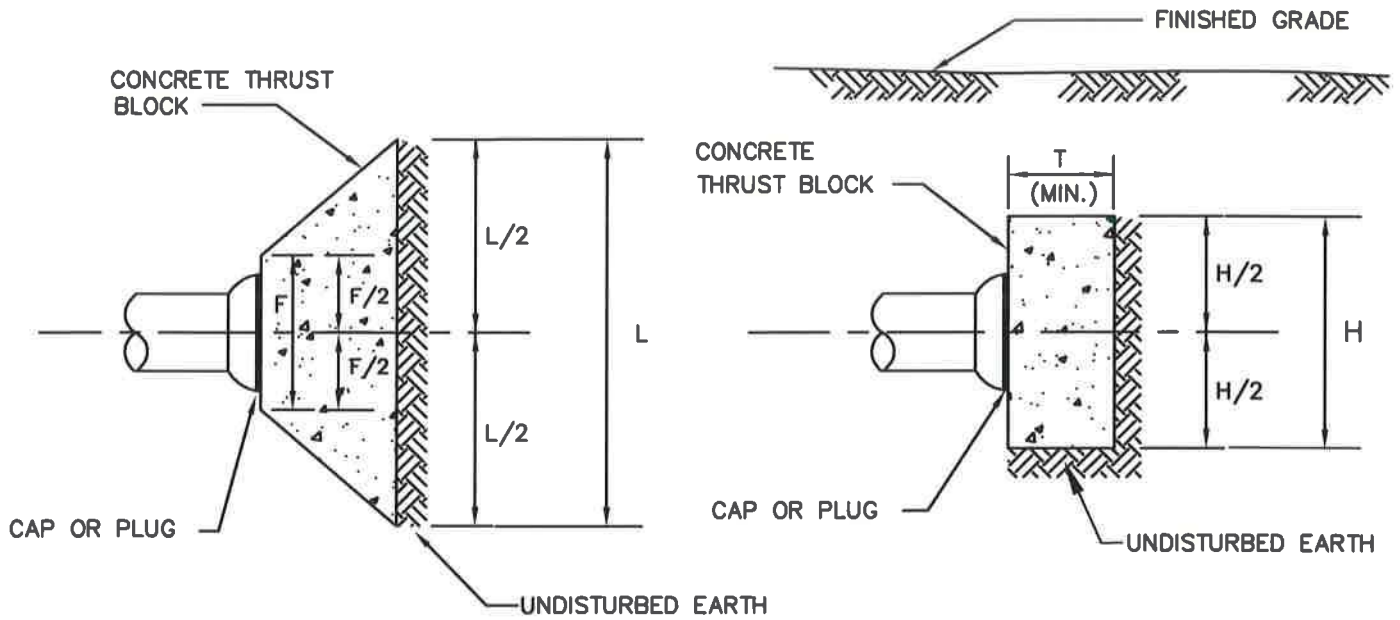

PLAN

ELEVATION

	NOMINAL DIAMETER OF PLUG OR CAP						
	4"	6"	8"	10"	12"	14"	16"
L	2'-0"	3'-0"	4'-0"	6'-0"	7'-0"	8'-0"	9'-0"
H	1'-6"	2'-0"	3'-0"	3'-0"	3'-6"	4'-0"	4'-6"
T	1'-0"	1'-0"	1'-6"	2'-6"	3'-0"	3'-6"	4'-0"
F	1'-0"	1'-0"	1'-0"	1'-0"	1'-6"	1'-6"	2'-0"

NOTE:

1. SEE BLOCKING DESIGN REQUIREMENT NOTES, DETAIL B/1.0.

WASHINGTON
SUBURBAN
SANITARY
COMMISSION

APPROVED: 8/18/16

Chief Engineer

STANDARD DETAIL
THRUST BLOCKS FOR
PLUGS AND CAPS

B
1.4

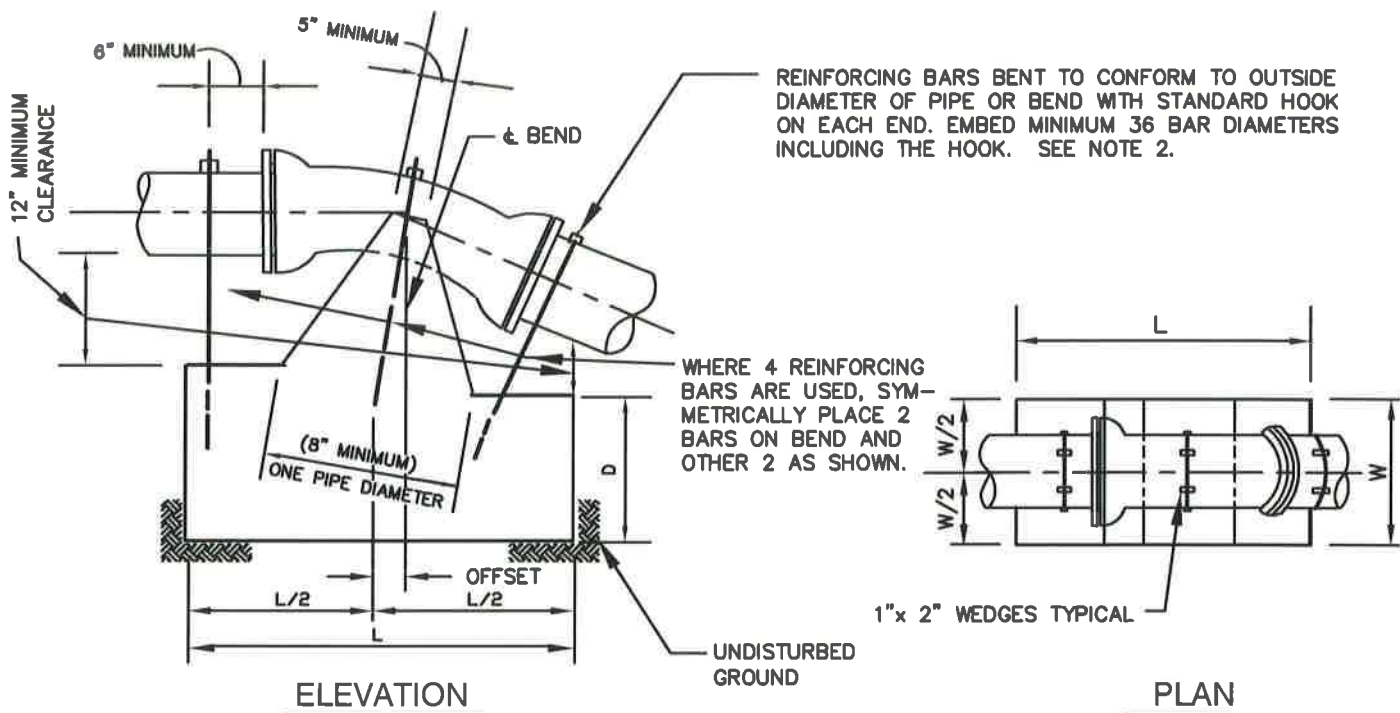

BEND		SIZE						
		4"	6"	8"	10"	12"	14"	16"
1/32	L	1'-9"	2'-6"	3'-0"	3'-0"	3'-6"	4'-3"	5'-0"
	W	1'-9"	2'-3"	2'-9"	3'-3"	3'-9"	4'-3"	5'-0"
	D	1'-9"	2'-0"	2'-6"	3'-0"	3'-3"	3'-3"	3'-3"
	OFFSET	0'-6"	0'-6"	0'-6"	0'-6"	0'-6"	0'-6"	0'-6"
	Rebar	3-#7	3-#7	3-#8	3-#8	3-#8	3-#8	3-#8
1/16	L	2'-6"	3'-0"	3'-6"	4'-0"	5'-0"	5'-6"	6'-3"
	W	2'-3"	3'-0"	3'-6"	4'-0"	4'-6"	5'-3"	6'-0"
	D	2'-0"	2'-6"	3'-3"	3'-9"	4'-0"	4'-0"	4'-0"
	OFFSET	1'-0"	1'-0"	1'-0"	1'-0"	1'-0"	1'-0"	1'-0"
	Rebar	3-#7	3-#7	3-#8	3-#8	4-#8	4-#8	4-#8
1/8	L	3'-0"	3'-9"	4'-9"	5'-6"	6'-6"	6'-9"	7'-6"
	W	2'-9"	3'-6"	4'-0"	5'-0"	6'-0"	6'-0"	7'-0"
	D	2'-6"	3'-3"	4'-0"	4'-0"	4'-0"	5'-3"	5'-3"
	OFFSET	1'-0"	1'-3"	1'-6"	1'-9"	2'-0"	2'-3"	2'-6"
	Rebar	3-#7	3-#7	3-#8	4-#8	4-#8	4-#10	4-#10

- NOTES
- SEE BLOCKING DESIGN REQUIREMENTS NOTES, DETAIL B/1.0.
 - ALL REINFORCING BARS AND WEDGES SHALL BE FACTORY APPLIED ZINC COATING. REPAIR DAMAGE COATING PER MANUFACTURER'S RECOMMENDATIONS.

WASHINGTON SUBURBAN SANITARY COMMISSION	APPROVED: <u>5/18/16</u> Chief Engineer	STANDARD DETAIL ANCHORAGE FOR 1/32, 1/16 AND 1/8 UPPER VERT. BENDS	B 1.7
--	--	---	----------

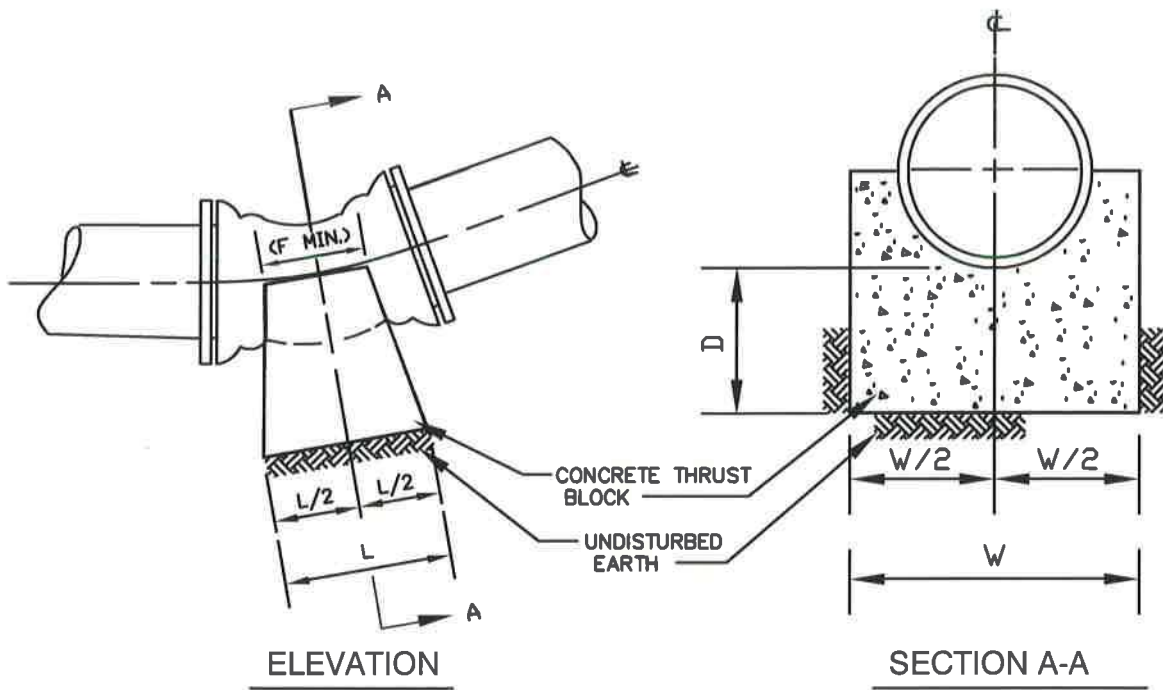

BEND		SIZE						
		4"	6"	8"	10"	12"	14"	16"
1/32	L	0'-6"	1'-0"	1'-6"	1'-9"	2'-0"	2'-3"	3'-0"
	W	1'-0"	1'-0"	1'-6"	1'-6"	2'-0"	2'-3"	2'-3"
	D	0'-9"	0'-9"	0'-9"	0'-9"	0'-9"	1'-0"	1'-0"
	F	0'-5"	0'-5"	0'-5"	0'-5"	0'-6"	0'-6"	0'-6"
1/16	L	1'-0"	1'-6"	2'-0"	2'-6"	2'-9"	3'-6"	4'-0"
	W	1'-0"	1'-6"	2'-0"	2'-6"	2'-9"	3'-0"	3'-3"
	D	0'-9"	0'-9"	0'-9"	1'-0"	1'-0"	1'-6"	1'-6"
	F	0'-5"	0'-5"	0'-5"	0'-6"	0'-6"	0'-6"	0'-6"
1/8	L	1'-6"	2'-0"	2'-9"	3'-6"	4'-0"	4'-0"	5'-0"
	W	1'-6"	2'-0"	2'-6"	3'-6"	3'-9"	5'-0"	5'-0"
	D	0'-9"	0'-9"	1'-0"	1'-6"	1'-6"	2'-0"	2'-0"
	F	0'-5"	0'-5"	0'-5"	0'-6"	0'-6"	0'-6"	0'-6"

NOTE:

1. SEE BLOCKING DESIGN REQUIREMENT NOTES, DETAIL B/1.0.

WASHINGTON
SUBURBAN
SANITARY
COMMISSION

APPROVED: 8/18/16

Chief Engineer

STANDARD DETAIL

THRUST BLOCKS FOR
11 1/4°, 22 1/2°, & 45°
LOWER VERTICAL BENDS

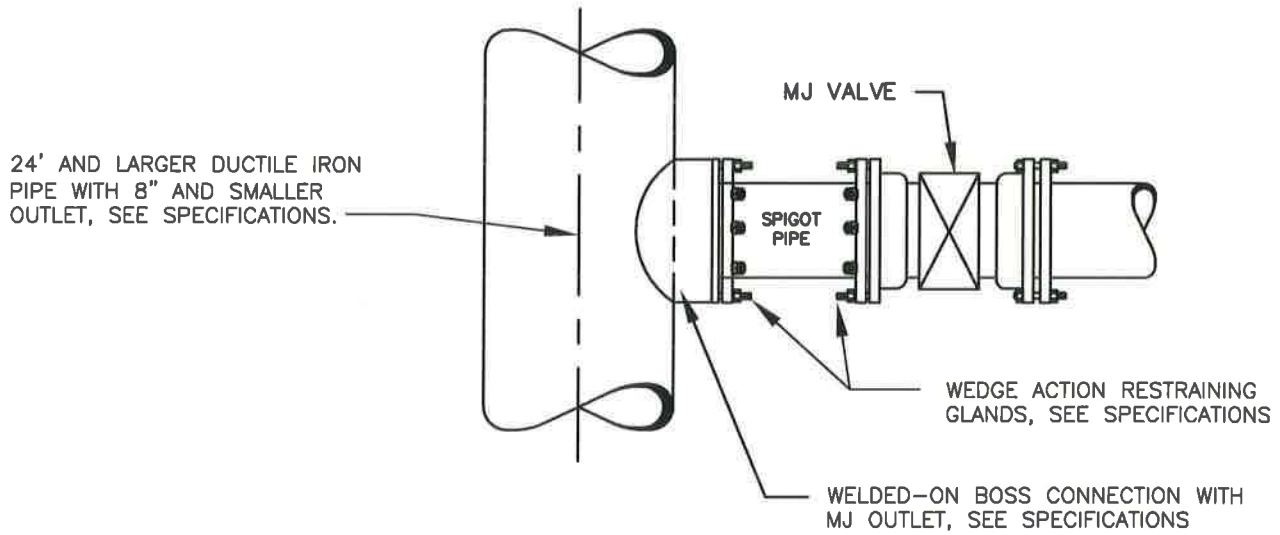
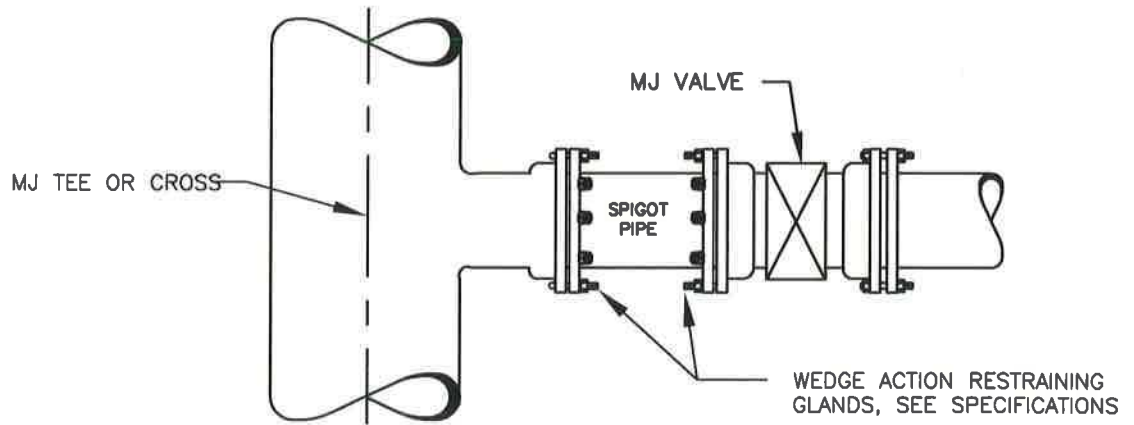
B
1.8



NOTES:

1. USE MECHANICAL JOINT FITTINGS ONLY.

WASHINGTON
SUBURBAN
SANITARY
COMMISSION

APPROVED:

8/12/16

[Signature]
Chief Engineer

STANDARD DETAIL
METHOD OF STRAPPING
VALVE TO MAIN

B
2.0

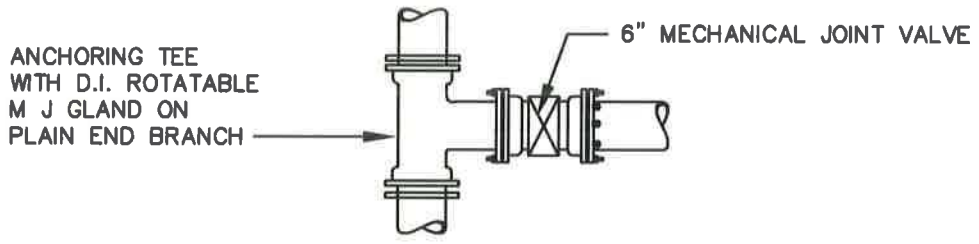

OPTION FOR USE OF ANCHORING COUPLING

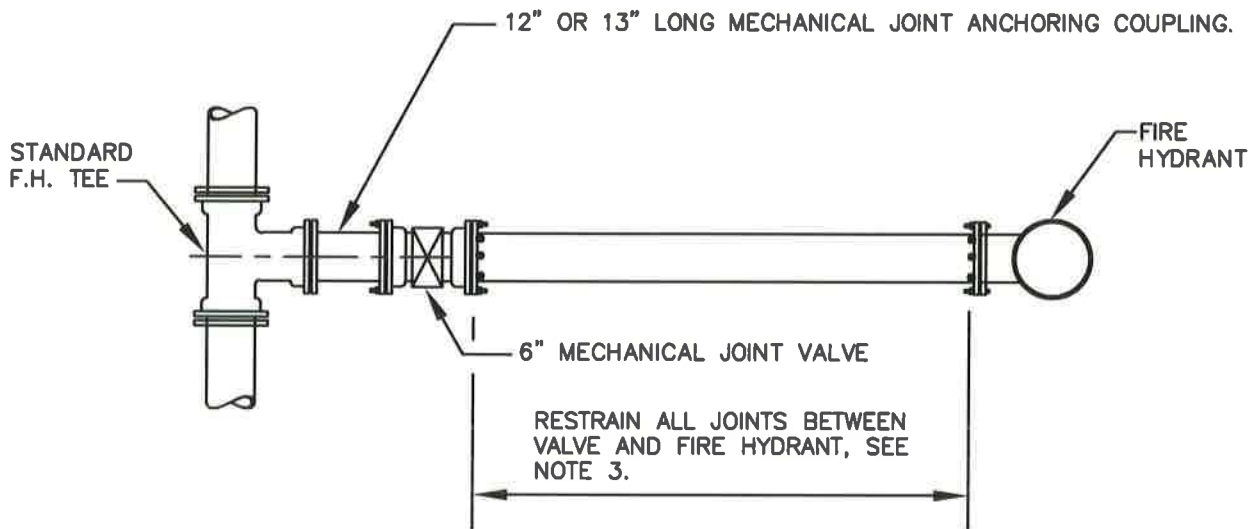

PLAN

NOTES:

1. DO NOT BLOCK FIRE HYDRANT TEE OR FIRE HYDRANT.
2. RESTRAIN ALL JOINTS BETWEEN FIRE HYDRANT TEE AND VALVE, USING ANCHORING TEE OR ANCHORING COUPLING.
3. RESTRAIN ALL JOINTS FROM VALVE TO FIRE HYDRANT, USING WEDGE ACTION RESTRAINING GLANDS OR RESTRAINED JOINT GASKETS, SEE SPECIFICATIONS.
4. PLACE RESTRAINED JOINT PIPE TAPE ON TOP OF PIPE FROM FIRE HYDRANT TEE TO FIRE HYDRANT, SEE SPECIFICATIONS.

WASHINGTON SUBURBAN SANITARY COMMISSION	APPROVED: <u>8/18/16</u>  Chief Engineer	STANDARD DETAIL METHOD OF RESTRAINING FIRE HYDRANT TO MAIN 12-INCH AND SMALLER	<u>B</u> <u>2.1</u>
--	---	---	------------------------

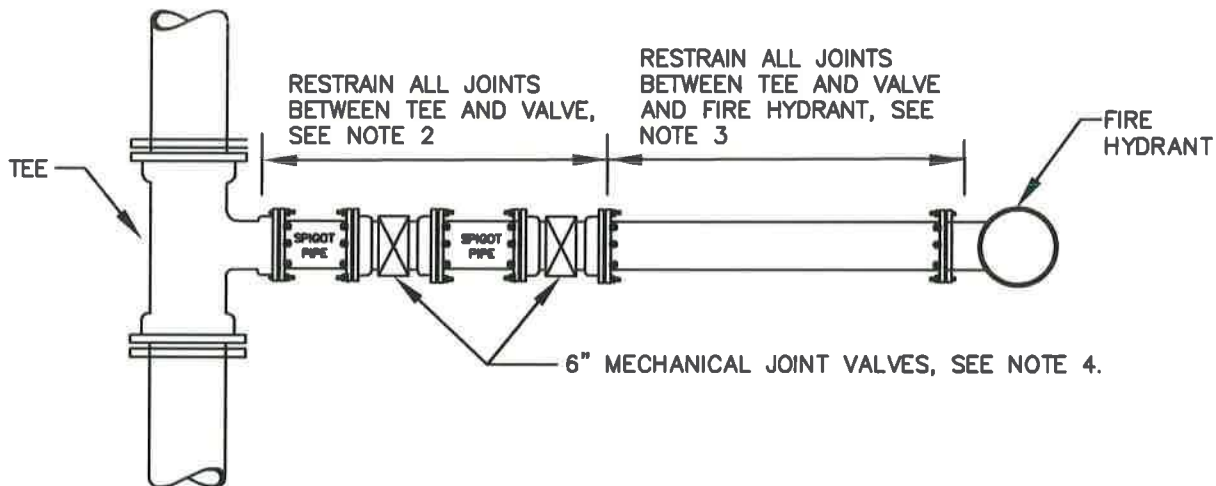

PLAN - 36" AND LARGER MAINS

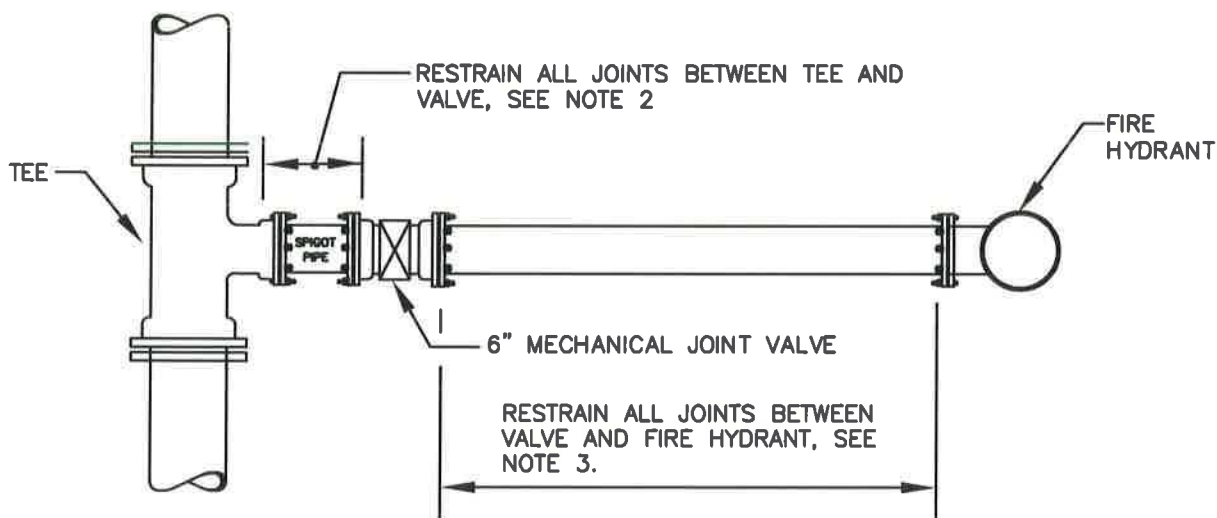

PLAN - 14" TO 30" MAINS

NOTES:

1. DO NOT BLOCK FIRE HYDRANT TEE OR FIRE HYDRANT.
2. RESTRAIN ALL JOINTS BETWEEN FIRE HYDRANT TEE AND VALVE, SEE DETAIL B/2.0
3. RESTRAIN ALL JOINTS FROM VALVE TO FIRE HYDRANT, USING WEDGE ACTION RESTRAINING GLANDS OR RESTRAINED JOINT GASKETS, SEE SPECIFICATIONS.
4. FOR WATER MAINS 36-INCH AND LARGER, USE TWO 6-INCH VALVES.
5. PLACE RESTRAINED JOINT PIPE TAPE ON TOP OF PIPE FROM FIRE HYDRANT TEE TO FIRE HYDRANT, SEE SPECIFICATIONS.

WASHINGTON
SUBURBAN
SANITARY
COMMISSION

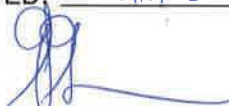
APPROVED: 8/18/16

Chief Engineer

STANDARD DETAIL
METHOD OF RESTRAINING
FIRE HYDRANT TO MAIN
14-INCH AND LARGER

B
2.2

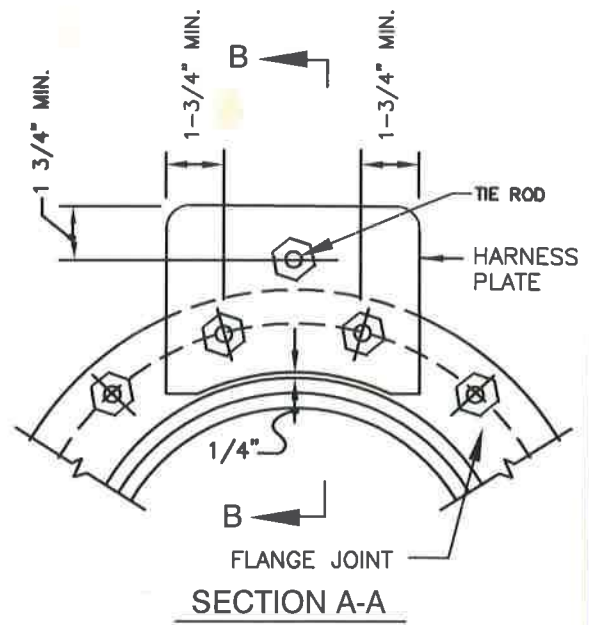
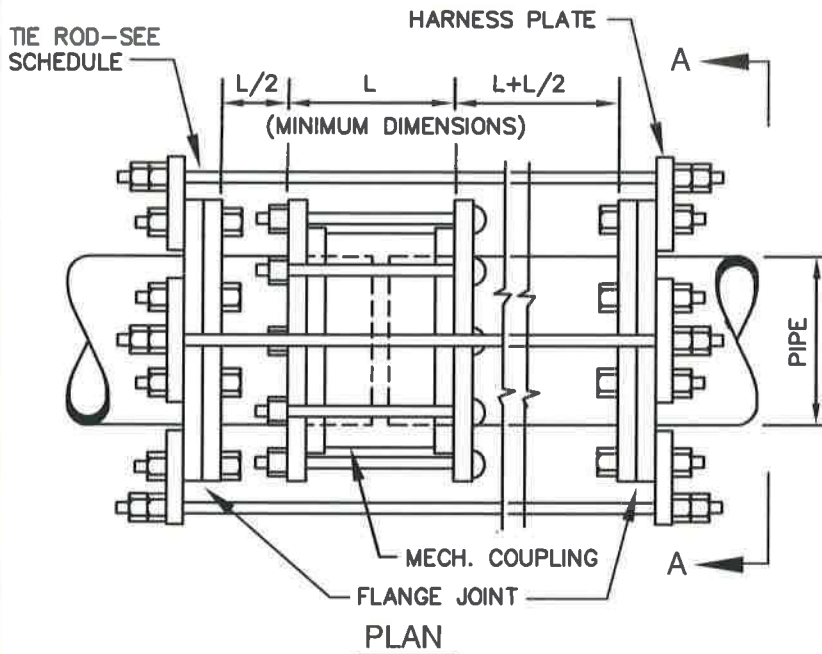

STRAPPING HARNESS DETAIL

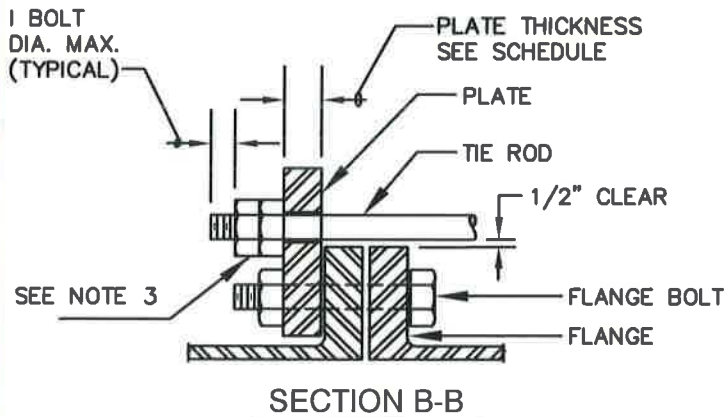

PIPE DIA.	MAXIMUM OPERATING PRESSURE	NO. OF RODS	DIA. OF RODS IN	PLATE THICKNESS
4"	125	2	3/4"	3/4"
	250	2	3/4"	3/4"
6"	125	2	3/4"	3/4"
	250	2	3/4"	3/4"
8"	125	2	7/8"	1"
	250	2	7/8"	1 1/8"
10"	125	2	7/8"	1 1/8"
	250	3	7/8"	1 1/8"
12"	125	3	7/8"	1 1/8"
	250	4	7/8"	1 1/8"
14"	125	4	7/8"	1 1/4"
	250	4	1"	1 1/4"
16"	125	4	1"	1 1/4"
	250	4	1 1/8"	1 1/2"
18"	125	4	1"	1 1/2"
	250	6	1"	1 1/2"
20"	125	4	1"	1 1/2"
	250	6	1 1/8"	1 1/2"
24"	125	6	1"	1 1/2"
	250	6	1 1/8"	1 3/4"
30"	125	7	1 1/8"	1 3/4"
	250	7	1 1/2"	2"

NOTES:

1. SEE DRAWINGS FOR MAXIMUM PIPE THRUST.
2. SEE SPECIFICATIONS FOR APPROVED MANUFACTURER'S OF HARNESS LUGS AND TIE RODS.
3. MINIMUM TIE ROD MATERIAL; STAINLESS STEEL ASTM A193 B8 (304) OR B8M (316).
4. LUG MATERIAL ASTM A240 TYPE 304 OR 316.
5. INSIDE NUT TO BE HAND TIGHTENED, AND TWO NUTS SHALL BE TIGHTENED AGAINST EACH OTHER.
6. STRAPPING DESIGN SHALL INCLUDE SURGE PRESSURE ADDED TO OPERATING PRESSURE.
7. WHEN THE STRAPPING ASSEMBLY IS LOCATED NEAR THE FLANGE VALVE, PROVIDE 12-INCH MINIMUM LENGTH FLANGED BY FLANGED SPOOL PIECE BETWEEN THE VALVE AND ASSEMBLY TO AVOID STRAPPING DIRECTLY TO THE VALVE.

WASHINGTON
SUBURBAN
SANITARY
COMMISSION

APPROVED: 8/12/16

Chief Engineer

STANDARD DETAIL
METHOD OF STRAPPING
MECHANICAL COUPLING
IN VAULTS AND FACILITIES

B
3.0

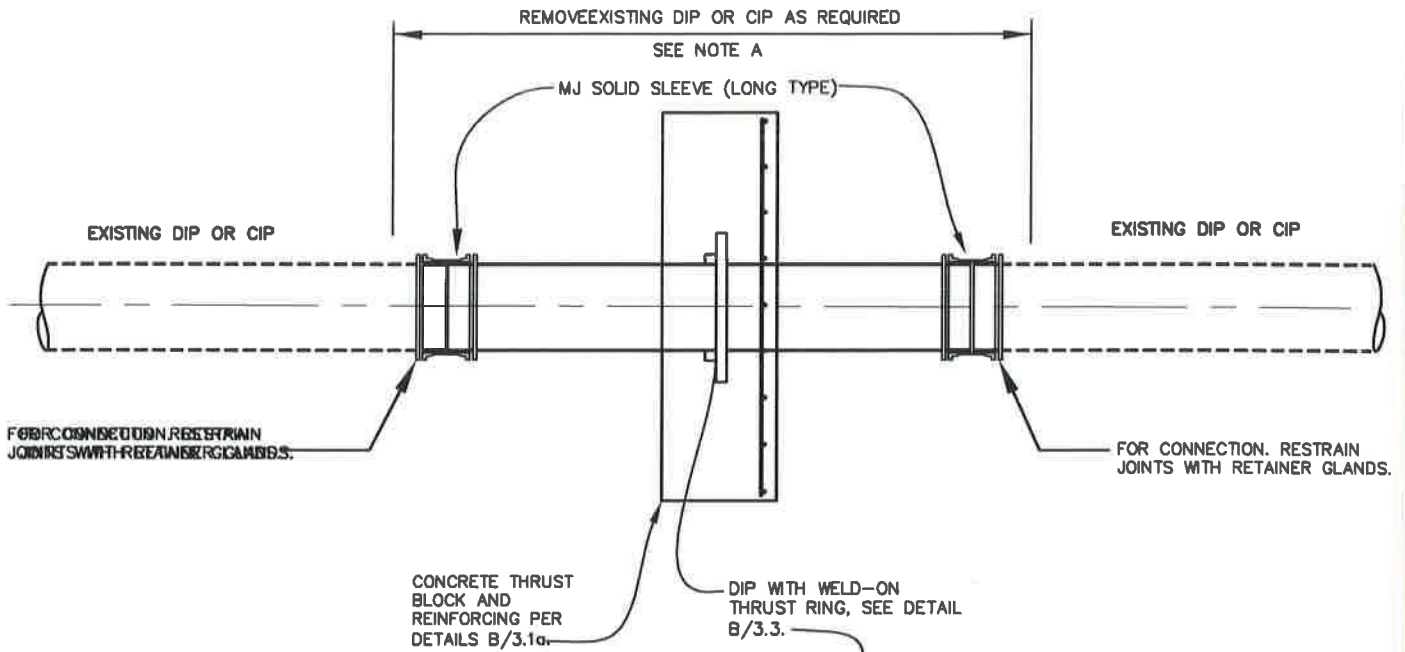

NOTE A:

1. REMOVE MINIMUM TWO SECTIONS OF EXISTING PCCP.
2. INSTALL NEW DIP AND MJ SOLID SLEEVES PLACE EXISTING PIPELINE BACK IN SERVICE.
3. INSTALL CONCRETE THRUST BLOCK AFTER CONNECTION COMPLETED.

PHASE ONE

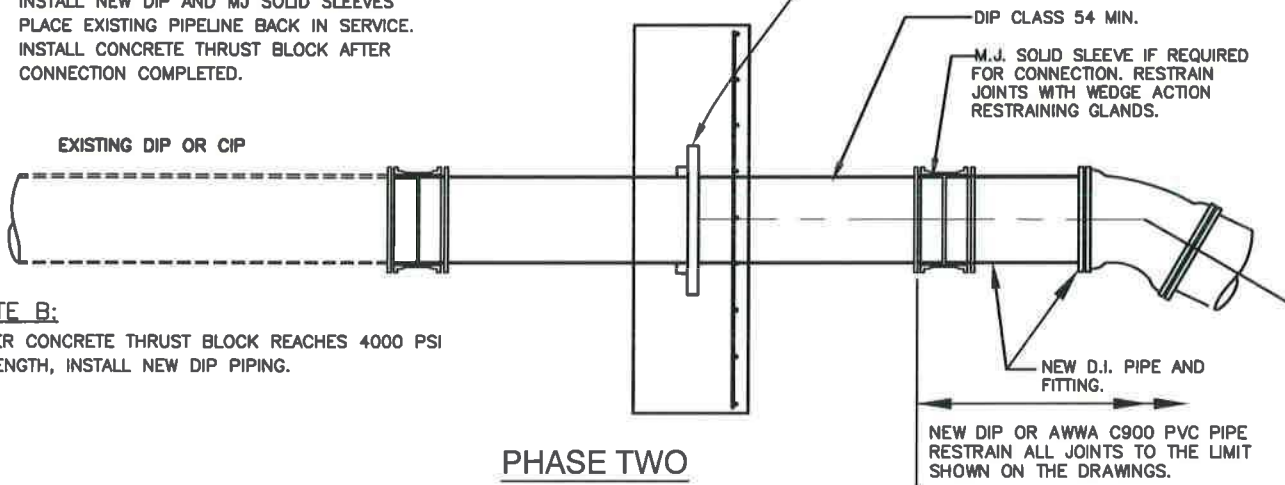

NOTE B:

AFTER CONCRETE THRUST BLOCK REACHES 4000 PSI STRENGTH, INSTALL NEW DIP PIPING.

PHASE TWO

NOTE:

1. SEE DETAIL B/3.3 FOR ADDITIONAL NOTES AND DETAILS..

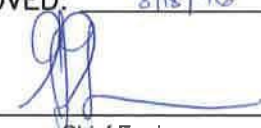
WASHINGTON SUBURBAN SANITARY COMMISSION	APPROVED: <u>8/18/16</u>  Chief Engineer	STANDARD DETAIL QUICK HARNESSSED CONNECTION TO THRUST BLOCKING FOR EXISTING DUCTILE IRON OR CAST IRON PIPE	B <hr/> 3.1
--	---	--	------------------------------

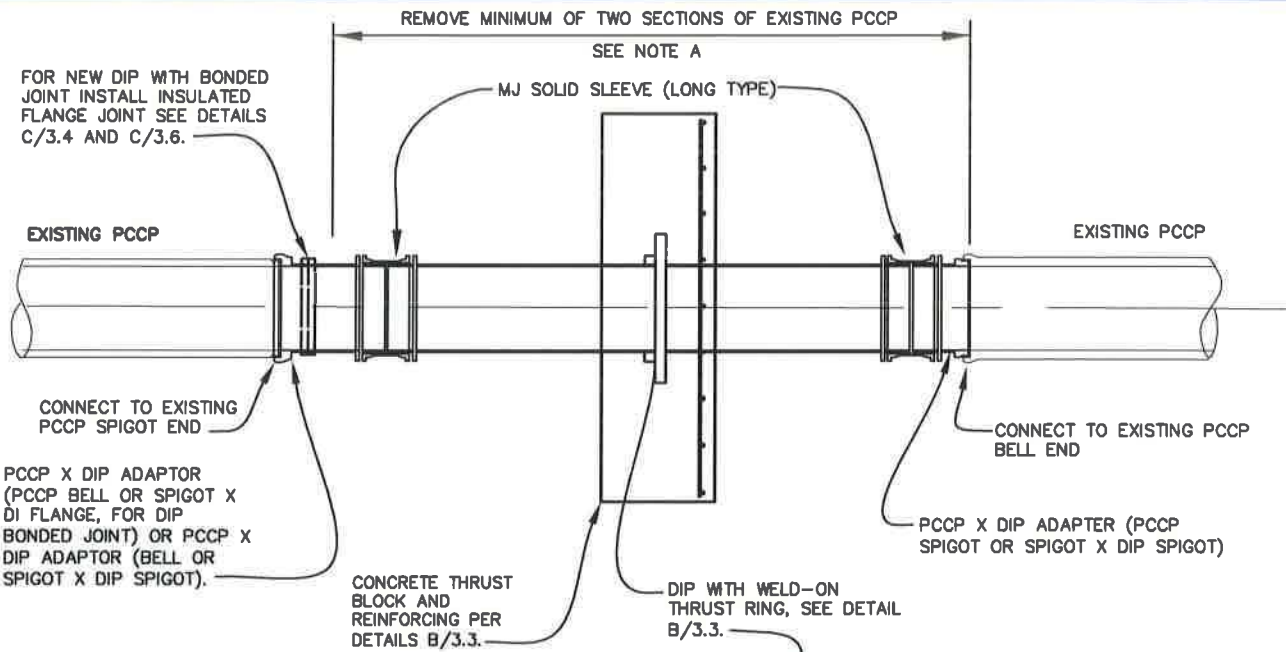

NOTE A:

1. REMOVE MINIMUM TWO SECTIONS OF EXISTING PCCP.
2. INSTALL NEW DIP, MJ SOLID SLEEVES AND PCCP BY DIP ADAPTERS.
3. PLACE EXISTING PIPELINE BACK IN SERVICE.
4. INSTALL CONCRETE THRUST BLOCK AFTER CONNECTION TO PCCP IS COMPLETED.

PHASE ONE

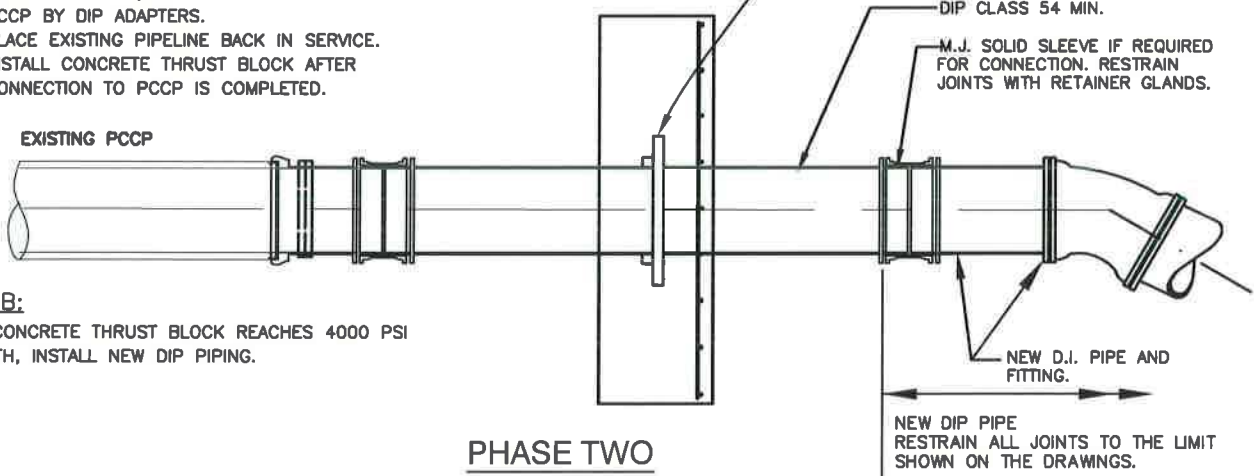

NOTE B:

AFTER CONCRETE THRUST BLOCK REACHES 4000 PSI STRENGTH, INSTALL NEW DIP PIPING.

PHASE TWO

NOTES:

1. SEE DETAIL B.3/3 FOR ADDITIONAL NOTES AND DETAILS
2. FIELD VERIFY EXISTING END CONDITIONS AT CONNECTING POINT AND PROVIDE APPROPRIATE PCCP TO DIP ADAPTER.
3. JOINT BETWEEN PCCP AND DIP x PCCP ADAPTER SHALL BE MORTAR-COATED AFTER ASSEMBLY (FOR NEW DIP BOND PIPE)
4. SEE DETAILS C/3.0, C/3.4 AND C/3.6 FOR INSULATING FLANGE JOINT

WASHINGTON SUBURBAN SANITARY COMMISSION	APPROVED: <u>8/15/16</u>  Chief Engineer	STANDARD DETAIL QUICK HARNESSSED CONNECTION TO THRUST BLOCKING FOR EXISTING PRESTRESSED CONCRETE CYLINDER PIPE	B <hr/> 3.1b
--	---	---	-------------------------------

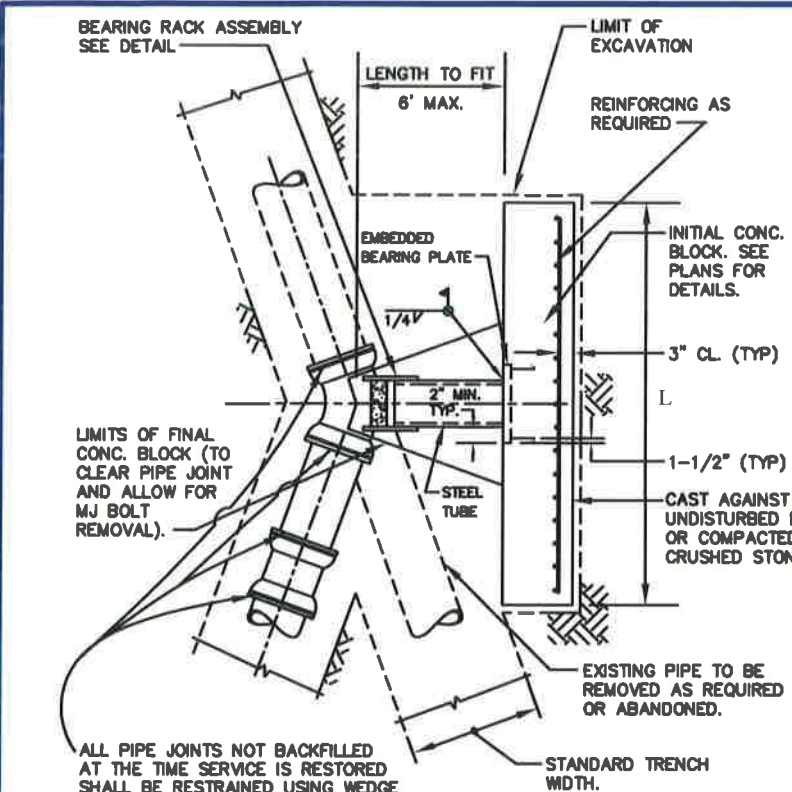

PLAN

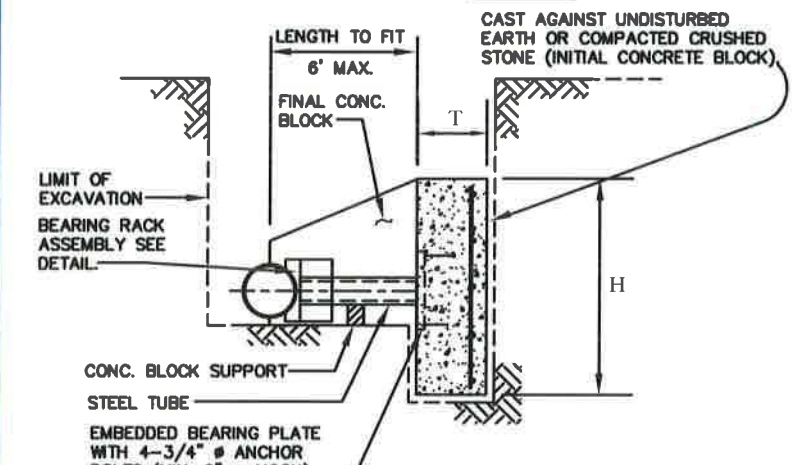

ELEVATION

NOTES:

1. ALL REINFORCING STEEL SHALL CONFORM TO ASTM A-615 GRADE 60.
2. STEEL TUBE SHALL BE ASTM A-500 GRADE B.
3. ALL STEEL PLATE SHALL CONFORM TO ASTM A-36.
4. WELDING SHALL BE 1/4" FILLET WELDS, USING E70XX ELECTRODES UNLESS OTHERWISE SHOWN ON THE DETAILS.
5. IF WORKING PLUS SURGE PRESSURES ARE HIGHER THAN 250 PSI, SPECIAL DESIGN IS REQUIRED AND SHOULD BE SUBMITTED TO TSG FOR REVIEW.
6. FOR 4" THROUGH 16" PIPE, BLOCK DIMENSIONS L AND H SHALL BE AS PER DETAIL B/1.0; T=1'-0"; REINFORCED WITH #5@6" c/c EACH WAY (3 BARS MIN E.W.).
7. SPECIAL DESIGN IS REQUIRED FOR MAINS LARGER THAN 16 INCH AND FOR 90° BENDS. DESIGN SHOULD BE SUBMITTED TO TSG FOR REVIEW.
8. DUCTILE IRON FITTINGS ONLY.

PIPE DIA.	STEEL TUBE	BEARING PLATE
6" THRU 12"	TS 4x4x1/4	16"x16"x1"
16"	TS 8x8x1/4	20"x20"x1"

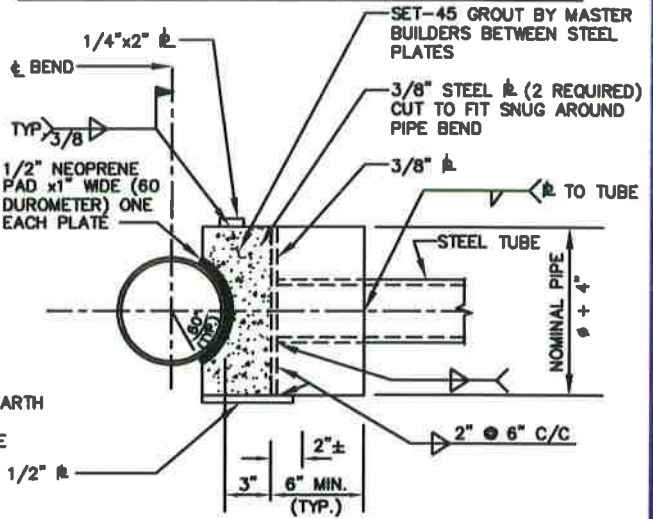

DETAIL - BEARING RACK ASSEMBLY

SEQUENCE OF CONSTRUCTION:

1. EXCAVATE AT LOCATION OF PROPOSED BEND AND BLOCK.
2. CAST INITIAL CONCRETE BLOCK AGAINST UNDISTURBED FACE OF EXCAVATION. CONCRETE SHALL OBTAIN A STRENGTH OF 4000 PSI BEFORE PROCEEDING WITH REMAINDER OF CONSTRUCTION SEQUENCE. TYPE III CEMENT CAN BE USED TO ACHIEVE EARLY REQUIRED STRENGTH.
3. DISCONTINUE SERVICE. INSTALL PROPOSED BEND AND CONNECT NEW WATER MAIN. ABANDON THE EXISTING WATER LINE AS REQUIRED.
4. ADJUST LENGTH OF THE STEEL STRUCTURAL TUBE AND FIELD WELD TO BEARING PLATE EMBEDDED IN INITIAL CONCRETE BLOCK AS SHOWN ON DETAIL. CENTERLINE OF STEEL TUBE SHALL BE ALIGNED WITH BEND CENTERLINE.
5. ATTACH NEOPRENE STRIPS TO BEARING SURFACE OF PIPE BEND.
6. ALIGN BEARING RACK AND POSITION AGAINST PIPE TO PROVIDE FIRM BEARING AGAINST NEOPRENE STRIPS ON PIPE BEND. WELD BEARING RACK ASSEMBLY TO BEAM AS REQUIRED.
7. FILL POCKET BETWEEN PIPE BEND AND BEARING RACK WITH SET-45 GROUT BY MASTER BUILDERS, ALLOW STRENGTH TO REACH $f_c=1000$ PSI PRIOR TO RESTORING SERVICE.
8. BACKFILL ADJACENT PIPES EACH SIDE OF BEND ABOVE SPRING LINE AS MUCH AS PRACTICAL PRIOR TO PRESSURIZATION.
9. RESTORE SERVICE.
10. CAST FINAL CONCRETE BLOCK AFTER TESTING IS COMPLETED. IF POSSIBLE, CAST FINAL BLOCK BEFORE RESTORING SERVICES.
11. BACKFILL EXCAVATION.

WASHINGTON
SUBURBAN
SANITARY
COMMISSION

APPROVED: *8/18/16*

Chief Engineer

STANDARD DETAIL
QUICK BLOCK
DIRECT THRUST

B
3.2

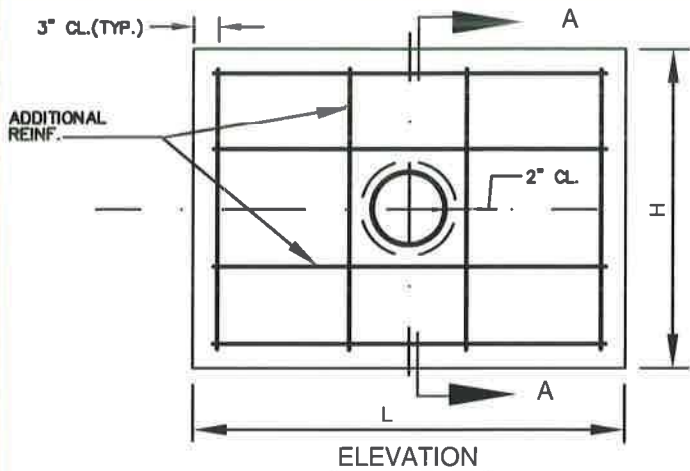

PIPE DIAMETER INCH	THRUST BLOCK DIMENSIONS			THRUST BLOCK REINF.
	T	H	L	
4 AND 6	1'-2"	2'-6"	3'-6"	#5 @ 12" c/c E.W.+4#5 ADD'L REINF.
8	1'-2"	3'-0"	4'-0"	#5 @ 12" c/c E.W.+4#5 ADD'L REINF.
10	1'-4"	4'-0"	4'-0"	#5 @ 12" c/c E.W.+4#5 ADD'L REINF.
12	1'-4"	5'-0"	5'-0"	#5 @ 12" c/c E.W.+4#5 ADD'L REINF.
14	1'-4"	6'-0"	6'-0"	#5 @ 10" c/c E.W.+4#5 ADD'L REINF.
16	1'-6"	6'-0"	8'-0"	#5 @ 8" c/c E.W.+4#5 ADD'L REINF.
18	1'-6"	6'-0"	11'-0"	#5 @ 6" c/c E.W.+4#5 ADD'L REINF.

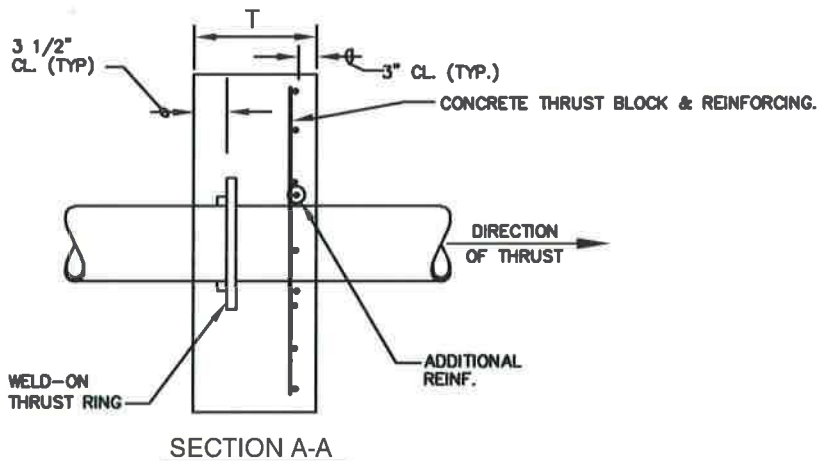

NOTES:

1. ALL CONCRETE SHALL BE $f'_c=4000$ PSI @ 28 DAYS. PIPELINE SHALL NOT BE PRESSURIZED UNTIL CONCRETE STRENGTH REACHES 4000 PSI. AND TRENCH HAS BEEN BACKFILLED.
2. ALL REBARS SHALL BE ASTM A615 GRADE 60.
3. DUCTILE IRON PIPE ONLY.
4. MAINTAIN 2" CLEAR BETWEEN ALL REBARS AND PIPE.
5. WELD-ON THRUST RINGS AND PIPE TO WHICH THEY ARE ATTACHED SHALL BE DESIGNED BY THE PIPE MANUFACTURER FOR THRUST EQUIVALENT TO THE WATER MAIN PRESSURE OF 250 PSI MIN. THE AREA OF THE RING SHALL BE PROPORTIONED SUCH THAT THE BEARING STRESS ON THE CONCRETE DOES NOT EXCEED 1000 PSI.
6. THRUST RING SHALL BE LOCATED 2'-6" MINIMUM FROM END OF PIPE.
7. A SPECIAL DESIGN IS REQUIRED AND SHOULD BE SUBMITTED TO TSG FOR REVIEW:
 - a. IN CASES WHEN THRUST FORCE CAN ACT IN EITHER DIRECTION. ONLY A WELD-ON THRUST RING DESIGNED FOR BI-DIRECTIONAL THRUST SHALL BE USED AND IT SHALL BE PLACED AT THE 1/2 'T' DIMENSION OF THE CONCRETE THRUST BLOCK.
 - b. IF WORKING PLUS SURGE PRESSURES ARE HIGHER THAN 250 PSI.
 - c. FOR MAINS LARGER THAN 18 INCH.
 - d. IF DEPTH FROM FINISHED GRADE TO TOP OF PIPE IS SHALLOWER THAN 4'-0".
 - e. IF GROUNDWATER IS ABOVE BOTTOM OF BLOCK.
 - f. IF SOFT OR ORGANIC SOIL CONDITIONS EXIST.
8. REPLACE ALL DISTURBED SOIL ON THE THRUST SIDE OF THE BLOCK WITH CRUSHED STONE COMPACTED AS STRUCTURAL FILL.

WASHINGTON
SUBURBAN
SANITARY
COMMISSION

APPROVED: 8/12/16

Chief Engineer

STANDARD DETAIL
CONCRETE THRUST BLOCK
WITH WELD-ON THRUST RING
ON DUCTILE IRON PIPE

B
3.3