

TYPE OF HYDRANT	H (IN.)	
	MIN.	MAX.
U.S. PIPE AND FOUNDRY CO.	18	24
MUELLER COMPANY	18	24
KENNEDY VALVE	17 1/4	23 1/4
AMERICAN FLOW CONTROL	14	20

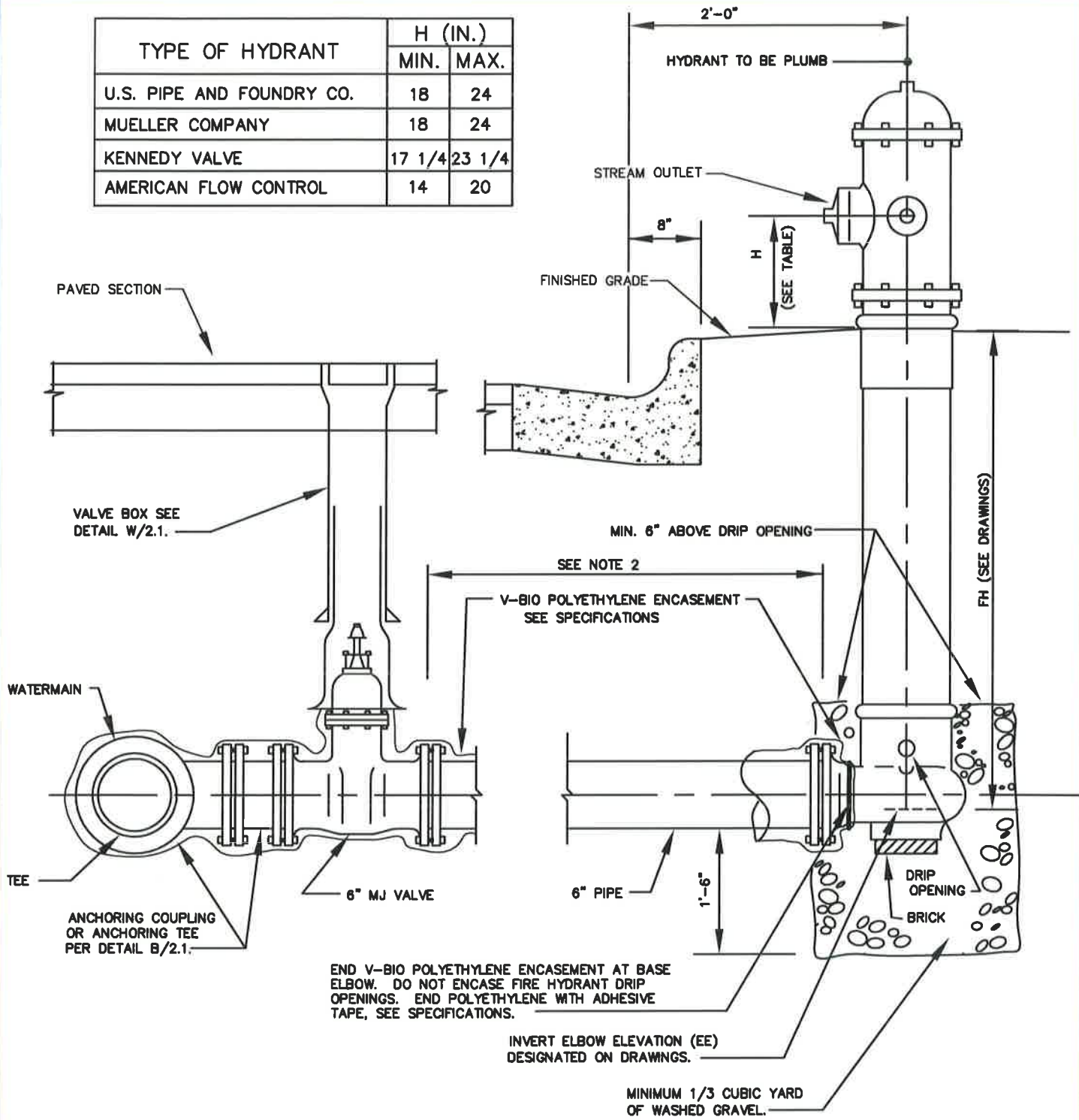

**NOTES:**

1. DO NOT BLOCK FIRE HYDRANT OR FIRE HYDRANT TEE.
2. FOR RESTRAINING VALVE TO FIRE HYDRANT, SEE DETAIL B/2.1.

WASHINGTON  
SUBURBAN  
SANITARY  
COMMISSION

APPROVED: 9/28/16  
  
Chief Engineer

STANDARD DETAIL  
**FIRE HYDRANT SETTING  
CLOSED PAVING SECTION**

W  
8.0