



## Backflow and Hose Bibb Tags Meter Wire & Fire Hydrant Meter Rentals

WSSC Water has three available options for obtaining testable assembly backflow tags, non-testable device backflow tags, and hose bibb winterization tags. For meter wire, see Option #1 below.

### **Option #1 of 3:**

**Warehouse pickup - WSSC Water printed backflow or hose bibb tags and/or meter wire (Pick-up By Scheduled Appointment Only – Please be sure to contact the Warehouse and schedule an Appointment before traveling to or arriving at any WSSC Water Warehouse):**

### **Scheduling and Planning the Tag or Meter Wire Pick Up:**

An appointment is required and usually requires a 24-hour advance notice. Scheduling an appointment is possible through email or by calling a WSSC Water Warehouse.

- **Email** - meterwiretags@wsscwater.com
- **Warehouse Phone Numbers:**
  - Anacostia - 301-206-4273
  - Temple Hills - 301-206-7318
  - Lyttonsville - 301-206-7929
  - Gaithersburg 301-206-7366
- **Provide the following when scheduling your appointment:**
  - Requested pick up date
  - Principal Master Plumber name, registration number, & Company name
  - Name of the individual that will be picking up the tags or meter wire. Note: If the Master Plumber is not personally picking up the tags or meter wire, a Master Plumber can designate up to six representatives to act on his/her behalf by emailing a formal letter on company letterhead to meterwiretags@wsscwater.com. Designated representatives are permitted to pick up tags or meter wire with a valid driver's license, copy of the Certificate of Registration, & copy of the formal letter.
  - Tag type (testable, non-testable, or hose bibb winterization) and quantity requested (There are 50 tags per pack), or meter wire spool quantity requested. Note: Per pick up, the Anacostia Warehouse allows a maximum of 10 tag packs and/or 10 wire spools while the other 3 warehouses allow a maximum of 3 tag packs and/or 3 wire spools.
  - If emailing your request - Attach a copy of the Master Plumber's Certificate of Registration card to the email or be prepared to present the card (or a copy of the card if you are a designated representative) when arriving for your warehouse appointment to obtain the tags and/or meter wire.

**PLEASE SEE NEXT PAGE FOR WAREHOUSE PICKUP INSTRUCTIONS AND OPTION #2 AND OPTION #3**



## Backflow and Hose Bibb Tags Meter Wire & Fire Hydrant Meter Rentals – Page 2

### **PICKING UP YOUR ORDER AT THE WAREHOUSE:**

- 1.) **Call** the applicable Warehouse prior to arriving for your scheduled appointment.
- 2.) Present your Driver's License
- 3.) Present either your Master Plumber Certificate of Registration or a copy of the Master Plumber's Certificate of Registration.
- 4.) If the Principal Master is not personally picking up the tags or meter wire, a copy of the Principal Master Plumber's authorization letter must be presented, the letter must include the name of the individual that is picking up the tags or meter wire, and the Master Plumber Certificate of Registration copy must be presented to the Warehouse staff.

### **FIRE HYDRANT METER RENTALS – By Scheduled Appointment Only:**

Detailed instructions for rental of a large or small diameter fire hydrant meter are provided on the WSSC Water web page - [Fire Hydrants: Maintenance and Meter Rentals | WSSC Water](#). Fire hydrant meters can be rented through the Temple Hills, Lyttonsville, or Gaithersburg Warehouses (see page 1 for phone numbers). The fire hydrant meters can also be rented by contacting the Hyattsville Utility Services Building at (301)-206-4264 and press option #6.

### **Option #2 of 3:**

**Print PDF fillable versions of WSSC Water backflow or hose bibb tags as provided in this document.**

- First** Select the preferred tag from the options provided on the following pages.  
Page 3 – testable assembly fillable tag  
Page 4 – non-testable device fillable tag  
Page 5 – hose bibb maintenance winterization tag
- Second** Complete the fillable fields in your selected document
- Third** Print the completed tag selecting the proper page in your printer settings
- Fourth** Attach the completed document/tag to the assembly, device, or hose bibb shut off valve
- Note:** The printed document is not a WSSC Water printed tag. However, when printed, properly completed, and attached to the non-testable device or testable assembly, the printed document conforms to WSSC tag requirements.

**Recommended:** Enter information into the fillable tags where possible, then print the tags before taking to the field. Place the printed tag(s) in a zip type bag or laminate, then attach to the non-testable device or testable assembly.

### **Option #3 of 3:**

**The licensed plumber may, at their expense, use a custom printed (company branded, weather resistant, or other) tag:**

At their expense, plumbers may utilize their own testable assembly backflow tags, non-testable device backflow tags, and hose bibb winterization tags if the information contained on the company provided tag displays, at a minimum, the same information as provided on the WSSC Water tag.

WSSC Water Code Section 302.3.7 requires that a dated test tag indicating the corresponding Test Report number and test results shall be attached to each testable backflow assembly.  
 Once all information is entered, print and attach this document to the backflow assembly.  
**RECOMMENDED – PLACE IN ZIP TYPE BAG OR LAMINATE**



## BACKFLOW PREVENTION INSPECTION TAG

### CERTIFICATION OF BACKFLOW TEST

Permit No. \_\_\_\_\_

BACKFLOW TEST DATE \_\_\_\_\_

WSSC Water Master Plumber \_\_\_\_\_ ID# \_\_\_\_\_

Bldg. Address \_\_\_\_\_

Test Report No. \_\_\_\_\_

The Washington Suburban Sanitary Commission's Plumbing and Fuel Gas Code require that the backflow preventer be tested a minimum of every 12 months and rebuilt as needed.

This document was printed and completed by the Plumbing Contractor and is not a WSSC Water issued testable assembly tag. However, when properly completed, printed, and attached, this document will conform to WSSC Water testable assembly tag standards.

## BACKFLOW DEVICE TEST REPORT

SERIAL NO. _____			
	Check Valve No. 1	Check Valve No. 2	Differential Pressure Relief Valve
Initial Test	1. Leaked..... <input type="checkbox"/> 2. Closed Tight..... <input type="checkbox"/>	1. Leaked..... <input type="checkbox"/> 2. Closed Tight..... <input type="checkbox"/>	1. Opened at .....lbs. reduced pressure 2. Did not open..... <input type="checkbox"/>
R E P A I R S			
Final Test	2. Closed Tight..... <input type="checkbox"/>	2. Closed Tight..... <input type="checkbox"/>	1. Opened at .....lbs. reduced pressure

TESTED BY: \_\_\_\_\_ WSSC WATER ID # \_\_\_\_\_



# BACKFLOW TAG FOR ASSE 1012, ASSE 1022 ASSE 1024 DEVICES

## WASHINGTON SUBURBAN SANITARY COMMISSION

This document was printed by the Plumber, Installer, Owner, or other entity and is not a WSSC Water issued non-testable device tag. However, when properly completed, printed, and attached, this document will conform to WSSC Water non-testable device tag standards.

**NOTE: OWNER'S RESPONSIBILITY**  
(IT MAY BE NON-POTABLE WATER BEYOND THIS DEVICE)  
"FOR OPTIMUM PERFORMANCE AND SAFETY, WSSC  
CODE REQUIRES THAT THIS DEVICE SHALL BE  
REPLACED OR REBUILT EVERY FIVE (5) YEARS."

Installation Date: \_\_\_\_\_

Replace or Rebuild by: \_\_\_\_\_

Replacement shall be performed by a WSSC Water Registered  
Plumber, or by the Homeowner where applicable. (permit not required)



# BACKFLOW TAG FOR ASSE 1012, ASSE 1022 ASSE 1024 DEVICES

## WASHINGTON SUBURBAN SANITARY COMMISSION

This document was printed by the Plumber, Installer, Owner, or other entity and is not a WSSC Water issued non-testable device tag. However, when properly completed, printed, and attached, this document will conform to WSSC Water non-testable device tag standards.

**NOTE: OWNER'S RESPONSIBILITY**  
(IT MAY BE NON-POTABLE WATER BEYOND THIS DEVICE)  
"FOR OPTIMUM PERFORMANCE AND SAFETY, WSSC  
CODE REQUIRES THAT THIS DEVICE SHALL BE  
REPLACED OR REBUILT EVERY FIVE (5) YEARS."

Installation Date: \_\_\_\_\_

Replace or Rebuild by: \_\_\_\_\_

Replacement shall be performed by a WSSC Water Registered  
Plumber, or by the Homeowner where applicable. (permit not required)

# HOSE BIBB MAINTENANCE COLD WEATHER

(NOV. 1 – APR. 1)

1. CLOSE Valve Inside
2. REMOVE Garden Hose
3. OPEN Hose Bibb (Leave Open)
4. DRAIN Vacuum Breaker  
(Location & operation vary with Mfg.)
5. OPEN Bleed Orifice at Inside Valve

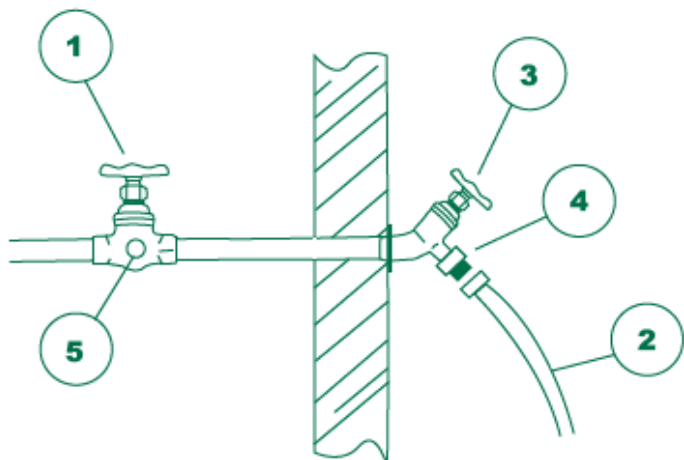

This document was printed by the Plumber, Installer, Owner, or other entity and is not a WSSC issued Hose Bibb Maintenance tag. However, when printed and attached to the hose bibb shut off valve, this document will conform to WSSC Water tag standards.

# HOSE BIBB MAINTENANCE WARM WEATHER

(APR. 1 - NOV. 1)

5. CLOSE Bleed Orifice at Inside Valve
4. RESET Vacuum Breaker  
(Location and operation vary with Mfg.)
3. CLOSE Hose Bibb
2. ATTACH Garden Hose
1. OPEN Valve Inside

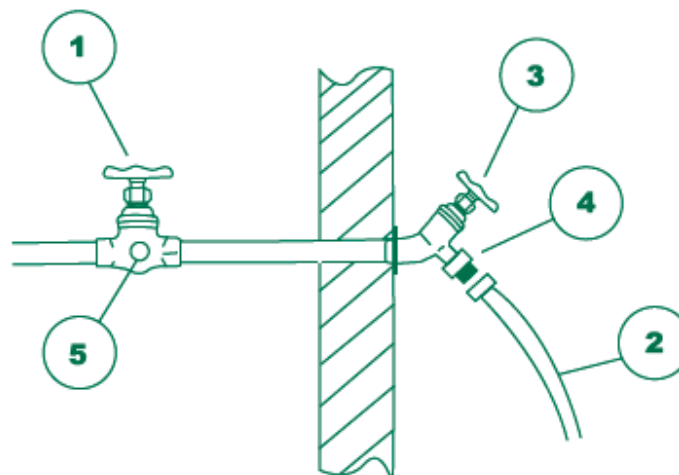

This document was printed by the Plumber, Installer, Owner, or other entity and is not a WSSC issued Hose Bibb Maintenance tag. However, when printed and attached to the hose bibb shut off valve, this document will conform to WSSC Water tag standards.