

COMMISSION MEETING

May 17, 2017

Engineering and Construction Team

2017 PIPELINE DESIGN MANUAL

Item Number:

Table of Contents

1.	Commission Summary	P.1
2.	Resolution	P 2-3
3.	Overview and Public Comment Chronology	P 4-5
4.	Summary of Changes	P 6-8
5.	WSSC 2017 Pipeline Design Manual	P 9-513

Total Number of Pages 513 (without this cover sheet)



# WASHINGTON SUBURBAN SANITARY COMMISSION

## COMMISSION SUMMARY

**AGENDA CATEGORY:** Engineering and Construction Team

**ITEM NUMBER:** 2016-2153

**DATE:** May 17, 2017

<b>SUBJECT</b>	2017 Pipeline Design Manual
<b>SUMMARY</b>	<p>WSSC Staff requests the approval and adoption of the 2017 WSSC Design Manual Update. The update will effectively address several important subjects including: Variances; requirements for Zinc Coated Ductile Iron; looping water systems; Survey and Easement Criteria; Subsurface Investigations; low pressure sewers; service connections; and the relocation and/or rehabilitation of WSSC mains.</p>
<b>SPECIAL COMMENTS</b>	<p>WSSC staff presented the proposed update governmental and industry stakeholders. Reviewers included Prince George's County Government and the Maryland Building Industry Association. A table displaying the Public Comment Chronology is attached.</p>
<b>CONTRACT NO. / REFERENCE NO.</b>	N/A
<b>COSTS</b>	<p>There is minimal financial impact to property owners. None of the proposed update changes requires an increase in existing fees or creation of new fees.</p>
<b>AMENDMENT/ CHANGE ORDER NO.</b>	N/A
<b>MBE PARTICIPATION</b>	N/A
<b>PRIOR STAFF/ COMMITTEE REVIEW</b>	Chief Engineer, ELT General Manager/CEO
<b>RECOMMENDATION TO COMMISSION</b>	APPROVE
<b>COMMISSION ACTION</b>	N/A

**WASHINGTON SUBURBAN SANITARY COMMISSION**

**RESOLUTION 2017-2153**

**ADOPTION OF A NEW WSSC 2017 PIPELINE DESIGN MANUAL  
TO REPLACE EXISTING WSSC PIPELINE DESIGN MANUAL**

WHEREAS, the Washington Suburban Sanitary Commission (“Commission”) is an agency of the State of Maryland with a mission to provide safe and reliable water in a cost-effective and sustainable manner to 1.8 million customers in Montgomery and Prince George’s Counties; and

WHEREAS, the Commission is authorized by the Maryland Annotated Code, Public Utility Article, Division II, §17-403, to adopt rules and regulations to carry out the provisions of Division II of the Public Utility Article and any other laws, the administration and enforcement of which are vested in the Commission; and

WHEREAS, in March 2008, the Commission found it appropriate to organize and consolidate certain standards and criteria pertaining to the planning, design and construction of water and sewer systems, into a comprehensive pipeline design manual, and adopted the 2008 WSSC Pipeline Design Manual (“Pipeline Design Manual”); and

WHEREAS, the Commission periodically reviews and adopts updates to the Pipeline Design Manual, including an update in March 2015; and

WHEREAS, the Commission desires to once again update the Pipeline Design Manual and do so through the adoption of a new 2017 WSSC Pipeline Design Manual as a regulation, to replace the Pipeline Design Manual;

NOW, THEREFORE, BE IT RESOLVED, this \_\_\_\_\_ day of \_\_\_\_\_, 2017, that:

- 1) The Commission hereby adopts the Washington Suburban Sanitary Commission 2017 Pipeline Design Manual as a regulation to replace the existing March 2015 Pipeline Design Manual;
- 2) The Washington Suburban Sanitary Commission 2017 Pipeline Design Manual shall become effective as a regulation in accordance with the requirements of Section 17-403 of the Public Utilities Article, Md. Code Ann.; and
- 3) The existing March 2015 WSSC Pipeline Design Manual shall be considered replaced on, and as of, the date the 2017 Pipeline Design Manual becomes effective.

BE IT FURTHER RESOLVED, that if any section, subsection, sentence, clause, or phrase of this Resolution 2017-\_\_\_\_ is, for any reason, held to be unlawful, such decision shall not affect the validity of the remaining portions of this Resolution.

A True Copy.

Attest:

---

Sheila R. Finlayson, Esq.  
Corporate Secretary  
Washington Suburban Sanitary Commission

## OVERVIEW OF THE 2017 WSSC DESIGN MANUAL UPDATE

*AGENDA CATEGORY: Engineering and Construction Team*

*ITEM NUMBER:*

*DATE: April 19, 2017*

### **Overview**

WSSC Staff requests the approval and adoption of the 2017 WSSC Design Manual Update. The update will effectively address several important subjects including: Variances; requirements for Zinc Coated Ductile Iron; looping water systems; Survey and Easement Criteria; Subsurface Investigations; low pressure sewers; service connections; and the relocation and/or rehabilitation of WSSC mains.

WSSC staff presented the proposed update governmental and industry stakeholders. Reviewers included Prince George's County Government and the Maryland Building Industry Association. A table displaying the Public Comment Chronology is attached. Several minor comments were received and they were reviewed and changes were made.

There is minimal financial impact to property owners. None of the proposed update changes requires an increase in existing fees or creation of new fees.

On April 6, 2017, this procedure was reviewed and found legally sufficient by the WSSC General Counsel's Office.

Public Comment Chronology	
August 31, 2015	Requested review from Engineering and Construction Team, Utility Services Team and Maryland Building Industry Association (MBIA)
October 1, 2015	Comments were received from Engineering and Construction Team, Utility Services Team and MBIA
January 21, 2016	Responses to comments received on October 1, 2015 to Engineering and Construction Team, Utility Services Team and MBIA
January 28, 2016	Requested MBIA to go over the responses to comments.
March 7, 2016	Requested comments from Prince Georges County and Montgomery County Government – Comments due back on April 8, 2016
April 1, 2016	Re-requested Montgomery County Government to review Pipeline Design Manual
April 8, 2016	No Comments from Montgomery County Government. Prince Georges County Government requested more time to review
July 22, 2016	Meeting with Prince Georges County Government staff to go over their comments
February 22, 2017	Received additional comments from MBIA
March 29, 2017	Development Services Group responded to MBIA comments
May 9, 2017	Meeting with Prince Georges County Government staff to go over their comments
May 12, 2017	Meeting with Montgomery County Government staff to go over their comments

# PIPELINE DESIGN MANUAL

2017

WASHINGTON  
SUBURBAN  
SANITARY  
COMMISSION



**REGULATION**

APRIL 19, 2017

# SUMMARY OF MAJOR CHANGES 2017 PIPELINE DESIGN MANUAL

All revisions/changes to this 2017 Pipeline Design Manual is shown with red text.

## GENERAL SECTION

- Add Variance (Waivers) Requirements.

## PART ONE – WATER DESIGN GUIDELINES

### Section 2 – Pipe Materials and Fittings.

- Change standard exterior coating of Ductile Iron Pipe to Zinc Coating.
- Change all Ductile Iron to be Fusion Bond Epoxy Coating.

### Section 4 – Selection of Pipe Material.

- Revised maximum operating pressure for PVC AWWA C-900 to 130 psi.
- Add requirements for PVC AWWA C-900 fittings to have anode protection.
- Added continuity test stations for PVC AWWA C-900 pipe.
- Added Chart on Determining Type of Pipe Material

### Section 8 – Horizontal Alignment.

- Revised location of water pipelines in streets.
- Add looping water systems requirements

### Section 11 – Vertical Alignment (Profiles).

- Revised requirements for crossing ditches and streams.

### Section 17 – Tunnel or Casing Pipes.

- Added requirements for installing casing pipe around existing water pipelines.

### Section 22 – Specialty Valves.

- Added requirements for Flow Control Valves.
- Revised requirements when Pressure Relief Valves.

### Section 24 – Fire Hydrants.

- Added High Traffic Fire Hydrants requirements.

### Section 25 – Water Services Connections.

- Added operating pressures for water services connections.
- Revised new residential services to be 1-1/2 inches.
- Added Ultrasonic Meter requirements.
- Added requirements for replacing existing detector check meters
- Added requirements for connecting to existing PCCP water pipelines.

## PART TWO – SEWER DESIGN GUIDELINES

### Section 5 – General Horizontal Alignment.

- Revised location of water pipelines in streets.

### Section 8 - Vertical Alignment (Profiles).

- Revised requirements for crossing ditches and streams.

### Section 10 – Tunnel or Casing Pipes.

- Added requirements for installing casing pipe around existing sewer or force main pipelines..

### Section 24 – Force Main Design.

- Added High-Density Polyethylene Pipe requirements.

### Section 27 – Sewer Service Connection.

- Added requirements for 8-inch and larger service connections.



## PART THREE – COMMON DESIGN GUIDELINES

### Section 2 – Easements and Construction Strips.

- Changed Right of Way to Easements.

### Section 3 – Pipeline Crossings and Clearances.

- Revised MTA Light Rail Zone of Influence requirements.

### Section 11 – Loading Analysis of Existing Pipelines.

- Added requirements for PVC AWWA C-900 water and sewer pipelines

### Section 16 – Design of Pipeline Structures.

- Added additional requirements.

### Section 22 – Slope Stability.

- Added additional requirements.

### Section 27 – Thrust Restraint Design for Buried Pipelines.

- Revised restrain joint requirements.

### Section 28 – Corrosion Control.

- Revised requirements for Corrosion Protection.

## APPENDIX A – DESIGN CHECKLIST

- Updated Checklist.

## APPENDIX D – WSSC SURVEY AND EASEMENT CRITERIA

- Change Right of Way to Easements.
- Update surveys and easement requirements.

## APPENDIX D – SUBSURFACE INVESTIGATION REQUIREMENTS FOR WATER AND SEWER DESIGN AND CONSTRUCTION.

- Updated requirements for subsurface investigations.

## APPENDIX E – SOIL INVESTIGATION FOR SOFT GROUND TUNNEL PROJECTS.

- Updated requirements for subsurface investigations.



14501 Sweitzer Lane • Laurel, Maryland 20707-5901

COMMISSIONERS

Fausto R. Bayonet, Chair  
Chris Lawson, Vice Chair  
Omar M. Boulware  
Howard A. Denis  
T. Eloise Foster  
Thomasina V. Rogers

GENERAL MANAGER  
Carla A. Reid

**TO THE HOLDERS OF THE WSSC PIPELINE DESIGN MANUAL:**

Enclosed is the 2017 WSSC Pipeline Design Manual, which supersedes and encompasses all the material of the previous Pipeline Design Manual. A Design Checklist is included to assist with the preparation of contract documents for water and sewer pipelines.

This manual takes precedence over all previous water and sewer design documents issued by the WSSC was prepared to serve as a stand alone, ready reference of all WSSC water and sewer design requirements for 54-inch and smaller water mains and all sizes and types of sewers designed according to the WSSC General Conditions and Standard Specifications and the WSSC Standard Details for Construction.

The WSSC's intent in producing this manual was to readily provide the design requirements and practices of the WSSC for systems pipeline projects in order to maintain consistency and ensure the integrity and longevity of the pipeline infrastructure. Adhering to the design requirements herein will simplify the submittal process and minimize design revisions.

It will prove necessary to modify portions of the manual to comply with new design practices and changing technologies. Revisions to this manual can be conveniently downloaded and printed from the WSSC Corporate Website. Instructions for obtaining the revisions from the website are included on the following page. If you have any suggestions for revisions, please fill out and return the revision form in the front of this manual, as your suggestions are valued and greatly appreciated.

Commencing on the date of adoption, this issue of the WSSC Pipeline Design Manual, together with the WSSC Standard Details for Construction and the WSSC General Conditions and Standard Specifications, will be applicable to all new pipeline design projects.

Gary J. Gumm, P.E.  
Chief Engineer

Washington Suburban Sanitary Commission



**PROPOSED REVISIONS**  
to the  
WSSC Pipeline Design Manual

---

---

Manual Part \_\_\_\_\_ Section Number \_\_\_\_\_ Page Number \_\_\_\_\_

Manual Users Name \_\_\_\_\_ Phone (\_\_\_\_) \_\_\_\_\_

Email Address \_\_\_\_\_

Company \_\_\_\_\_

Address \_\_\_\_\_

\_\_\_\_\_

**Proposed Revision:** In the space below, please provide a detailed description of your suggested change or revision to the Pipeline Design Manual. All comments or recommendations for revisions are encouraged to point out discrepancies, suggested modifications or recommendations for additional information, examples, etc. to be added. Please include a descriptive reason for the change or addition, attach any necessary pages and supporting documentation and mail it to the address below.

# OBTAINING MANUAL REVISIONS

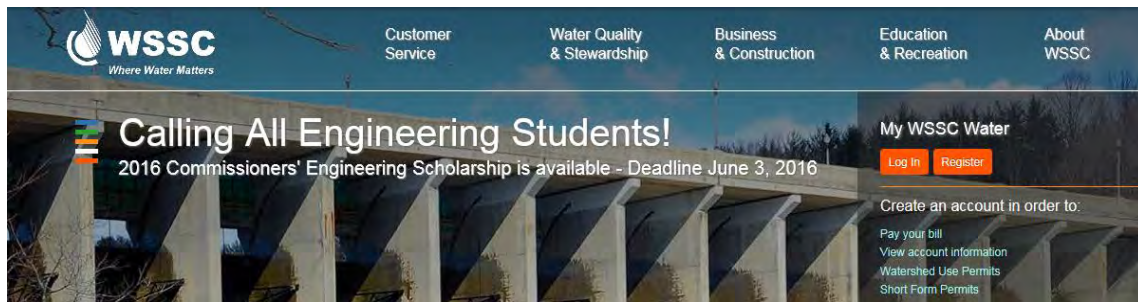

## Attention Manual Holders:

Revisions to the Pipeline Design Manual can be conveniently downloaded and printed from the WSSC Corporate Website. As the holder of the manual, it is *your* responsibility to keep your manual up to date. Prior to the start of any new water and sewer pipeline design for the WSSC, please be sure to visit the website to obtain any revisions and insert them in your manual. Approval of plans may be delayed if the latest design guidelines are not used.

The revisions can be obtained by visiting the WSSC website at <http://www.wsscwater.com/> and clicking on "Business & Construction" from the Navigation Bar. From the pull down menu, select "Doing BusinessCode & Standards" and then "Pipeline Design Manual".

## No Internet Access ??

If you do not have access to the Internet, please contact the WSSC Technical Services Group to obtain a copy of any manual revisions.





# CONTENTS



# TABLE OF CONTENTS

## PIPELINE DESIGN MANUAL

### **Introduction**

#### **General**

Table of Contents  
General

### **Part One - Water Design Guidelines**

General  
Table of Contents

### **Part Two - Sewer Design Guidelines**

General  
Table of Contents

### **Part Three - Common Design Guidelines**

General  
Table of Contents

### **Appendix**

Appendix A Design Checklist  
Appendix B WSSC Design Criteria for Water Distribution Systems  
Appendix C WSSC Design Criteria for Sewer Systems  
Appendix D WSSC Survey and Right of Way Criteria  
Appendix E Subsurface Investigation Requirements for Water and Sewer Design and Construction  
Appendix F Soil Investigation for Soft Ground Tunnel Projects









# INTRODUCTION

## INTRODUCTION

The Washington Suburban Sanitary Commission's Pipeline Design Manual covers the minimum standard criteria to be followed by Designers and Engineers when preparing plans and/or specifications for the design of water and sewer pipelines for the Washington Suburban Sanitary Commission (WSSC) within the Washington Suburban Sanitary District (WSSD). It covers criteria such as submittal requirements, horizontal and vertical alignment, thrust restraint, tunneling, corrosion control, structural requirements, appurtenances, specifications, materials, hydraulics, etc.

This manual is a design guideline that shall be followed and used in conjunction with the WSSC Standard Details for Construction and the WSSC General Conditions and Standard Specifications. It is the Designer's responsibility to review and verify the applicability of all material presented in this manual as it pertains to the specific project under design and to submit, as required by WSSC and herein, all reports, design computations, worksheets, geotechnical investigations, surveys, rights of way determinations, checklists, etc. All such submittals shall be signed and sealed by the Professional Engineer or Professional Land Surveyor, as appropriate, licensed to practice in the State of Maryland, who is in responsible charge of that portion of the project.

This manual covers design guidelines for all pipeline projects under the jurisdiction of WSSC including water mains 54-inch diameter and smaller and all sizes of gravity and pressure sewers with the exception of privately owned and maintained systems referred to as "on-site" systems.

It is the WSSC's policy to avoid and protect environmentally sensitive areas wherever possible including wetlands, woodlands, one hundred (100) year flood plains, park property, steep slopes, historical/archaeological sites, Chesapeake Bay Critical Areas, Areas of Special State Concern and public tree areas.





GENERAL

---

**TABLE OF CONTENTS****GENERAL**

<b>1. Contract Drawings and Documents.</b>	<b>G - 1</b>
a. General	G - 1
<b>2. Variance (Waivers)</b>	<b>G - 2</b>
<b>3. Contract Drawings and Specifications</b>	<b>G - 7</b>
a. General Instructions.	G - 6
b. Utility Coordination.	G - 6
c. Contract Specifications and Special Provisions.	G - 6
d. Data and Flow Computations.	G - 6
e. Estimate of Quantities.	G - 6
<b>4 Additional Requirements.</b>	<b>G - 8</b>
a. Location of Existing Utilities and Physical Features.	G - 8
b. Proposed Construction.	G - 8
c. Design Checklist.	G - 8
d. Discrepancies.	G - 8



---

## GENERAL

### 1. General.

- a. The Washington Suburban Sanitary Commission (WSSC) is authorized by Public Utilities Article, Division II of the Annotated Code of Maryland to adopt, administer and enforce regulations for the design, construction, installation and development of water and sewer systems and their appurtenances. This Design Manual constitutes a duly adopted WSSC regulation.
- b. The purpose of this Design Manual is to provide the minimum requirements and standards which must be followed in the design, construction, installation and development of water and sewer systems within the Washington Suburban Sanitary District. This manual was developed and adopted in an effort to fulfill WSSC's mission of providing safe and reliable water and returning clean water to our environment for the protection of the public health, safety and well-being.

### 2. Variance.

- a. WSSC's Approving Authority shall have the authority to grant a modification, variance and/or waiver ("Variance") of any requirements and/or standards set forth herein on a case-by-case basis when the determinations set forth in paragraph 2.b.3) below have been made. Records of action granting a Variance shall be maintained by the WSSC's Approving Authority.
- b. Request for Variance.
  - 1) A Variance request shall be submitted on the WSSC Official Variance Request Form. The form shall be signed by the Applicant and Applicant's Engineer (the "Engineer").
  - 2) Variance requests may be subject to an additional fee.
  - 3) A Variance request may be granted in whole or in part, when WSSC's Approving Authority has determined that:
    - a) Strict compliance with the Design Manual is impractical;
    - b) The Variance is in conformity with the intent and purpose of the Design Manual;
    - c) The Variance does not compromise safety, health, life or fire safety standards or requirements;
    - d) The Variance does not pose a threat or cause damage to WSSC's water or sewer system or appurtenances;
    - e) Denial of the Variance will result in undue burden or undue hardship to the Owner;and
    - f) The grant of the Variance will be in the public interest.



- 4) Design drawings and calculations: A Variance request shall be accompanied by design drawings, plans, calculations, product literature and other documentation as necessary to document and support the requested Variance and justification for the Variance.
- 5) Indemnification. To obtain a Variance, the Applicant must sign the hold-harmless agreement section of the Variance request form, and agree to indemnify WSSC and its Commissioners, officers, agents and employees as described therein.



**WASHINGTON SUBURBAN SANITARY COMMISSION  
OFFICIAL VARIANCE REQUEST**

**JOB NAME:** \_\_\_\_\_ **WSSC JOB NUMBER:** \_\_\_\_\_

**DATE OF REQUEST:** \_\_\_\_\_

**DESCRIPTION OF REQUESTED VARIANCE**

(INCLUDE APPLICABLE PIPELINE DESIGN MANUAL SECTION AND REFERENCES):

**JUSTIFICATION FOR REQUESTED VARIANCE**

Applicant's Signature \_\_\_\_\_

Print Name \_\_\_\_\_

Address \_\_\_\_\_

Phone \_\_\_\_\_ e-mail \_\_\_\_\_

Engineer's Signature \_\_\_\_\_

Print Name \_\_\_\_\_

Address \_\_\_\_\_

Phone \_\_\_\_\_ e-mail \_\_\_\_\_





**WASHINGTON SUBURBAN SANITARY COMMISSION  
OFFICAL VARIANCE REQUEST**

**JOB NAME:** \_\_\_\_\_ **WSSC JOB NUMBER:** \_\_\_\_\_

**HOLD HARMLESS AGREEMENT**

To the fullest extent permitted by law, the undersigned Applicant agrees to indemnify, defend and save harmless the Washington Suburban Sanitary Commission and its Commissioners, Officers, Agents and Employees from and against any and all claims, suits, actions, losses, damages, expenses, costs, injuries and liabilities of any nature (including but not limited to claims for bodily injury, death, business interruption and/or property damage) relating to, arising out of or resulting from the granting and/or implementation of the Variance requested herein.

Applicant's Signature \_\_\_\_\_  
Print Name \_\_\_\_\_  
Address \_\_\_\_\_  
\_\_\_\_\_  
Phone \_\_\_\_\_ e-mail \_\_\_\_\_



**WASHINGTON SUBURBAN SANITARY COMMISSION  
OFFICAL VARIANCE REQUEST**

**JOB NAME:** \_\_\_\_\_ **WSSC JOB NUMBER:** \_\_\_\_\_

**FOR WSSC USE ONLY**

**DATE RECEIVED:** \_\_\_\_\_

**ACTION TAKEN:**     Approved \_\_\_\_\_     Denied \_\_\_\_\_

**EXPLANATION OF ACTION / SPECIAL CONDITIONS OF VARIANCE:**

**SIGNATURE:** \_\_\_\_\_ **DATE:** \_\_\_\_\_  
                            WSSC's Approving Authority



# WASHINGTON SUBURBAN SANITARY COMMISSION OFFICIAL VARIANCE REQUEST

## INSTRUCTIONS FOR COMPLETING FORM

1. A single waiver is acceptable for projects with the same job number and different alpha suffixes (e.g. DA1234Z05, DA1234A05, DA1234B05, and DA1234C05).
2. In the same box with Job Number, list the Permit No. or On-Site Plan No. if applicable.
3. The Description of and Justification for the Variance must be detailed and complete.
4. Give details such as elevations, lengths, existing conditions, job related limitations, etcetera. Attach supporting documentation, (e.g. letters from County, MNCP+PC) if this supports your request.
5. Attach any applicable documents (e.g. plans, drawings, calculations, product literature etc.).
6. The Applicant must sign the form. The Engineer shall not sign as the Applicant.
7. The Engineer's signature is required.
8. The Variance form and supporting information must be uploaded into ePlan Review or e-builder as a single PDF into the Documents Folder.
9. Determination of the Variance request will be posted in the approved folder in ePlan review or e-builder.
10. Contact the WSSC's Project Manager assigned to the project, if you have questions regarding this form.



---

### 3. Contract Drawings and Specifications.

#### a. General Instructions.

- 1) Prepare plans on WSSC standard size drawings, contact **WSSC's Project Manager** for standards.
- 2) Each drawing shall have the professional seal, signature and registration number of the licensed engineer responsible for the design.
- 3) Include notes common to all contract drawings on the first sheet of the set and labeled as General Notes, Blocking Notes, Miss Utility Note, Dependency Note, etc., as required.
- 4) All plans, profiles and details shall be drawn to scale unless otherwise approved or directed by WSSC. Plan view scales shall be 1" = 50' except for townhouses/cluster type developments or congested areas where 1" = 30' scale shall be used. Draw profiles to horizontal scale 1" = 100' and vertical scale 1" = 10' except for large diameter mains 24-inches and larger, where the profile shall use the same horizontal scale as the plan.

#### b. Utility Coordination.

- 1) Closely coordinate all water and sewer pipeline design and construction with storm drains and all other utility design and construction so that there are no conflicts. Accurately show on the plans and profiles the location of both future and/or existing storm drains and all other utilities.

#### c. Contract Specifications and Special Provisions.

- 1) Prepare the contract specifications and/or special provisions according to WSSC standards, as required. For additional information regarding special provisions, see Part Three, Section 6 (Modifications to Specifications and Standard Details).

#### d. Design Data and Flow Computations.

- 1) Furnish design data and computations as indicated in this manual. The design data and computations must be clear and legible, and sealed and signed by a Professional Engineer. Submit this data along with the design, unless otherwise indicated by **WSSC's Project Manager**.

#### e. Estimate of Quantities.

- 1) Furnish a tabulated estimate of quantities and costs, including contingency items, if required by WSSC. The tabulated estimate must be clear and legible, and sealed and signed by a Professional Engineer. Submit this data along with the design, when required by **WSSC's Project Manager**.



---

#### 4. Additional Requirements.

##### a. Location of Existing Utilities and Physical Features.

- 1) The Designer is responsible for obtaining locations of all existing utilities and physical features through field surveys and as-built record information. When directed by the WSSC's Project Manager, obtain test pits wherever exact locations of underground utilities are uncertain, and/or where locations are critical to design. The WSSC will assist in the coordination of test pits as deemed necessary. The number, location and type of test pits will be dictated by specific design requirements.

##### b. Proposed Construction.

- 1) Research all pertinent data on all proposed construction projects which may impact the design and coordinate the same with the development of the contract drawings and specifications.

##### c. Design Checklist.

- 1) The Design Checklist, Appendix A, can be used as a design guide for preparing water and sewer pipeline designs according to this design manual. Items listed in the design checklist are general and may not cover all items that may be required to complete the specific project under design. The Designer is fully responsible for preparing complete contract documents. The WSSC is not responsible for design items which may be required but are not included on the Design Checklist.

##### d. Discrepancies.

- 1) Whenever any conflict, discrepancy or ambiguity exists within this manual or between any code, regulation or policy promulgated by any other jurisdictional agency within the WSSD, advise WSSC immediately in writing and WSSC's Project Manager will render expeditious interpretations and guidelines to be followed.





# PART ONE

# Water Design Guidelines

## PART ONE

# WATER DESIGN GUIDELINES

### **General.**

Part One of the Pipeline Design Manual covers the minimum standard design criteria to be followed when preparing the design of water pipelines and appurtenances within the Washington Suburban Sanitary District (WSSD). Use this part in conjunction with Part Two, Sewer Design Guidelines and Part Three, Common Design Guidelines. Although this manual is intended as a guideline, it is the Designer's responsibility to review and verify the applicability of all material presented herein as it pertains to the specific project under design.

The portions of the water supply system which are considered as the property and responsibility of the WSSC are the water pipelines, appurtenances and those portions of the water service connections which lie in the public right of way and in rights of way granted to the WSSC. All other systems are in most cases the responsibility of the respective property owner(s).

For projects that are constructed and maintained by WSSC, WSSC will indicate the size and limits of the water pipeline(s) and appurtenances to be designed and constructed. The WSSC Design Criteria for Water Distribution Systems are found in Appendix B.

In the preparation of the contract documents, the Designer will take into full account such matters as environmental impact, public impact including maintenance of pedestrian and vehicular traffic, maintenance of existing and proposed utility services, constructability, and system maintenance to produce the most cost-effective design.



## TABLE OF CONTENTS

### PART ONE - WATER DESIGN GUIDELINES

<b>1. Terminology and Abbreviations.</b>	<b>W - 1.1</b>
a. General.	W - 1.1
b. Types of Pipelines.	W - 1.1
c. WSSC Documents.	W - 1.1
d. Pipe Material.	W - 1.1
e. Miscellaneous.	W - 1.2
<b>2. Pipe Materials and Fittings.</b>	<b>W - 2.1</b>
a. General.	W - 2.1
b. Pipe Material.	W - 2.1
c. Fittings.	W - 2.2
<b>3. Pipe and Fitting Joints.</b>	<b>W - 3.1</b>
a. Specifications Requirements.	W - 3.1
b. Type of Allowable Joints.	W - 3.1
c. Joint Requirements for Pipe and Fittings.	W - 3.2
d. Insulation Joint Requirements.	W - 3.2
<b>4. Selection of Pipe Material.</b>	<b>W - 4.1</b>
a. General.	W - 4.1
b. Determining Pipeline Cover.	W - 4.1
c. Selection of Pipe Material, Pipe Class and Wall Thickness.	W - 4.1
d. Determining Type of Pipe Material.	W - 4.4
e. Depth of Cover for DIP Greater Than WSSC Requirements.	W - 4.5
f. Wall Thickness of DIP for Special Applications.	W - 4.5
g. When pipelines are to be designed near or within Marlboro Clay.	W - 4.6
<b>5. Total Internal and Transient Pressures.</b>	<b>W - 5.1</b>
a. Total Internal Pressure.	W - 5.1
b. Operating Pressure.	W - 5.1
c. Surge (Transient) Pressures.	W - 5.2
<b>6. Buckling Designs.</b>	<b>W - 6.1</b>
a. Criteria.	W - 6.1
b. References.	W - 6.1
<b>7. Allowable Fittings.</b>	<b>W - 7.1</b>
a. General Requirements.	W - 7.1
b. Design Considerations.	W - 7.1
c. Type of Fittings.	W - 7.2





<b>8. Horizontal Alignment.</b>	<b>W - 8.1</b>
a. General.	W - 8.1
b. Considerations.	W - 8.1
c. Location.	W - 8.1
d. <b>Looping Water Systems</b>	<b>W - 8.2</b>
e. Labeling Pipeline in Plan.	W - 8.2
<b>9. Connections to Existing or Proposed Water Pipelines.</b>	<b>W - 9.1</b>
a. Design of Connections to Existing Pipelines.	W - 9.1
b. Revising Designed Connections During Construction.	W - 9.2
c. Connection to Proposed or Future Pipelines.	W - 9.3
d. Labeling Existing Pipelines on the Drawings.	W - 9.3
e. Special Items.	W - 9.3
<b>10. Relocating Water Pipelines.</b>	<b>W - 10.1</b>
a. General.	W - 10.1
b. Alignment - Horizontal and Vertical.	W - 10.1
c. Thrust Restraint.	W - 10.2
d. Abandonment.	W - 10.2
<b>11. Vertical Alignment (Profiles).</b>	<b>W - 11.1</b>
a. Cover Over Pipeline.	W - 11.2
b. Labeling Pipeline in Profile.	W - 11.2
c. Change in Vertical Alignment.	W - 11.2
d. Stations and Elevations.	W - 11.2
e. Design of Structures on Profile.	W - 11.2
f. Profile Grade Lines.	W - 11.3
g. Length of Profile.	W - 11.4
h. Pipeline Stationing.	W - 11.4
<b>12. Allowable Joint Deflections.</b>	<b>W - 12.1</b>
a. General.	W - 12.1
b. DIP and PVC with Push-on <b>Type Joints</b>	W - 12.1
c. DIP Mechanical Joints.	W - 12.2
d. Restrained Joint Pipe.	W - 12.2
e. Determining Joint Deflections and Offset Distances.	W - 12.5
<b>13. Rotation of Fittings.</b>	<b>W - 13.1</b>
a. Rotation of Bends.	W - 13.1
b. Rotation of Tees.	W - 13.6
c. Rotation of Other Fittings.	W - 13.6
<b>14. Joint Deflections at Fittings.</b>	<b>W - 14.1</b>
a. Requirements.	W - 14.1
<b>15. Deflection of Pipe Joints.</b>	<b>W - 15.1</b>
a. General.	W - 15.1
b. Alignment Design.	W - 15.1



<b>16. Design of Structures.</b>	<b>W - 16.1</b>
a. Standard Details.	W - 16.1
b. Special Design Structures.	W - 16.1
c. Design of Structures on Profiles.	W - 16.1
d. Access Openings.	W - 16.1
e. Setting of Frames and Covers or Hatches.	W - 16.1
f. Labeling Structures on the Drawings.	W - 16.2
<b>17. Tunnels or Casing Pipes.</b>	<b>W - 17.1</b>
a. Requirements.	W - 17.1
b. Installing Casing Pipes for Existing Water Pipelines.	W - 17.1
<b>18. Pipeline Valves.</b>	<b>W - 18.1</b>
a. General.	W - 18.1
b. Valve Types	W - 18.1
c. Valve Locations	W - 18.1
d.. Special Requirements.	W - 18.2
e.. Valve Size.	W - 18.2
f. Valve Spacing.	W - 18.2
g. Restraining of Valves.	W - 18.3
h. Plan Design Information.	W - 18.3
i. Profile Design Information.	W - 18.3
j. Type of Valves (Double Disc Gate Valves and Resilient Seated (Wedge) Gate Valve).	W - 18.4
k. Horizontal Gate Valve Vault Design for Pipelines Larger Than 16-inch Diameter.	W - 18.5
<b>19. Air Valves.</b>	<b>W - 19.1</b>
a. General.	W - 19.1
b. Specification Requirements.	W - 19.1
c. Design Requirements for 16-inch and Larger Pipelines.	W - 19.1
d. Sizing of Air/Vacuum Valves.	W - 19.2
e. Sizing of Air Release Valves.	W - 19.2
f. Location of the Air Valve or Combination Air and Vacuum Valve.	W - 19.3
g. Connecting the Air Valve or Combination Air and Vacuum Valve to the Mainline Pipe.	W - 19.4
h. Piping and Vault Configuration.	W - 19.4
<b>20. Entry Ports.</b>	<b>W - 20.1</b>
a. General Requirements.	W - 20.1
b. Piping and Vault Configuration.	W - 20.1
<b>21. Air Valves with Entry Port.</b>	<b>W - 21.1</b>
a. General Requirements.	W - 21.1
b. Piping and Vault Configuration.	W - 21.1



<b>22. Specialty Valves.</b>	<b>W - 22.1</b>
a. Type of Specialty Valves.	W - 22.1
b. General Requirements for Valve and Piping Arrangement in Vaults.	W - 22.1
c. Altitude Valves.	W - 22.3
d. Pressure Reducing Valves (PRV).	W - 22.4
e. Flow Control Valves (FCV)	W - 22.7
h. Pressure Relief Valves (Relief Valve).	W - 22.7
i. Swing Check Valves.	W - 22.10
j. Backflow Preventers.	W - 22.11
k. Butterfly Valves.	W - 22.11
l. Eccentric Plug Valves.	W - 22.12
m. Line Stop	W - 22.13
<b>23. Blowoff Connections.</b>	<b>W - 23.1</b>
a. Design Requirements for Blowoff Connections.	W - 23.1
b. Types of Blowoff Connections.	W - 23.1
c. Blowoff Connection to the Mainline Pipeline.	W - 23.2
d. Drawing Requirements for Blowoffs.	W - 23.3
<b>24. Fire Hydrants.</b>	<b>W - 24.1</b>
a. General Requirements.	W - 24.1
b. Type of Fire Hydrants	W - 24.1
c. Fire Hydrant Settings (Horizontal).	W - 24.2
d. Fire Hydrant Leads.	W - 24.2
e. Fire Hydrant Spacing.	W - 24.3
<b>25. Water Service Connections (WHC).</b>	<b>W - 25.1</b>
a. General Requirements.	W - 25.1
b. Operating Pressure for WHC's	W - 25.1
c. Types of WHCs.	W - 25.1
d. Size of WHCs.	W - 25.2
e. Allowable Pipe Material for WHCs.	W - 25.2
f. Horizontal WHC Alignment.	W - 25.3
g. Vertical WHC Alignment.	W - 25.5
h. Location of Outside Meters.	W - 25.6
i. Connection of the WHC to the Mainline Pipeline.	W - 25.8
j. Insulated Joints on WHCs.	W - 25.9

## CHARTS

<b>Chart "E"</b>	<b>Selection of Pipe Material.</b>	<b>W - 4.4</b>
<b>Chart "A"</b>	<b>Rotation of Bends.</b>	<b>W - 13.5</b>

## FIGURES

<b>Figure "A"</b>	<b>Pipeline Joint Deflections.</b>	<b>W - 12.5</b>
-------------------	------------------------------------	-----------------



## SKETCHES

<b>Sketch "B"</b>	Location of Welded-on Connection, Flanged Pipe.	W - 7.5
<b>Sketch "C"</b>	Location of Welded-on Connection, Pipe Other Than Flanged Pipe.	W - 7.6
<b>Sketch "D"</b>	Rotation of Bends (Horizontal and Vertical).	W - 13.2
<b>Sketch "E"</b>	Profile - Rotation of Bends.	W - 13.3
<b>Sketch "F"</b>	Profile - Deflections at Pipe Joints.	W - 15.2
<b>Sketch "G"</b>	Labeling Manholes or Vaults on Proposed or Finished Grades.	W - 16.2
<b>Sketch "H"</b>	Labeling Manholes or Vaults on Existing Grades.	W - 16.2
<b>Sketch "I"</b>	Maximum Pipe Slope for Valves.	W - 18.3
<b>Sketch "J"</b>	WHC Lowering at Storm Drains and Other Utility Crossings.	W - 25.5

## TABLES

<b>Table "1"</b>	Surge Pressures.	W - 5.2
<b>Table "3"</b>	Deflection Table - DIP Push-on Joint Pipe.	W - 12.1
<b>Table "3.1"</b>	Deflection Table - PVC Pipe with Push-on Joints.	W - 12.1
<b>Table "4"</b>	Deflection Table - DIP Mechanical Joint Pipe.	W - 12.2
<b>Table "5.0"</b>	Deflection Table - Wedge Action Restraining Glands – Mechanical Joint DIP.	W - 12.3
<b>Table "5.0a"</b>	Maximum Total Pressure for Wedge Action Restraining Glands for DIP.	W - 12.3
<b>Table "5.1"</b>	Deflection Table - Manufacturer's Proprietary Restrained Joint DIP - Push-on Restrained Joint Gaskets.	W - 12.3
<b>Table "5.2"</b>	Deflection Table - Manufacturer's Proprietary Restrained Joint DIP.	W - 12.4
<b>Table "5.3"</b>	Deflection Table - Wedge Action Restraining Glands - DIP Push-on Joints.	W - 12.4
<b>Table "5.3a"</b>	Maximum Total Pressure for Wedge Action Restraining Glands – DIP Push-on Joints.	W - 12.4
<b>Table "5.4"</b>	Deflection Table - Wedge Action Restraining Glands – Push-on PVC Pipe.	W - 12.5
<b>Table "6"</b>	Valve Sizes.	W - 18.2
<b>Table "7"</b>	Spacing of Valves.	W - 18.2



## 1. Terminology and Abbreviations:

The following terms and abbreviations are used in Part One of the Design Manual.

### a. General.

<b>WSSC</b>	Washington Suburban Sanitary Commission.
<b>WSSD</b>	Washington Suburban Sanitary District.
<b>AWWA</b>	American Water Works Association.
<b>ANSI</b>	American National Standards Institute.
<b>AISI</b>	American Iron and Steel Institute.
<b>AASHTO</b>	American Association of State Highway and Transportation Officials.
<b>DIPRA</b>	Ductile Iron Pipe Research Association.
<b>MDE</b>	Maryland Department of the Environment.
<b>MSHA</b>	Maryland State Highway Administration.

### b. Types of Pipelines.

<b>Distribution Mains</b>	Water pipelines (4-inch to 12-inch) designed and constructed to provide localized services.
<b>Transmission Mains</b>	Water pipelines (16-inch and larger) designed and constructed to provide a major water supply from the water treatment plant to the Distribution Mains.

### c. WSSC Documents.

<b>SEP</b>	System Extension Process.
<b>DRP</b>	Developer Relocation Projects
<b>Specifications</b>	WSSC General Conditions and Standard Specifications.
<b>Standard Details</b>	WSSC Standard Details for Construction.
<b>Drawings</b>	Contract Design Drawings.
<b>Plumbing Code</b>	WSSC Plumbing and Fuel Gas Code.

### d. Pipe Material.

<b>DIP</b>	Ductile Iron Pipe.
<b>CIP</b>	Cast Iron Pipe.
<b>PCCP</b>	Prestressed Concrete Cylinder Pipe.
<b>PVC (AWWA C900)</b>	Polyvinyl Chloride (Water Pipe)
<b>ACP</b>	Asbestos Cement Pipe.



**e. Miscellaneous.**

<b>psi</b>	pounds per square inch.	<b>ID</b>	Pipe inside diameter.
<b>HHG</b>	High Hydraulic Grade.	<b>OD</b>	Pipe outside diameter.
<b>LHG</b>	Low Hydraulic Grade.	<b>R/W</b>	<b>Public Road</b> Right of Way.
<b>SHC</b>	Sewer <b>Service (House)</b> Connection.	<b>PIE</b>	Public Improvement Easement.
<b>WHC</b>	Water <b>Service (House)</b> Connection.	<b>PUE</b>	Public Utility Easement.
<b>PE</b>	Plain End Joint.	<b>MJ</b>	Mechanical Joint.
<b>FLG</b>	Flange Joint.	<b>TS&amp;V</b>	Tapping Sleeve and Valve.
<b>DR</b>	Dimension Ratio.	<b>SDR</b>	Standard Dimension Ratio.



## 2. Pipe Materials and Fittings.

### a. General.

- 1) Standard pipe materials and fittings. Ensure that all designs allow for the use of materials that conform to all applicable sections of the Specifications and the Standard Details.
- 2) Special pipe materials and fittings. Submit any special design features and/or materials required due to the specific nature of the contract for approval, prior to being incorporated into the contract documents. If approved, it will be for the specific case in question and is not to be considered a general approval for use elsewhere (other contract documents). Provide Special Provisions to the Specifications and Modifications to the Standard Details; see Part Three, Section 6 (Modifications to Specifications and Standard Details).

### b. Pipe Material.

- 1) Standard Pipe Material.

- a) DIP in accordance with the Specifications, with the class of pipe noted on the drawings.

(1) Minimum pipe of class of pipe is Class 54.

(2) Design the class of pipe (wall thickness) for the allowable cover; see Part One, Section 4 (Selection of Pipe Material).

(3) Exterior Coating Systems for DIP.

(a) Standard coating shall be zinc basecoat applied to pipe surface and asphaltic topcoat, and must have V-Bio encasement in accordance with the Specifications.

(b) Special exterior coating systems with cathodic protection system in accordance with the Specifications may be required. For additional information on cathodic protection system; see Part Three, Section 28 (Corrosion Control).

(4) DIP larger than 48-inch diameter:

(a) Verify with the pipe manufacturer that the material specified can be produced. For example: Larger sized DIP may be available in Pressure Class instead of Class of Pipe.

(b) The design pipeline must be reviewed for acceptable working pressure and cover over the pipe and Special Provisions to the Specifications will be required to be submitted for review.

(5) Allowable pipe joints see Part One, Section 3 (Pipe and Fitting Joints).



- b) **PVC - AWWA C900 in accordance with the Specifications with the pipe dimension ratio (DR) noted on the drawings.**
- (1) For pipe sizes 12-inch and smaller
  - (2) Pipe dimension Ratio is DR14
  - (3) Operating pressure, allowable cover and pipe dimension ratio (DR); see Part One, Section 4 (Selection of Pipe Material) for design information.
  - (4) Allowable pipe joints see Part One, Section 3 (Pipe and Fitting Joints).
  - (5) Alternatives to the insulating flanges for 12-inch and smaller ductile iron water mains, as shown in Standard Details C/3.1, C/3.2, and C/3.3, see Standard Detail C/3.2a for PVC insulating spool. For operating pressure, allowable cover and pipe dimension ratio (DR), see Part One, Section 4 (Selection of Pipe Material) for design information.
- c) **Steel Pipe.** The use of steel pipe for water pipelines is for special cases only, where it proves to be the most suitable material for the particular design.
- (1) Pipe in accordance with AWWA M-11 (Steel Pipe - A Guide for Design and Installation) and AISI Welded Steel Pipe, Steel Plate Engineering Data, Volume 3.
  - (2) Use E' [Modulus of soil reaction] for soil shall be four hundred (400) psi.
  - (3) Specify continuous interior lining and exterior coatings and cathodic protection system.
  - (4) Joints:
    - (a) For 42-inch and smaller steel pipe shall be continuous butt-welded joints.
    - (b) For 48-inch and larger steel pipe double lap weld joints
  - (5) Design for steel pipeline generally the same as for DIP.
- d) **Copper Pipe.** See Part One, Section 25 (Water Service Connections).

**c. Fittings.**

- 1) **Standard Fitting Material.**
  - a) Fittings for DIP and PVC in accordance with the Specifications and the following:
    - (1) Ductile iron in accordance with AWWA C110 or AWWA C153.
    - (2) All Ductile Iron Fitting shall have fusion bond epoxy coating in accordance with AWWA C116





- (3) Polyethylene encasement; see requirements for DIP material.
- (4) Standard exterior coating in accordance with the Specifications. The design may require special coatings or protection; see Part Three, Section 28 (Corrosion Control).
- (5) Fittings larger than 48-inch diameter are to be designed for a working pressure rating of 150 psi. 48-inch and smaller diameter fittings are to be designed for a working pressure rating of 250 psi.
  - (a) Each fitting's working pressure must be reviewed and if the working pressure is over the pressure rating of the fitting, then approval and Special Provisions to the Specifications will be required.
- (6) For allowable joints on fittings see Part One, Section 3 (Pipe and Fitting Joints).
- (7) For allowable fittings and special design requirements see Part One, Section 7 (Allowable Fittings).
- b) Fittings for Steel Pipe. The use of fittings for steel pipelines is for special cases only see requirements for steel pipe in this section.
  - (1) Fittings in accordance with AWWA M-11 (Steel Pipe - A Guide for Design and Installation) and AISI Welded Steel Pipe, Steel Plate Engineering Data, Volume 3.
  - (2) Specify continuous interior lining and exterior coatings and cathodic protection system.
- (5) Joints:
  - (c) For 42-inch and smaller steel pipe shall be continuous butt-welded joints.
  - (d) For 48-inch and larger steel pipe double lap weld joints.



### 3. Pipe and Fitting Joints.

#### a. Specifications Requirements.

- 1) DIP in accordance with the Specifications, and AWWA C110, C111 and C115.
- 2) PVC pipe in accordance with the Specifications and AWWA C900 and C907.
- 3) For joints on Steel Pipe, see requirements in Part One, Section 2 (Pipe Materials and Fittings).

#### b. Types of Allowable Joints.

- 1) For DIP 54-inch and smaller allowable joints include:
  - a) Mechanical joint bell.
  - b) Plain end (for mechanical joint or push-on).
  - c) Push-on bell joints. Restrain joints, if required, by means of a restrained joint gasket for pipe sizes 4-inch through 24-inch and proprietary restrained joints for pipe sizes 16-inch and larger.
  - d) Flanged joints.
    - (1) Two class of flanges:
      - (a) Class 125 flanges in accordance with AWWA C110.
      - (b) Class 250 flanges in accordance with ANSI B/16.1, full-face gaskets.
    - (2) Buried flanged joints are generally not desirable because of the rigidity of the joint, however, the use of buried insulated flanged joint is allowed; see Insulating Joints, this section.
    - (3) Design all vault and interior building piping and fittings with flanged pipe, except as follows:
      - (a) Tapping sleeve and valve in vaults.
      - (b) Mechanical joint solid sleeves in vaults, if used in lieu of mechanical couplings. See requirements for Solid Sleeves and Mechanical Couplings under Part One, Section 7 (Allowable Fittings).
    - (4) When connecting to Class 250 flanged gate valve, the flanged connecting pipe must have ANSI B16.1, Class 250 flanges. For design limitations see Design Requirements for Gate Valves, Part One, Section 18 (Pipeline Valves).
    - (5) 54-inch diameter, ANSI B16.1, Class 250 flanges may not be available. Verify availability during the design.
    - (6) Flanged joints are considered as a restrained joint.
- 2) For PVC 12-inch and smaller: Push-on bell joints.



- 3) For Steel Pipe: Continuous butt-welded pipe joints, unless otherwise approved.

**c. Joint Requirements for Pipe and Fittings.**

1) Pipe Joints.

- a) DIP and PVC pipes must use push-on bell joints unless otherwise noted on the drawings or Standard Details.
- b) Mechanical joint bell for DIP may be used in the design for pipe sizes 24-inch and smaller diameter. Verify the availability of pipe sizes before specifying in the design.
- c) Flanged joints for DIP require a minimum class 54 DIP and that the flanges are threaded and screwed on the pipe by the manufacturer in accordance with AWWA C115.
- d) For requirements for polyethylene encasement or special coatings, see Part One, Section 4 (Selection of Pipe Material).

2) Fitting Joints.

- a) For DIP, the allowable fitting joints includes:
  - (1) Mechanical joint or push-on bell joints for 48-inch and smaller pipe sizes in accordance with AWWA C110. Push-on bell joints for compact fittings in accordance with AWWA C153, unless otherwise noted on the drawings or Standard Details.
  - (2) For 54-inch fittings, push-on bell joints in accordance with AWWA C153 and the manufacturer's standards. Special considerations for operating pressure over 150 psi; see Part One, Section 2 (Pipe Material and Fittings) and Part One, Section 4 (Selection of Pipe Material).
  - (3) Flanged joints see Type of Joints under this section.
- 3) For joint deflection design criteria, see Part One, Section 12 (Allowable Joint Deflections) and Section 14 (Joint Deflections at Fittings).

**d. Insulated Joint Requirements.**

- 1) Flanged DIP short piece (flanged by plain end) is allowed, however this is the only case in which flanged joints are approved for use in direct buried pipelines, see Standard Details C/3.1, C/3.2 and C/3.3.
- 2) PVC insulating spool is allowed as an alternative to an insulating flange for 12-inch and smaller ductile iron water mains, see Part One, Section 4 (Selection of Pipe Material), and Standard Detail C/3.2a.
- 3) For the design criteria for insulating joints, see Standard Details and Part Three, Section 28 (Corrosion Control).



## 4. Selection of Pipe Material.

### a. General.

- 1) Allowable water pipe material for routine projects in accordance with the Specifications are as follows:
  - a) Water Pipelines:
    - (1) DIP or PVC for pipelines 12-inch diameter and smaller.
    - (2) DIP for pipelines larger than 12-inch diameter.
  - b) Water services:
    - (1) Copper tubing for water house services 2-inch diameter and smaller.
    - (2) DIP for 4-inches to 12-inch diameter.
- 2) In the General Notes indicate the minimum pipe class designation.
  - a) On the profiles when required, indicate the change in pipe class designation and give stations to show the limits of pipe class designation.
- 3) For special projects, when pipe diameters exceed 54-inch or for special applications, the WSSC may require a special pipe material, such as steel.

### b. Determining Pipeline Cover.

- 1) Determine the maximum pipeline cover using the largest differential between the profile grade or ground line shown on profile and the pipe crown.

### c. Selection of Pipe **Material**, **Pipe Class** and **Pipe Wall Thickness**.

- 1) Copper tubing. See Specifications.
- 2) DIP in accordance with AWWA C151. The design for DIP shall be based on the allowable cover over the pipeline and the following:
  - a) Class of DIP, in accordance with AWWA C151 as specified as Special Pipe Classes.
    - (1) In the General Notes on the drawings, indicate the minimum class of pipe for DIP required for the project.
    - (2) On the profile indicate by pipeline stations any changes to the class of pipe.
    - (3) Minimum class 54 for all pipe sizes. For determining actual class of pipe higher than the minimum class 54, see the following:



- (a) Class of pipe (i.e. wall thickness) is indicated in Standard Detail W/6.0 and differs for various depths of cover. Use Standard Detail W/6.0 for determining allowable earth cover over DIP. Standard Detail W/6.0 assumes that bedding and backfill are in accordance with the Specifications and the classes of pipe are adequate for all operating pressures in the WSSC's water distribution system. For depth of cover greater than Standard Detail W/6.0, see "Depth of Cover for DIP Greater Than WSSC Requirements" in this section.
  - (b) Larger than 48-inch diameter may not be manufactured in accordance with the Specifications. Verify with the pipe manufacturers that the material specified can be produced. Example: Larger size DIP may be available in Pressure Class instead of Class of Pipe. The pipeline design must be reviewed for allowable working pressure and cover over the pipe, and Special Provisions for Pressure Class must be added to the Specifications, see requirements under Part Three, Section 6, (Modifications to Specifications and Standard Details).
  - (c) Pipelines with welded-on connections see Part One, Section 7 (Allowable Fittings).
  - (d) Flanged pipe, minimum class 54, in accordance with AWWA C115.
  - (e) Pipelines designed within MSHA right of way, see Wall Thickness of DIP for Special Applications, in this section.
- (4) Pipeline crossing under a railroad; verify with the railroad authority the requirements for crossing its property or right of way.
- (a) When crossing under Maryland Transit Administration (MTA) Rail Lines, see Part Three, Section 3 (Pipeline Crossings and Clearances).
- (5) Pipelines within tunnels and casing pipes see Part One, Section 17 (Tunnels or Casing Pipes) and Part Three, Section 26 (Tunnel Design Criteria)
- 3) PVC pipe in accordance with AWWA C900 for 12-inch and smaller diameters. The design for PVC pipe shall be based on the operating pressure and cover over the pipeline.
- a) Pipe dimension ratio for PVC AWWA C900.
    - (1) For 4-inch through 12-inch diameter:
      - (a) Use only AWWA C900 DR14 Pipe Dimension Ratio (DR).
      - (b) Maximum operating pressure is one hundred thirty (130) psi.
  - b) Allowable cover for PVC Pipe AWWA C900.
    - (1) For allowable cover over PVC pipe use Standard Detail W/6.1. Allowable cover differs for varying DRs and trench backfill. Standard Detail W/6.1 assumes bedding and backfill are in accordance with the Specifications.



c) Design limitations.

- (1) PVC pipe has a strict limitation on joint deflections; see Part One, Section 12 (Allowable Joint Deflections).
- (2) **Do not use** PVC pipe for fire hydrant lead piping and for water house connections.

d) Information required on the Drawings.

- (1) In the General Notes on the drawings, indicate the pipe dimension ratio (DR 14) for PVC Pipe.
- (2) **All fitting on PVC AWWA C900 pipe shall be fusion bonded ductile iron fittings, all fittings, valves and tapping sleeve and valves, hydrants, saddles and retrain joints shall have anode protection; See Standard Details C/7.0, C/7.1, C/7.2, C/7.3, C/7.4, C/7.5, C/7.6, C/7.7, C/7.8, C7.9, C7.10 and C/7.11**
- (3) If granular material bedding is required due to the depth of cover, see "Allowable cover for PVC (AWWA C900)" in this section. Show on the profile by pipeline stations the required limits of granular material bedding and provide a note for borrow aggregate within the pipe embedment zone for Standard Detail M/8.1a.
- (4) **PVC AWWA C900** water mains require a tracer wire on top of the PVC pipe, in accordance with the Specifications.
  - (a) The tracer wire shall be placed **on top of the PVC AWWA C900 pipe and to be connected to a Continuity Test Stations; see Standard Details W/9.0 and W/9.1.**
    - [1] **Locate Continuity Test Stations next to all fire hydrants; see Standard Details W/9.1.**
    - [2] **If spacing between Continuity Test Stations is over eight hundred (800) feet, provide Continuity Test Stations every five hundred (500) feet; see Standard Details W/9.0.**
    - [3] **Locate Continuity Test Stations at every connection to existing water mains and every plug or cap fitting; see Standard Details W/9.0.**
- (4) **PVC Insulating Spool is allowed for 12-inch and smaller mains, if the operating pressure, pipe dimension ratio and allowable cover are within the limits allowed; see Standard Detail C/3.2a.**



**d. Determining Type of Pipe Material**

1) For determining pipe material to be used in design, see Chart "E".

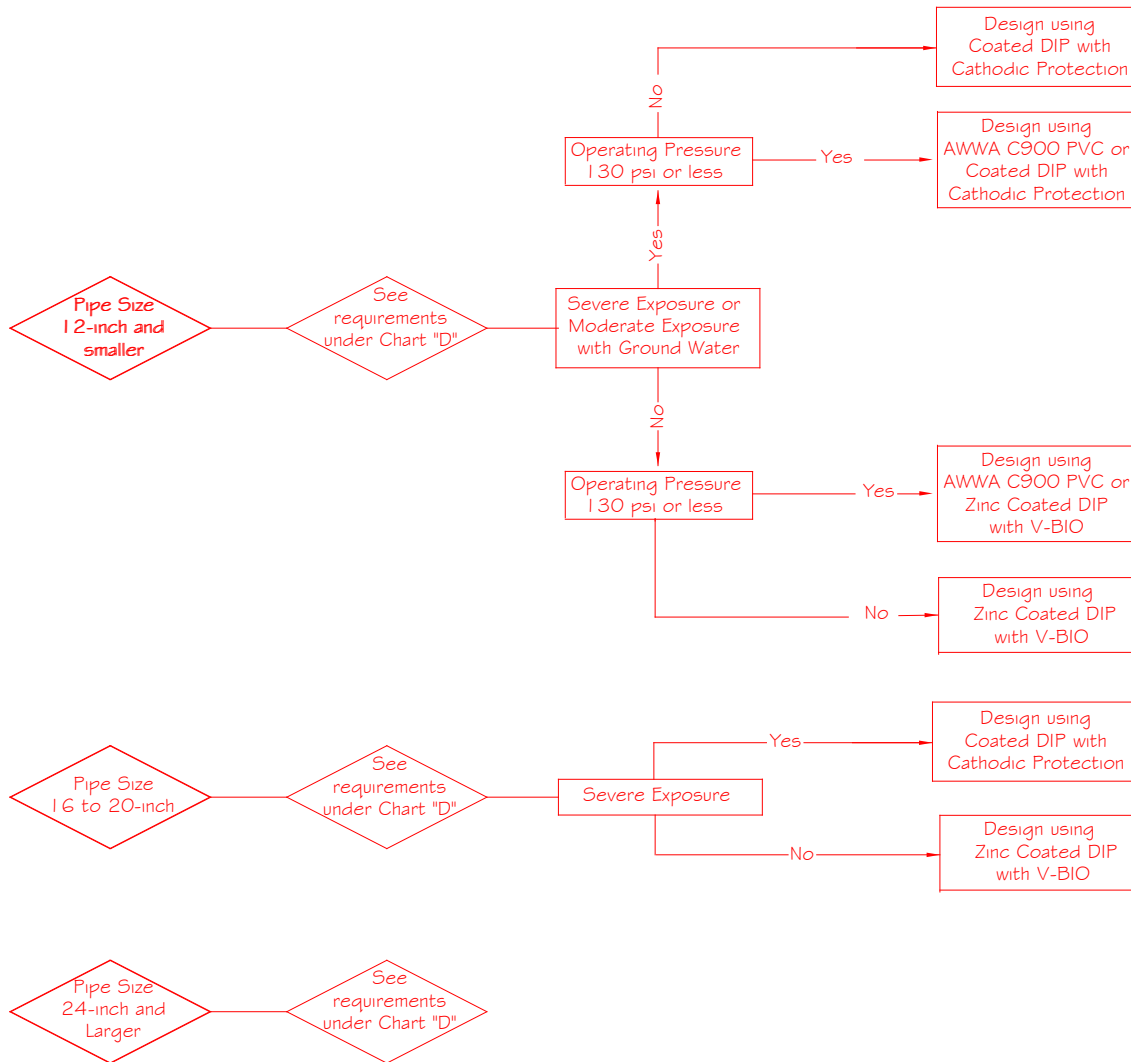

**NOTE:**

For Chart "D", see Part Three, Section 28, Corrosion Control

**CHART "E"**

Selection of Pipe Material

**e. Depth of Cover for DIP Greater Than WSSC Requirements.**



- 1) For depths of cover greater than shown in Standard Detail W/6.0, or for other special conditions, the wall thickness for DIP must be calculated in accordance with the method in AWWA Standard C150/ANSI A.21.50. Use the assumption of Laying Condition Type 1 for pipe sizes 24-inch and smaller and Laying Condition Type 3 for pipe sizes larger than 24-inch.
- 2) Based on the calculated thickness, select a class of pipe **greater than class 54**. The thickness of the selected class must be equal to, or greater than, the calculated thickness.

**f. Wall Thickness of DIP for Special Applications.**

- 1) Wall thickness criteria for DIP for the following special applications are not covered in the Standard Details and additional consideration/calculations are required in the following situations:
  - a) Pipe on supports or hangers, e.g. bridge crossings.
  - b) Shallow cover, less than two and one half (2-1/2) feet.
  - c) Vehicular or equipment loading greater than AASHTO H-20 or HS-20 loads configuration.
  - d) Operating pressures greater than those found in the WSSC's water distribution system.
  - e) Surges exceeding allowances given in the Specifications and under Part One, Section 5 (Total Internal and Transient Pressures).
  - f) Certain vacuum conditions; see Part One, Section 6 (Buckling Design).
  - g) When the pipeline crosses under a railroad, verify with the Railroad Authority, the requirements for crossing its property or right of way.
  - h) **When required under Part Three, Section 28 Corrosion Control.**
  - i) When pipelines are to be designed within MSHA right of way for highways, design the pipeline as follows:
    - (1) MSHA definition for types of highways (from MSHA Utility Policy, dated March 1998). Contact the MSHA for current guidelines.
      - (a) Expressways are divided highways, with full control of access, on which all crossroads are grade separations and all entrance and exit maneuvers are via interchange ramps. Expressways are primarily designed for high speed, long distance travel with unrestricted movement of traffic and no direct access to abutting properties.
      - (b) Controlled Access Highways are a higher class of highway and usually incorporate access control. Controlled access designations severely restrict the use of highway right of way for any purpose other than its primary function. Controlled access limits are denoted on MSHA drawings and plats by the words "Right of Way of Through Highway".
    - (2) Requirements stated below are only for pipelines within MSHA's right of ways and are only





- general guidelines. Verify additional requirements with MSHA.
- (a) Pipelines passing through MSHA's highways.
    - [1] All pipelines crossings must be in a sleeve, tunnel or have the class of DIP increased to the next higher class of pipe.
  - (b) Longitudinal occupancy by pipelines within MSHA's right of way for highways.
    - [1] Expressways. No longitudinal occupancy by new pipelines is permitted.
    - [2] Controlled Access Highways. Longitudinal occupancy is permitted by special exemption. During the design, obtain written exemption from MSHA.
    - [3] Roadways other than Expressways and Controlled Access Highways. Longitudinal occupancy is permitted; see MSHA Utility Policy, dated March 1998.
  - j) When pipelines are to be designed near or within Maryland Transit Administration (MTA) Rail Lines, see Part Three, Section 3 (Pipeline Crossings and Clearances) and Part Three, Section 26 (Tunnels Design Criteria).
  - g. When pipelines are to be designed near or within Marlboro Clay
    - 1) See requirements under Part 3, Section 19, Geotechnical Considerations for Crossing Pipeline Alignments.
    - 2) Design using DIP and restrain all joints at a minimum, see recommendations from Geotechnical Report.



## 5. Total Internal and Transient Pressures.

### a. Total Internal Pressure.

- 1) Determine total internal pressure for water mains from the following equation:

$$\text{Total Pressure} = \text{Operating Pressure} + \text{Surge Pressure}$$

- a) Operating Pressure is based on ductile iron pipe
- b) Surge pressure used by WSSC for ductile iron pipe.

(1) PVC AWWA C900.

- (a) The pipe can sustain a total working pressure based on an operating pressure of one-hundred and thirty (130) psi and a surge allowance based on normal surge pressure allowances used by WSSC for DIP, see Table "1". PVC may not be used if the operating pressure exceeds 130 psi.

### b. Operating Pressure.

- 1) The operating pressure (also referred to as the working pressure) of buried water pipelines is a function of the pipe elevation. Therefore, the operating pressure (and total pressure) varies at different elevations along the pipeline.

- a) Calculate the operating pressure using the following equation:

$$(\text{HHG in feet} - \text{pipe invert elevation in feet}) \times 0.433 = \text{Operating Pressure in lbs/in}^2$$

- 2) To determine the applicable HHG, the following is required:

- a) New Pipeline Designs, obtain the HHG and LHG from WSSC Planning Group.
- b) Existing Water Pipelines, the HHG used for the original design of the existing pipeline can be obtained typically from the lower left-hand corner or in the General Notes on the record (as-built) drawings. If the HHG is not indicated on the record drawings, then it may be obtained from WSSC. Prior to performing any new investigations or evaluations of existing water mains, verify with the WSSC if the HHG shown on the record drawings is applicable.



**c. Surge (Transient) Pressures.**

- 1) Use Table "1" for standard surge pressures for the design of water pipelines:

**TABLE "1"**  
Surge Pressures

Pipeline Diameter in inches	Surge Pressure in lb/in <sup>2</sup>	Pipeline Diameter in inches	Surge Pressure in lb/in <sup>2</sup>
4 to 10	120	30	80
12 to 14	110	36	75
16 to 18	100	42 to 60	70
20	90	Greater than 60	65
24	85	--	--

- 2) Assure that the design does not create conditions which will result in surge pressures greater than the values shown in Table "1", and no greater than the surge pressure allowances used for the design of adjacent pipelines.
- 3) Exercise sound judgement in determining whether a detailed surge analysis is necessary. Some conditions that may warrant the consideration of a surge analysis include the following:
- Impact of power failure, pump start up or quick closure of discharge valves at water pumping station or an in-line booster pumping station.
  - Possible impact due to water column separation.
  - Rapid closure of remotely controlled in-line valves.
  - Inadvertent, rapid closure of altitude valves at water storage tanks.
- 4) A detailed surge analysis may be performed using Bentley **Water Hammer and Transient Analysis Software** and **submit to WSSC for approval**. Consider the effects of line friction in the analysis. Consult with WSSC regarding any available surge studies and analysis that may have been performed for the study area **prior to beginning**. **For examples or more information contact WSSC Planning Group,**



## 6. Buckling Design.

### a. Criteria.

- 1) Check for buckling on steel pipe of all diameters and DIP greater than 24-inch in diameter and all sizes of DIP under some extreme conditions such as evacuation of pipe installed under water. Use the appropriate factor of safety from the referenced publication below and the following:
  - a) Assume vacuum pressure equal to 14.7 psi.
  - b) E' [Modulus of soil reaction] for soil shall be four hundred (400) psi.
  - c) Ground water level as indicated by soil borings and modified for expected fluctuation or may conservatively be taken at the ground surface unless the pipe is installed under water or in the flood plain (Use one hundred (100) year flood level).
  - d) Live load for AASHTO HS-20 truck and the numerical value as shown in the Table 1 of AWWA C150.
  - e) Deduct service allowance of 0.08 inch for DIP without cathodic protection and deduct the casting tolerance for all DIP as recommended by the pipe manufacturer for calculating the net thickness for buckling check.
  - f) See References below for method of computation.

### b. References.

- 1) Ductile Iron Pipe: "Critical Buckling Pressure for Ductile Iron Pipe". Ductile Iron Pipe Research Association, Technical Report, Richard W. Bonds, July 1, 1992.
- 2) Steel Pipe: "Steel Pipe - A Guide for Design and Installation", American Water Works Association, AWWA M-11.



## 7. Allowable Fittings.

### a. General Requirements.

- 1) The fittings listed in this section are generally the allowable fittings for the design of DIP and PVC pipe. For steel pipe and fittings, see Part One, Sections 2 (Pipe Material and Fittings) and 3 (Pipe and Fitting Joints).

### b. Design Considerations.

#### 1) DIP.

- a) Allowable fittings can be either AWWA C110 (full size fittings) or AWWA C153 (compact fittings). The lay lengths are different between the two AWWA standards. Determine if space requirements will limit the design to either AWWA C110 or C153 fittings.
- b) Compact fittings in accordance with AWWA C153. The lay lengths for these fittings are in accordance with AWWA C153, which only provides a minimum lay length for each fitting. Use the minimum lay length of the fitting, as specified in AWWA C153 and provide a means to adjust to the manufacturer's lay length in the design.
- c) Fittings for 54-inch DIP.

- (1) Lay lengths for these fittings are in accordance with AWWA C153, which only provides a minimum lay length for each fitting. Use the minimum lay length of the fitting, as specified in AWWA C153 and provide a means to adjust to the manufacturer's lay length in the design.
- (2) Mechanical joints are not available on fittings for 54-inch DIP, see Part One, Section 3 (Pipe Material and Fittings). Therefore, connections to field cut restrained joint 54-inch DIP can not be accomplished with a mechanical joint solid sleeve. Special attention will be required for the design in order to avoid the need for connecting to field-cut 54-inch restrained joint DIP pipe or provide some other means for closures (field welding of the retainers is not permitted).

#### d) ANSI B/16.1, Class 250 Flanges on Fittings.

- (1) Specify ANSI B16.1, Class 250 flanged fittings when they will be connected to a Class 250 Gate Valve, see requirements under Part One, Section 19 (Pipeline Valves). During the design, if possible try to use a transition short piece of DIP (ANSI B16.1, Class 250 flat face flange by AWWA C110 flange).
- (2) ANSI B16.1, Class 250 flanged fittings may not be available. Verify availability with the manufacturer during the design. ANSI B16.1, Class 250 requirements for lay lengths, which are different than AWWA C110 requirements. The design must incorporate the lay length that will allow all **approved** manufacturers to supply the fittings.

- 2) PVC Pipe. Ductile Iron fittings as specified in this section.



**c. Type of Fittings****1) Bends.**

- a) Minimize the use of bends and attempt to align the pipeline by deflecting pipe joints, see Part One, Section 12 (Allowable Joint Deflections). Deflecting the joints on bends is not permitted, see Part One, Section 14 (Joint Deflection at Fittings), unless thrust restraint design calculations for the bend for additional joint deflections are submitted in accordance with Part Three, Section 27 (Thrust Restraint Design For Buried Piping).
- b) Allowable bends
  - (1) For Ductile Iron Fittings,  $1/4^{\text{th}}$  or  $90^{\circ}$ ,  $1/8^{\text{th}}$  or  $45^{\circ}$ ,  $1/16^{\text{th}}$  or  $22-1/2^{\circ}$  and  $1/32^{\text{nd}}$  or  $11-1/4^{\circ}$ . Use of  $1/4^{\text{th}}$  or  $90^{\circ}$  bends in the horizontal plane only upon approval. Use of  $1/4^{\text{th}}$  or  $90^{\circ}$  bends is not permitted in the vertical plane.
- c) Bends can be used in the horizontal or vertical plane.
  - (1) Horizontal plane bends are referred to as horizontal bends (HB).
  - (2) Vertical plane bends are referred to as Upper Vertical Bend (UVB), where the thrust force is transferred upward to top of pipe and Lower Vertical Bend (LVB), where the thrust force is transferred downward to invert of pipe.
- d) Thrust blocking for bends or pipes greater than 16-inch in diameter are not covered by the Standard Details and requires special design; see Part Three, Section 27 (Thrust Restraint Design For Buried Piping).
- e) Bends designed to be rotated in both the horizontal and vertical plane require special pipe restraint; see Part One, Sections 13 (Rotation of Fittings), 14 (Joint Deflections at Fittings) and 15 (Deflections of Pipe Joints) and Part Three, Section 27 (Thrust Restraint Design For Buried Piping).

**2) Tees.**

- a) The connecting branch pipe must be perpendicular or ninety ( $90^{\circ}$ ) degrees to the mainline pipe. No joint deflections are allowed at the branch connection of the tee.
- b) If the mainline DIP is 24-inch or larger and it is noted on the drawings, a welded-on connection 8-inch and smaller may be designed in lieu of a tee, see Welded-on Connections, in this section.
- c) Use a TS&V when connecting to an existing main having more than ten (10) domestic services that would be placed out of service during the installation of a tee. Exceptions may be granted, if no other alignments are feasible.
- d) Thrust blocking for branch sizes larger than 16-inch diameter are not covered by the Standard Details and require special thrust restraint design; see Part Three, Section 27 (Thrust Restraint Design For Buried Piping).



- e) Tees designed to be rotated greater than five (5°) degrees in the vertical plane may require special pipe restraint; see Part Three, Section 27 (Thrust Restraint Design For Buried Piping) and Design Requirements for Pipeline Valves under Part One, Section 18 (Pipeline Valves).

### 3) Cross.

- a) The alignment requires two connecting pipelines to cross the main pipeline perpendicular to each other.
- b) Welded-on connections and TS&V cannot be used in lieu of crosses, unless the connections are spaced far enough apart. See requirements for Welded-on Connections and TS&V, in this section.
- c) **Design the branch connections of the cross as follows:**
  - (1) **Extend both side of the cross a minimum of fifty (50) from the cross.**
  - (2) If the branch connections are not extended for the distance noted above, use two (2) tees.
    - (a) Example: If one side of the cross is not extended, the cross will act similar to a tee and will require thrust blocking. When the pipeline is extended in the future, removing the blocking behind the tee, a total water system shutdown would be required due to removal of the blocking and the plug.
    - (b) If the design requires connections on both sides of the pipeline and a cross cannot be used, provide a minimum of ten (10) feet spacing between the centerline of the tees. **If the branch connection off the cross is sufficiently restrained on both sides of the cross, a minimum of five (5) feet spacing between the centerline of the tees will be allowed.**
  - d) If the alignment from the cross requires using one or more reducers on one or both sides of the cross, special pipe restraints are needed for any unbalanced forces due to the reducer; see Part Three, Section 27 (Thrust Restraint Design For Buried Piping).

### 4) Tapping, Sleeve and Valve (TS&V).

- a) Design TS&V for only DIP, CIP and PVC pipe. Indicate on the drawings the type of existing pipe to be tapped. This information is provided from the as-built drawings and/or WSSC's contract files.
- b) When designing a connection to an existing CIP water pipeline, research the original contract documents, or verify with WSSC to determine the type and outside diameter of the existing pipeline.
  - (1) Older CIP (Pit Cast Iron Pipe and Centrifugally Cast Iron Pipe) that was manufactured prior to and into the 1950's, can have an outside diameter (OD) that is equal to or greater than the OD of CIP or DIP produced from the 1960's to the present.
  - (2) As-built drawings and contract files can be checked to ascertain the existing pipe class or wall thickness, so that a compatible tapping sleeve and gasket can be identified and incorporated into the contract documents.



- (3) If the class or thickness of the pipeline cannot be determined or if a suitable tapping sleeve and gasket combination cannot be identified, the design must provide for one of the following:
- (a) Test pits will be required **during design** on the existing pipeline **to determine** the pipe OD.
  - (b) Design the connection using a tee, in lieu of a TS&V.
  - (c) **Require** the contractor to test pit **to determine** the pipe OD and provide the suitable tapping sleeve.
- c) When the existing pipe is 12-inch and larger DIP or CIP and the connecting pipe is 6-inch and larger, design the connection to the existing pipeline using a TS&V. **Exceptions maybe approved on a case by case basis.**
- d) Use a TS&V when connecting to an existing main, **when** more than ten (10) domestic services would be placed out of service during the installation of a tee. Exceptions may be granted by the WSSC if no other alignments are feasible.
- e) Pipeline being tapped may be the same size as the branch pipe, unless the proposed **branch** is larger than 14-inch. **See** the requirements for valve sizing in Part One, Section 18 (Pipeline Valves).
- f) Design the location of the tapping sleeve on DIP or CIP so that the centerline of the connecting pipeline is a minimum of five (5) feet from the face of any existing bell joints.
- g) Verify that adequate space is available to avoid conflict between existing utilities and the tapping machine. Check with the tapping machine manufacturers for space requirements.
- h) Restrain or block the TS&V's in the same manner as a tee.
- i) For additional requirements; see Tees in this section.
- 5) Tapping Assembly and Valve (TA&V).**
- a) Tapping Assembly and Valve (TA&V) is not allowed for connecting to existing PCCP water mains.
  - b) For connecting to existing PCCP water mains, see **Standard Detail W/13.0.**
  - c) Show the manufacturer's name and job number for the existing PCCP pipeline on the drawings for example, Lockjoint # PE-00-00. This information can be obtained from WSSC.
- 6) Welded-on Connections.**
- a) Welded-on connections may be used in lieu of tees on DIP for blowoffs, air valves and branch connections if the mainline pipe is 24-inch diameter or larger and the welded-on connection is a minimum of 3-inch diameter up to a maximum of 8-inch diameter. For additional requirements see Tees, in this section.
  - b) In accordance with the Specifications, there are two types of Welded-on Connections:





(1) Welded-on Bosses

- (a) This type of outlet has the socket welded onto the mainline pipe. When a flanged valve is required to connect to the flanged welded-on boss, a short piece of flanged by flanged DIP will be required.

(2) Welded-on Outlets

- (a) This type of outlet has a short length of DIP welded onto the mainline pipe.
- a) In accordance with the Specifications, welded-on connections require a minimum Class 54 DIP for the mainline pipe. Restrain or block the welded-on connections in the same manner as a tee.
- d) Provide a note on the plan and profile indicating the location of the welded-on connection and type of outlet joint connection.
- e) Pipe joints for welded-on connections shall be as follows:
- (1) Flanged as specified in AWWA C-110 or ANSI B16.1 Class 250, when in a vault.
  - (2) Mechanical joint or push-on restrained joint bell when buried.
- f) Locate welded-on connections on the mainline pipe as follows:

(1) Welded-on Connections on Flanged Pipe

- (a) The centerline of the outlet must be a minimum of one-half (1/2) the outlet diameter plus 14-inch from the inside edge of the flange; see Sketch "B".

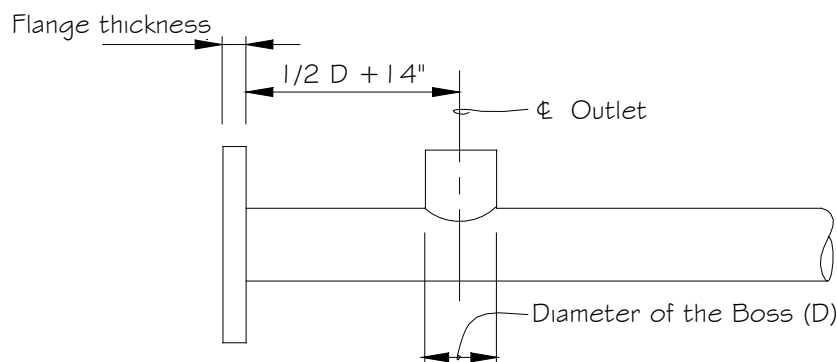

**SKETCH "B"**

*Location of Welded-on Connection, Flanged Pipe*

(2) Welded-on Connections on pipe other than flanged pipe

- (a) The centerline of the outlet must be a minimum of five (5) feet from the bell face of the mainline pipe; see Sketch "C":



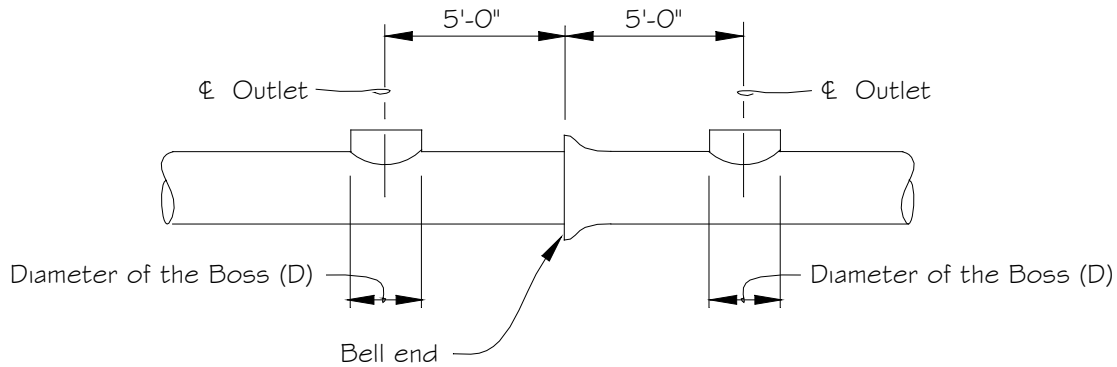

### SKETCH "C"

Location of Welded-on Connection,  
Pipe Other Than Flanged Pipe

#### 7) Plugs and Caps.

- a) Plugs and caps are to be used at the end of pipelines and branch connections. The Contractor has the option to use either a plug or cap.
- b) On the drawings specify a cap **or plug**.
- c) Thrust blocking for plugs and caps **or pipes** larger than 16-inch **in** diameter **are** not covered by the Standard Details and require special thrust restraint design; see Part Three, Section 27 (Thrust Restraint Design for Buried Piping).

#### 8) Wyes.

- a) Wyes are not permitted for use on water pipelines, except when the design requires flanged end fittings inside structures.

#### 9) Reducers.

- a) Required when downsizing the pipeline; may require special thrust restraint for unbalanced forces, see Part Three; Section 27 (Thrust Restraint Design for Buried Piping).
- b) Avoid using reducers on short runs of pipe if the cost of downsizing the pipeline, which includes pipe restraints for reducer, house connection taps with saddles, a reducer, etc., exceeds the cost of the larger diameter pipeline.
- c) When reducing the pipe size on 16-inch and larger pipelines, the profile must be examined to determine if the reducer will create a high point at the large end of the reducer. If so, use an eccentric reducer, matching the top elevations of both size pipelines at the reducer.

#### 10) Adapters.

- a) When connecting to or extending PCCP pipelines, a PCCP by DIP adapter is required; see Specifications for requirements of PCCP **by DIP** adapter.



- b) Typically, the DIP end of the adapter will require a flanged end; see Standard Details C/3.3 and C/3.4, and Part Three, Section 28 (Corrosion Control). When a PVC spool piece is used, the DIP end of the adapter will require a mechanical joint bell; see Standard Detail C/3.3a and Part Two, Section 3 (Pipe and Fitting Joints).
- c) Design the connection between PCCP and DIP to account for unbalanced thrusts. For requirements see Unbalanced Thrusts at Connections to Existing Water Pipelines under Part Three, Section 27 (Thrust Restraint Design for Buried Piping).

#### 11) Solid Sleeves and Mechanical Couplings.

- a) Generally, mechanical joint solid sleeves are used for direct burial conditions and mechanical couplings are used in vaults and structures.
- b) Type of DI mechanical joint solid sleeves is as follows:
  - (1) Mechanical Joint, Long Type
    - (a) Use this type of sleeve only for single closures between the ends of the pipeline.
    - (b) Typically this type of sleeve requires a spacer piece; see Standard detail W/11.0, for long type solid sleeves.
  - (2) Mechanical Joint, Short Type can be used as follows:
    - (a) Use two closures between the ends of the pipeline (which eliminates the need for a spacer piece); see Standard detail W/11.0.
    - (b) This type of sleeve may be an acceptable alternative to using a restrained mechanical coupling in a vault, in accordance with Standard Detail B/3.0, except the joints must be restrained with a wedge action restraining gland; see Standard Detail W/2.4 for an example.
    - (c) When using this fitting on situations other than those described above, **WSSC approval** will be required.
    - (d) Some manufacturers may not supply short type solid sleeves. The Designer must verify the availability of this fitting during the design.
  - (3) Solid Sleeve for 54-inch DIP.
    - (a) This type of sleeve is not available. During the design phase determine and verify the type of sleeve/coupling that will be required. See "Design Considerations" in this section for information on 54-inch diameter fittings.
- d) Types of mechanical couplings.
  - (1) Mechanical Couplings.
    - (a) Mechanical Couplings are used for connecting pipelines in vaults and structures where the pipelines have the same OD.



- (b) Direct burial of mechanical couplings requires WSSC approval and special exterior coatings, see Part Three, Section 28 (Corrosion Control).
- (c) Mechanical coupling may require restraint; see Standard Detail B/3.0.
- (d) When the design requires a mechanical coupling to be connected next to a flanged gate valve, provide a flanged spool piece a minimum of 12-inches long between the flanged end of the valve and the flanged end of the assembly for harnessing the coupling, see Standard Detail B/3.0.

(2) Transition Couplings.

- (a) Transition Couplings are used for connecting pipelines with different OD's. Verify OD's of the connecting pipes before specifying this type of coupling, or provide requirements in the contract documents for the contractor to verify the OD's.
- (b) For connecting to Existing Asbestos Cement Pipe (ACP), see Standard Detail W/11.1.
- (c) Transition Couplings may be used for direct burial with approval and require special exterior coatings, see Part Three, Section 28 (Corrosion Control).

(3) Insulating Couplings.

- (a) Insulating Couplings provide electrical isolation for metallic pipelines; see Part Three, Section 28 (Corrosion Control).
- (b) Direct burial of insulating couplings requires WSSC approval and special exterior coatings, see Part Three, Section 28 (Corrosion Control).
- (c) Use of insulating couplings requires special insulating thrust restraint if used on a restrained length of pipe.

**12) Other Fittings.**

- a) The allowable fittings listed in this section are the only fittings approved for design. Fitting manufacturers can produce non-AWWA standard fittings (AWWA C110, C153) which are not approved by WSSC. These fittings may be used in the design only with WSSC approval and require special provisions to the Specifications.



## 8. Horizontal Alignment.

### a. General.

- 1) The Designer has the responsibility to point out where various factors of good planning and design are in conflict with these guidelines and the requirements of other agencies. The alignment must be the best overall design. Failure to point out conflicts at an early stage in the design may result in delays and possibly costly changes.
- 2) If the design follows the guidelines in this manual, the design will most likely result in a plan that can be carried through to completion without delay.

### b. Considerations.

- 1) Identify and locate all existing **and** proposed facilities before selecting the location of the pipeline.
- 2) Consider the guidance in Part Three, Section 19 (Geotechnical Considerations for Pipeline Alignments), when selecting the horizontal alignment.

### c. Location.

- 1) The horizontal alignment shall take into account the following general alignment guidelines, if practical. Pipelines larger than 12-inch in diameter may have other limitations and requirements that alter these general alignment guidelines.
  - a) Where practical, design the **location of** water pipeline as follows:
    - (1) For paving with twenty-four (24) feet and wider design seven (7) feet from the centerline road.
    - (2) For paving width less with twenty-four (24) feet, design five (5) feet from the centerline road.
    - (3) Avoid locating pipeline in High Volume Roadways if possible. If required, locate pipeline to have only one-lane closure.
    - (4) Locate pipeline within the **existing or proposed** pavement of proposed streets
  - b) Locate the water pipeline on the higher elevation side of the street. Typically the sewer pipeline is located on the lower elevation side; see Part Two, Section 5 (General Horizontal Alignment) for locating sewer pipelines.
  - c) The pipeline alignment within existing areas (streets or roads) should avoid construction in high traffic volume roads **and avoid** road closings **if possible**.
  - d) In existing areas (streets or roads) the alignment of the pipeline should try to avoid the removal of trees or landscaped areas.
  - e) The pipeline alignment should be extended past the limits of the proposed road improvements



so that future pipeline extensions maybe constructed without the need to cut the pavement, **if possible.**

- f) When the pipeline alignment is located outside the road right of way, minimize disruption to environmental features and where possible avoid steep slopes, wetland areas, trees and other sensitive areas. Locate the alignment so that it follows the property lines as much as possible.
- h) Provide acceptable horizontal clearances for the proposed alignments where the existing mains are to remain in service. See Part Three, Section 3 (Pipeline Crossings and Clearances).
  - (1) Horizontal clearances between the existing and proposed pipelines may have to be increased when the pipeline is within the zone of influence of existing concrete blocking. To determine if there is adequate passive soil resistance, see Passive Soil Pressure for Concrete Thrust Blocks in Part Three, Section 27 (Thrust Restraint Design for Buried Piping).
  - i) When the existing or proposed pipelines will be installed in a casing pipe, no pipe deflections or fittings will be allowed in the casing pipe, see Part One, Section 18 (Tunnels or Casing Pipes).
  - j) For stream crossings, design the pipeline to be perpendicular to the stream crossing.

#### **d. Looping Water Systems**

- 1) WSSC has three (3) types of redundancy for water outages:
  - a) Water interconnections, which are hydraulically required system improvements resulting from increased demand loads (domestic and fire flow).
  - b) Domestic outage protection loops, which are built to provide a second feed for domestic water short-term outages of water services.
  - c) Transmission main outage protection loops, are loops for ensuring outage-protection (domestic and fire flow) when large-diameter water transmission mains made of PCCP are undergoing periodic maintenance, repair, and/or inspection. See Part One, Section 9 (Connections to Existing or Proposed Water Pipelines)
- 2) WSSC will determine when these types of looping water systems will be required.

#### **e. Labeling Pipeline in Plan.**

- 1) Label all pipe sizes, fittings and appurtenances for pipelines.
- 2) Label horizontal stations for all fittings and appurtenances on pipelines 16-inch and larger in diameter.
- 3) For both existing and proposed pipelines 24-inch and larger, show the pipeline in plan view as a double line with the centerline.
- 4) Show hundred-foot stations along the pipeline alignment in plan view.



- 5) Compare pipe sizes, fittings and appurtenances on the plan views with the profiles to avoid mislabeling.
- 6) Indicate the pipe class designation and pipe material in General Notes; see Part One, Section 4 (Selection of Pipe Material).



## 9. Connections to Existing or Proposed Water Pipelines.

### a. Design of Connections to Existing Pipelines.

#### 1) Limitation to connections to Existing Pipelines.

- a) Service Mains (12-inch and smaller) cannot connect to PCCP Transmission Mains 36-inch and larger, except in the following conditions; If the connection is to an existing PCCP water main and the proposed service connection is looped to another water main that is not depended on an existing the PCCP water main.

#### 2) Determine the pipe material and the alignment of the existing pipeline.

- a) Information that is available and items that is required to be developed.

- (1) WSSC "as-built" contract drawings are intended to show only the control reference ties to the horizontal appurtenances of the pipeline alignment, the type of pipe material used, and the Contractor's name. **The Designer shall assume that the as-builts do not always show changes to the original design alignment (horizontal or vertical) that may have been made during the construction of the pipeline.** The Designer must investigate using other methods described below and determine if any changes have been made to the original design of the existing pipeline, and adjust the design accordingly.

- (2) Field surveys must follow the requirements set by WSSC. Perform all surveys required to design the alignment. Any survey information that is provided by WSSC from previous contracts, etc., must be verified, as WSSC will not be responsible for this information.

- (3) Test pits are typically needed when the design requires the vertical and horizontal alignment to be accurately located. Perform test pits on the existing alignment so that the horizontal and vertical position can be accurately determined.

- (4) WSSC Contract Files may be requested by the Designer. The type of information that may be available in the contract files includes:

- (a) WSSC Construction Inspector's field reports/notes.

- (b) WSSC/Contractor written correspondence.

- (c) Contractor's shop drawings, including lay schedules for PCCP, etc.

#### 3) Connecting to existing pipelines other than DIP, CIP or PVC.

- a) Prestressed Concrete Cylinder Pipe (PCCP). Any connections between existing PCCP and new DIP will require special design including: Adapter (PCCP to DIP) see Part One, Section 7 (Allowable Fittings), Insulated Joint (typically flanged type) see Part One, Section 3 (Pipe and Fitting Joints), possible cathodic protection and special coatings see Part Three, Section 28 (Corrosion Control), and possible thrust restraint see Part Three, Section 27 (Thrust Restraint for Buried Piping). Verify the following for PCCP connections:





- (1) WSSC has installed Internal Acoustic fiber optic (AFO) Cables in most of the existing PCCP water pipeline. This cable is designed to monitor the existing condition of the PCCP pipeline.
  - (a) When connecting to existing PCCP pipelines, verify if the pipeline has AFO Cables. If pipeline has AFO Cables, the cables must be removed and replaced at no cost to WSSC as part of construction contract.
- (2) Perform test pits to verify the actual horizontal/vertical alignment of the existing PCCP pipeline, location of the existing joint, and to determine if the existing joint is beveled or straight.
- (3) If the existing PCCP has restrained joints, indicate this on the drawings and design the proposed connection to account for the restrained thrust.
- b) Steel Pipe, Asbestos Cement Pipe (ACP), old pit-cast CIP with oversize OD's. When the existing pipe material is not DIP, CIP or PCCP provide a detailed design and specifications on how the connection will be constructed.
  - (1) When connecting to existing ACP, design the connection to remove only a short section of existing ACP pipe. Existing ACP section replaced during the connection will remain in the trench, see Specifications.
- 4) Tapping existing pipelines requires test pits when certain physical features may prevent proper tapping of the existing pipe and when necessary to determine the alignment of the existing pipeline and the location of the existing pipe joints. For information on positioning a TS&V on DIP, CIP or PVC, see Part One, Section 7 (Allowable Fittings).
  - (1) Tapping PCCP water mains is not allowed; see Part One, Section 7 (Allowable Fittings).

**b. Revising Designed Connections During Construction.**

- 1) Connecting to an existing pipeline 12-inch and smaller in diameter. The vertical and horizontal alignment can usually be changed or revised during construction of the pipelines with little difficulty due to the amount of allowable joint deflection, which provides greater alignment flexibility.
- 2) Connecting to an existing pipeline 16-inch and larger in diameter. The vertical and horizontal alignment may require additional fittings, appurtenances and etc., to adjust alignment location during construction.
  - (a) If the vertical alignment requires revisions, the new alignment may create additional high or low points. In this case, additional blow-off connections or air release valves may be required.
  - (b) If the vertical and horizontal alignment both requires revisions, the new alignment may result in pipeline joints having deflections exceeding the allowable deflections, which would require additional bends and thrust restraints to be added.



**c. Connection to Proposed or Future Pipelines.**

- 1) **When connecting to a pipeline to be built under another contract;**
  - (a) **The designer is responsible for investigation and coordinating work within the same design area.**
  - (b) **When connecting to existing pipeline, show at least two hundred (200) feet pass the connection point.**
  - (c) When the pipeline under design will be extended, design the future alignment approximately two-hundred (200) feet from the end of the cap or plug and, see requirements under Length of Profile, Part One, Section 11 (Vertical Alignment – Profiles).
  - (d) If the new pipeline will depend on the construction of another pipeline for the supply of water, include a “Dependency Note” on the drawings. Indicate in the note that the new pipeline cannot be placed in service until another contract is in service; provide contract numbers of the depending pipeline.

**d. Labeling Existing Pipelines on the Drawings.**

- 1) Existing pipeline material (DIP, CIP, PVC, PCCP, ACP, steel, etc.), thickness class, type, grade, etc. For PCCP, indicate the manufacturer's name and job number for the existing PCCP pipeline.
- 2) Existing WSSC contract number.
- 3) Special pipe corrosion protection, coatings, wrappings, joint bonding, etc.
- 4) Special thrust restraint, existing special thrust blocking and/or existing restrained joint types, locations and lengths, including valves restrained to tees.

**e. Special Items.**

- 1) Special items to be considered during the design of connections to existing pipelines include thrust pipe restraints, see Part Three, Section 27 (Thrust Restraint Design for Buried Piping) and pipe corrosion protection; see Part Three, Section 28 (Corrosion Control).
- 2) When shutdown of the existing water system is determined to be impossible, line stops can be **added to the** design to temporarily shut down the existing water pipeline. See Specifications for requirements and Part One, Section 22 (Specialty Valves). Special thrust pipe restraints will be required to restrain the line stop, see Part Three, Section 27 (Thrust Restraint Design for Buried Piping).



## 10. Relocating Water Pipelines.

### a. General.

- 1) Take into account such matters as environmental impact, maintenance of pedestrian and vehicular traffic flow, maintenance of existing and proposed utility services, constructability, permit restrictions, and maintenance, and produce the overall most cost-effective design.
- 2) When the existing ground condition change due to grading, roadways, railways or etc. the existing water pipeline will have to be evaluated by WSSC Technical Services Group.
- 3) When another agency, utility, etc. is modifying the conditions over WSSC existing water pipeline and appurtenances, WSSC will have to review and approved such changes and may require the existing water pipeline and appurtenances to be relocated.

### b. Alignment - Horizontal and Vertical.

- 1) The impact on all existing and proposed facilities shall be taken into consideration before selecting the alignment for the relocated pipeline.
- 2) Contact the WSSC for limitations on shutdowns of existing pipelines.
- 3) When selecting an alignment, the existing pipeline must be maintained and remain in service until the relocated pipeline is ready for final connection to the existing main. At that time, the existing pipeline will be shut down and all tie-ins between the existing pipeline and the relocated pipeline can be performed, including the transfer of water house connections.
  - a) If all the re-connections and transfer of all the water house connections cannot be made during a normal 8 hour shutdown time frame, the design must include having both the existing pipeline and relocated pipeline in service at the same time. This may be accomplished by temporarily plugging and blocking opposite ends of both the existing pipeline and the relocated pipeline, and leaving the other end in service. During this time, all the connections can be transferred and then final connections can be performed.
- 4) Relocating pipeline along the same alignment (same trench). When the existing pipeline must be replaced in the same location/alignment, take into account the limitations for shutdown and the constructability of the alignment. The design will require temporary pipe restraint, removal of the existing pipeline, installation of temporary water service to existing customers, and a long shutdown period.
- 5) Locate all the existing services and appurtenances (water house connections, valves, fire hydrants, blowoffs, air valves, etc..) that are connected to the existing pipeline.
- 6) For information on the design and location of structures and appurtenances, see Part One, Section 16 (Design of Structures) and Part Three, Section 17 (Evaluation of Existing Pipeline Structures).
- 7) For requirements on reconnecting the relocated pipeline see Part One, Section 9 (Connections to Existing or Proposed Water Pipelines).



- 8) Ensure acceptable horizontal clearances for relocated alignments where the existing mains are to remain in service until the relocation is complete.
  - a) Spacing between the existing and relocated water pipelines shall be as described in Part One, Section 8 (Horizontal Alignment) and Part Three, Section 3 (Pipeline Crossings and Clearances).
  - b) Horizontal clearances between the existing and relocated pipelines may have to be increased when the relocated pipeline is within the zone of influence of existing concrete blocking. To determine if there is adequate passive soil resistance, see Passive Soil Pressure for Concrete Thrust Blocks in Part Three, Section 27 (Thrust Restraint Design for Buried Piping).
- 9) Vertical clearances for relocated alignments must maintain a minimum of one (1) foot clearance between pipe OD's (including the existing pipeline that will be abandoned by the relocation). **For additional information, see Part Three, Section 3 (Pipeline Crossing and Clearances)**

**c. Thrust Restraint.**

- 1) The design of the relocated alignment must not disturb existing blocking/thrust restraints on existing pipelines that are in service.
- 2) Provide thrust restraints for the relocated pipeline. If the shutdown time is limited, the design will require a thrust block for quick connections for restraining the relocated pipeline, so that WSSC's customers are not out of water service for an extended period, see Part Three, Section 27 (Thrust Restraint Design for Buried Piping).

**d. Abandonment.**

- 1) Show on the drawings any abandonment of existing pipelines, structures and/or appurtenances. Indicate the limits of abandonment and provide a description and sequence of what will be abandoned. The description shall also include the abandonment that will be performed, see requirements in Specifications and Part Three, Section 5 (Pipeline Abandonment).



## 11. Vertical Alignment (Profiles).

### a. Cover Over Pipeline.

- 1) Minimum cover over the top of the pipe: four (4) feet from the lowest profile grade or ground line.
- 2) Pipelines crossing under a stream (water crossings), channels and ditches.
  - a) For dry ditches and concrete channels:
    - (1) Provide a minimum four (4) feet cover over the top of the pipe.
    - (2) If the design requires less than four (4) feet of cover, submit the design along with calculations for special pipe and trench protection, see Part One, Section 4 (Selection of Pipe Material).
    - (3) If the crossing is located under a concrete channel measuring ten (10) foot or more from top of channel to top of channel, then install the water pipeline in a casing pipe, see Part One, Section 17 (Tunnels and Casing Pipes)
  - b) Stream (water crossings):
    - (1) Provide a minimum five (5) feet cover over the top of the pipe.
    - (2) If the stream (water crossings) is greater than fifteen (15) feet deep (top of high bank to top of pipe) provide the following:
      - (a) Restrain all joints a minimum of one hundred (100) feet from edge of bank; if fittings are located within this area, see Part Three, Section 27 (Thrust Restraint Design for Buried Piping).
      - (b) Provide valves on both ends of the crossing. Valves must be accessible and not located in the One hundred (100) Year Flood Area
      - (c) Align the crossing perpendicular to the stream to the extent practical.
  - c) Show invert/bottom elevation of the crossing stream, ditch, etc on the profile.
  - d) Do not locate pipe fittings and structures within five (5) feet horizontal of the limits of the stream, ditch, etc., between edges of the top of high banks.
  - e) For additional requirements for stream crossings, see Part Three, Section 9 (Pipeline Stream Crossings).
- 3) Pipeline clearances with other pipelines and utilities; see Part Three, Section 3 (Pipeline Crossings and Clearances).



**b. Labeling Pipeline in Profile.**

- 1) Label all pipe sizes, fittings and appurtenances, and provide stations and invert elevations as required in this section.
- 2) Indicate the class of DIP or PVC as required under Part One, Section 2 (Pipeline Materials and Fittings) and Section 4 (Selection of Pipe Material). Provide stations on the profile to show the limits and class of DIP or PVC for all areas, including those which require a pipe class higher than the minimum class.
- 3) Show the direction of thrust for all thrust collar blocks and show the concrete thrust block location, see Standard Details B/3.1 and B/3.3, and Part Three, Section 27 (Thrust Restraint Design for Buried Piping). If the design has restrained joints, provide stationing showing the limits of the restrained joints.

**c. Change in Vertical Alignment.**

- 1) Except for vertical bends, design the pipeline using vertical joint deflections. Provide stations and elevations based on twenty (20) foot lay lengths. Do not exceed the maximum allowable joint deflections as shown in the tables under Part One, Section 12 (Allowable Joint Deflections).
- 2) When joint deflections used in the horizontal plane are at the maximum allowable **deflection**, no vertical deflection may be used. When joint deflections are used in both the horizontal and vertical plane, do not exceed the maximum allowable joint deflection; see requirements in Part One, Section 12 (Allowable Joint Deflections) and Section 15 (Deflection of Pipe Joints).

**d. Stations and Elevations.**

- 1) Pipelines smaller than 24-inch diameter, the pipeline can be shown in profiles with curves. Show the stations and elevations at fifty (50) foot intervals.
- 2) Pipelines 24-inch diameter and larger, do not show the pipeline on profile with curved lines, only show a series of straight lines with deflections. Base the deflections on twenty (20) foot intervals of pipe with stations and elevations given at each deflection. When the pipeline has no deflections, give stations and elevations at fifty (50) foot intervals.
- 3) Provide stations and elevations at every pipeline **and** utility crossing and at every high/low point.
- 4) **P** Provide the type of fitting, station and elevation **at all fitting locations**.

**e. Design of Structures on Profile.**

- 1) Verify that the vertical depth (invert) of the pipeline is set at the proper depth of the structure.



**f. Profile Grade Lines.**

- 1) Pipelines within or adjacent to a roadway.
  - a) On Existing roadways show the following:
    - (1) Centerline of Existing Paving from field surveys.
    - (2) Existing Ground over Centerline of Pipeline from field surveys. If the ground elevation differs by one (1) foot or more, show both the centerline of existing paving and the existing ground over centerline of pipeline.
    - (3) Existing Established Centerline Roadway Grade from approved street grade drawing.
    - (4) If the roadway does not have an established roadway grade, provide the following:
      - (a) Contact the agencies having jurisdiction over the existing roadway and submit for approval all necessary designs and drawings. Show the established roadway grade on profile, labeling it, Established Centerline Roadway Grade.
      - (b) At the option of WSSC, show only the design of the roadway improvements on profile and label it "Possible Future Centerline of Roadway or Possible Future Grade".
  - b) New or proposed roadways show the following:
    - (1) Centerline of Finished Roadway Grade.
    - (2) Finished Grade over Centerline of Pipeline, if the grade elevation differs by one (1) foot or more show both the centerline of finished roadway grade and the finished grade over centerline of pipeline.
    - (3) Finished Grade is the proposed elevation over the pipeline during or after pipeline construction.
- 2) Pipelines not within or adjacent to a roadway (across property), show Existing Ground over Centerline of Pipeline and Finished Grade over Centerline of Pipeline.
- 3) Pipelines running parallel to an existing or proposed ditch, streams, etc. and within ten (10) feet of the bank or slope show the invert (bottom) elevation of the ditch, stream, etc. on the profile.
- 4) Indicate the grade/ground lines on the profile as follows:
  - a) Centerline of existing roadway - solid line.
  - b) Established or possible future centerline of roadway - dashed line.
  - c) Existing ground or grade over centerline of pipeline - solid "freehand" line.
  - d) Proposed grade over centerline of pipeline - dashed "freehand" line.



**g. Length of Profile.**

- 1) Show the grade or ground lines for the entire length of the pipeline.
- 2) When connecting to existing mains or ending the pipeline, show an additional two hundred (200) feet of the following:
  - a) Existing and proposed grade or ground lines and the existing pipeline extending from the new pipeline or past the limits of the new pipeline when ending with a cap/plug.
  - b) Sufficient future extensions of the pipeline design must be shown to assure proper depth of the alignment. The amount of additional length will be determined on a case by case basis.
- 3) When beginning or ending the pipeline with a tee, show approximately one hundred (100) feet of the grade/ground line past the limits of the branch connection.

**h. Pipeline Stationing.**

- 1) Measure the pipeline stations along centerline of the pipeline in the horizontal plane.
- 2) Pipelines within or adjacent to a roadway.
  - a) Pipelines 12-inch and smaller, horizontal stations on the baseline of the profile represent the centerline of the roadway with the location of the pipeline stationing projected on to the centerline of the roadway. This means that the horizontal distances on the pipeline alignment cannot be scaled accurately on the profiles where they are not entirely parallel and straight with the centerline of the roadway. However, show the pipeline stations as they are actually measured horizontally along the pipeline on the profile.
  - b) Pipelines 16-inch and larger, horizontal stations on the profile represent the centerline stationing along the pipeline with the centerline of the roadway projected on the pipeline centerline. In cases where other utilities will be shown on the profile, the location shall be projected on the water pipeline centerline.
- 3) Pipelines not within or adjacent to roadway (across property); the horizontal stations on the profile represent the centerline stationing along the pipeline.





## 12. Allowable Joint Deflections.

### a. General.

- 1) When it is necessary to deflect pipe from a straight line in either the horizontal or vertical plane, the amount of joint deflection shall not exceed the allowable joint deflections as shown in Tables "3", "3.1", "4", "5.0", "5.0a", "5.1", "5.2", "5.3" and "5.4". Figure "A" illustrates the joint deflections shown in the tables. The deflections listed in the tables are the maximum deflections allowable for WSSC pipeline designs and should not be exceeded. Assume twenty (20) foot lengths of pipe for design purposes.

### b. DIP and PVC with Push-on Type Joints.

- 1) For maximum joint deflections for full-length DIP with push-on type joints, see Table "3". The maximum deflection angles shown in Table "3" are used for design purposes and are based on eighty (80%) percent of the maximum recommended deflection for standard pipe joints that all DIP manufacturers can produce. The eighty (80%) percent value is based on AWWA C600 recommendations.
- 2) DIP manufacturers can produce pipe with larger joint deflections or special pipe joints with larger deflections. If the design requires larger deflections than those shown in Table "3", submit information for approval.

**TABLE "3"**

Deflection Table - DIP Push-on Type Joints

Nominal Pipe Size Diameter (D)	Maximum Offset Based on 20 Foot Lengths of Pipe (S)	Design Maximum Deflection Angle ( $\Theta$ )	Minimum Allowable Radius (R)
12-inch and under	1.39 feet	04°-00' (4.0°)	290 feet
14-inch and over	0.83 feet	02°-24' (2.4°)	480 feet

- 3) For maximum joint deflections for full-length PVC pipe with push-on type joints on pipelines which are 12-inches and smaller in diameter, see Table "3.1". The maximum deflection angle in Table "3.1" is used for design and is based on seventy (70%) percent of the recommended deflection for standard pipe joints that most PVC manufacturers can produce.
- 4) No deflection at connection to DIP or at fittings.
- 5) Only pipe joint deflections are allowed at joint, no bending of the pipe.

**TABLE "3.1"**

Deflection Table - PVC Pipe with Push-on Joints

Nominal Pipe Size Diameter (D)	Maximum Offset Based on 20 Foot Lengths of Pipe (S)	Design Maximum Deflection Angle ( $\Theta$ )	Minimum Allowable Radius (R)
12-inch and under	0.48 feet	01°-24' (1.4°)	820 feet



**c. DIP Mechanical Joints.**

- 1) For maximum joint deflections on full-length DIP mechanical joint pipe, see Table "4". The maximum deflection angle in Table "4" is used for design purposes and is based on eighty (80%) percent of the maximum recommended deflection set by WSSC for pipe sizes 20-inch and smaller and on AWWA C600 for 24-inch pipe. The eighty (80%) percent value is based on AWWA C600 recommendations.
- 2) Mechanical joint pipe may not be available, therefore verify the availability of Mechanical Joint Pipe with the pipe manufacturers before specifying this type of pipe in the design.

**TABLE "4"**

Deflection Table - DIP Mechanical Joint Pipe

Nominal Pipe Size Diameter (D)	Maximum Offset Based on 20 Foot Lengths of Pipe (S)	Design Maximum Deflection Angle (Θ)	Minimum Allowable Radius (R)
12-inch and under	1.39 feet	04°-00' (4.0°)	290 feet
14-inch to 20-inch	0.83 feet	02°-24' (2.4°)	480 feet
24-inch	0.56 feet	01°-36' (1.6°)	720 feet

**d. Restrained Joint Pipe.**

- 1) For maximum joint deflections on full length restrained joint DIP or PVC pipe, see Tables "5.0", "5.0a", "5.1", "5.2", "5.3" and "5.4".
- 2) The types of restrained joint pipe and fittings in the tables below are the WSSC approved restrained joints (pipe or fittings) which are included in the Standard Details and the Specifications. First consider using concrete thrust blocking before specifying restrained joints, see Part Three, Section 27 (Thrust Restraint Design for Buried Piping).
- 3) Indicate on the drawings the limits of restrained joints in the Blocking Notes and on the profile.
- 4) Type of restrained joints:
  - a) Wedge action-restraining glands on DIP mechanical joint pipe.
    - (1) For maximum joint deflections for full length restrained mechanical joint pipe with wedge action restraining glands, see Table "5.0". The maximum deflection angle in Table "5.0" is used for design purposes, and is based on eighty percent (80%) of the maximum recommended deflection set by WSSC for pipe sizes 20-inch and smaller and on AWWA C-600 for 24-inch diameter pipe.
    - (2) Maximum size of wedge action restraining glands for fittings is 48-inch diameter. Mechanical joint pipe is only available in pipe sizes 24-inch and smaller diameter, therefore verify the availability of 14-inch to 24-inch Mechanical Joint Pipe with the mechanical joint pipe manufacturers before specifying in the design.
    - (3) Only use wedge action restraining glands when the total pressure (operating pressure plus



surge pressure) is below the pressures in Table "5.0a".

- (4) **For Wedge action restraining glands, see Standard Detail B/2.7. Do not design wedge action restraining glands on existing CIP pipelines.**

**TABLE "5.0"**

Deflection Table - Wedge Action Restraining Glands - Mechanical Joint DIP

Nominal Pipe Size Diameter (D)	Maximum Offset Based on 20 Foot Lengths of Pipe (S)	Design Maximum Deflection Angle ( $\Theta$ )	Minimum Allowable Radius (R)
12-inch and under	1.39 feet	04°-00' (4.0°)	290 feet
14-inch to 20-inch	0.83 feet	02°-24' (2.4°)	480 feet
24-inch	0.56 feet	01°-36' (1.6°)	720 feet

**TABLE "5.0a"**

Maximum Total Pressure for Wedge Action Restraining Glands for DIP

Nominal Pipe Size Diameter (D)	Total Pressure (Operating Pressure plus Surge Pressure)
16-inch and smaller	350 psi
Larger than 16-inch	250 psi

- b) Push-on restrained joint gaskets for DIP, 24-inch and smaller diameter.

- (1) Maximum joint deflections for full-length manufacturer's proprietary restrained joint DIP, see Table "5.1". Maximum deflection angle for design is based on eighty (80%) percent of the maximum recommended deflection angle set by WSSC for pipe sizes 24-inch and smaller in diameter.

**TABLE "5.1"**

Deflection Table - Manufacturer's Proprietary Restrained Joint DIP - Push-on Restrained Joint Gaskets

Nominal Pipe Size Diameter (D)	Maximum Offset Based on 20 Foot Lengths of Pipe (S)	Design Maximum Deflection Angle ( $\Theta$ )	Minimum Allowable Radius (R)
12-inch and under	1.39 feet	04°-00' (4.0°)	290 feet
14-inch to 24-inch	0.83 feet	02°-24' (2.4°)	480 feet

- c) Manufacturer's proprietary restrained joints for DIP, 14-inch and larger diameter.

- (1) For maximum joint deflections for full-length manufacturer's proprietary restrained joint DIP, see Table "5.2". The maximum deflection angle in Table "5.2" is used for design purposes and is based on eighty (80%) percent of the manufacturer's recommended deflection angle.
- (2) Manufacturers produce other types of restrained pipe and fittings, which are not included in the Specifications and Standard Details. These restrained joints may be specified if **submitted to WSSC for approval.**



**TABLE "5.2"**

Deflection Table - Manufacturer's Proprietary Restrained Joint DIP

Nominal Pipe Size Diameter (D)	Maximum Offset Based on 20 Foot Lengths of Pipe (S)	Design Maximum Deflection Angle ( $\Theta$ )	Minimum Allowable Radius (R)
14-inch to 16-inch	0.83 feet	02°-24' (2.4°)	480 feet
18-inch to 30-inch	0.48 feet	01°-24' (1.4°)	820 feet
36-inch to 54-inch	0.14 feet	00°-24' (0.4°)	2860 feet

d) Wedge action-restraining glands for DIP push-on joints.

- (1) For maximum joint deflections for full-length DIP push-on joint pipe with wedge action restraining glands, see Table "5.3". The maximum deflection angle in table "5.3" is used for design purposes and is based on eighty (80%) percent of the manufacturer's maximum recommended deflection. Check with the manufacturer for availability of this type of restrained joint system **and the maximum total pressure**.
- (2) Only use this restrained joint system when the total working pressure (operating pressure plus surge pressure) is below the pressures in Table "5.3a" and use only on DIP. This restrained joint system must be approved **by WSSC**.

**TABLE "5.3"**

Deflection Table - Wedge Action Restraining Gland – DIP Push-on Joints

Nominal Pipe Size Diameter (D)	Maximum Offset Based on 20 Foot Lengths of Pipe (S)	Design Maximum Deflection Angle ( $\Theta$ )	Minimum Allowable Radius (R)
12-inch and under	1.39 feet	04°-00' (4.0°)	290 feet

**TABLE "5.3a"**

Maximum Total Pressure for Wedge Action Restraining Gland – DIP Push-on Joints

Nominal Pipe Size Diameter (D)	Total Pressure (Operating Pressure plus Surge Pressure)
4-inch to 12-inch	300 psi

e) **Restraining** PVC Push-on pipe.

- (1) For maximum joint deflections for full length restrained PVC push-on pipe with **harness restraint**, see Table "5.4". The maximum deflection angle in Table "5.4" is used for design purposes, and is based on seventy (70%) percent of the recommended deflection set by WSSC for PVC pipe sizes 12-inch and smaller diameter.

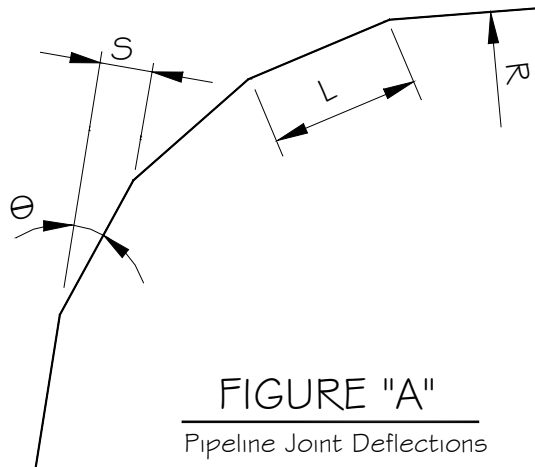

**TABLE "5.4"**  
Deflection Table - Restraining Push-on PVC Pipe

Nominal Pipe Size Diameter (D)	Maximum Offset Based on 20 Foot Lengths of Pipe (S)	Design Maximum Deflection Angle ( $\Theta$ )	Minimum Allowable Radius (R)
12-inch and under	0.48 feet	01°-24' (1.4°)	820 feet

**e. Determining Joint Deflections and Offset Distances.**

- 1) Figure "A" illustrates Formula "A" and shows the variables for determining pipeline joint deflections and offset "S" distances.



**FORMULA "A"**

$$R = \frac{L}{2 \tan (\Theta/2)}$$

**FORMULA "B"**

$$S = \sin \Theta \times L$$

Where:

$\Theta$  = deflection angle

L = laying length (ft)

S = joint deflection offset (ft)

R = radius of curve (ft)

Note: For design purposes, the laying length (L) should be assumed as twenty (20) feet for determining the minimum allowable radius (R).



### 13. Rotation of Fittings.

#### a. Rotation of Bends.

- 1) Bends can be rotated about the pipe axis to produce a simultaneous deflection or combined bend. This section covers the design of horizontal bends rotated in the vertical plane.
- 2) When labeling bends that will be rotated, refer to the amount of rotation as the horizontal and/or vertical deflection angle.
- 3) For the list of allowable bends, see Part One, Section 7 (Allowable Fittings). For ninety (90°) degree bends, the approaching line to the bend must be level (no slope).
- 4) Total deflection angle of the bend must equal the manufacturer's angle and will always be greater than either the horizontal plane (plan view) angle of the bend or the vertical plane (profile) angle of the bend.
- 5) When the rotation of the bend has a rotation angle greater than ten (10°) degrees for pipe sizes 12-inch diameter and smaller and five (5°) degrees for pipe sizes larger than 12-inch diameter, special considerations must be given to restrain the horizontal and vertical components of the thrust force caused by the rotation of the bend. See Part Three, Section 27 (Thrust Restraint Design for Buried Piping).
- 6) Formulas for computing the combined horizontal and vertical deflections are provided below to obtain the required total deflection angle of the bend.
- 7) Determine the vertical alignment (profile). Set the station and invert elevation of the alignment through the bend. Then, use the Formula "C" below to establish the horizontal deflection in plan.

#### FORMULA "C"

To find VD or HD when either is known.

$$\cos B = ((\cos HD \square \cos V \square \cos V') \square (\sin V \square \sin V'))$$

Where:

- B = total manufacturer's deflection angle of the bend (45°, 22-1/2°, or 11-1/4°)
- V = vertical angle of the approaching line (incoming) of the bend with horizontal plane
- V' = vertical angle of the departing line (outgoing) of the bend with horizontal plane
- HD = horizontal deflection of the combined bend
- VD = vertical deflection of the combined bend

(Formula "C" is copied from Price Brothers Catalog, with some modifications)

NOTE A: V and V' are positive or negative if the pipe is sloping upward or downward, respectively, in the direction of laying. For positive V or V', sin V or sin V' and cos V or cos V' are positive. For negative V or V', sin V or sin V' is negative and cos V or cos V' is positive.



The following Sketch "D" is to define the different elements of the above formula.

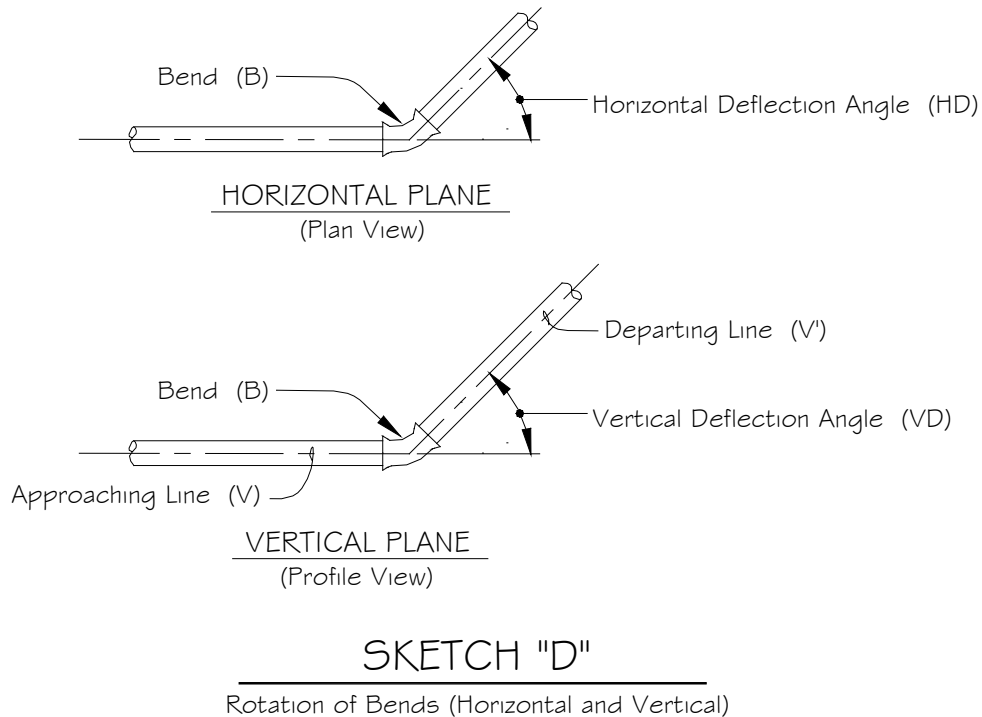

To find the pipe slope of the approaching or departing line in degrees, use the following formula:

#### FORMULA "D"

$$V \text{ and } V' = \tan^{-1} \left( \frac{\text{(Difference between invert elevations)}}{\text{(Distance between invert elevations)}} \right)$$

#### Example: Determine Pipe Slope

The pipe invert elevation station at 0+00 is 250.0 and at 2+00 is 251.0.

$$\begin{aligned} V \text{ and } V' &= \tan^{-1} \left( \frac{\text{(Difference between invert elevations)}}{\text{(Distance between invert elevations)}} \right) \\ &= \tan^{-1} \left( \frac{251.0 - 250.0}{2+00 - 0+00} \right) \\ &= \tan^{-1} (1.0 \div 200) \\ &= \tan^{-1} 0.005 \end{aligned}$$

$$V \text{ and } V' = 0.28647651^\circ \text{ or } 00^\circ 17' 11'' \text{ (Pipe slope in degrees)}$$

If  $V'$  and  $V$  is known then determines HD and VD using the following formula:

#### FORMULA "E"

$$HD = \cos^{-1} \left( \frac{\cos B - (\sin V \sin V')}{\cos V \cos V'} \right)$$

#### FORMULA "F"

$$VD = V \sin V' \quad \text{See Note A, on previous page.}$$



**Example: Determine Vertical Deflection for a Horizontal Bend, Formulas "D", "E" and "F".**

A 24-inch water main has a vertical alignment as shown in the profile below (Sketch "E") and in the horizontal plane we require a 45° horizontal bend. What will be the actual resultant deflection angle in the plan view?

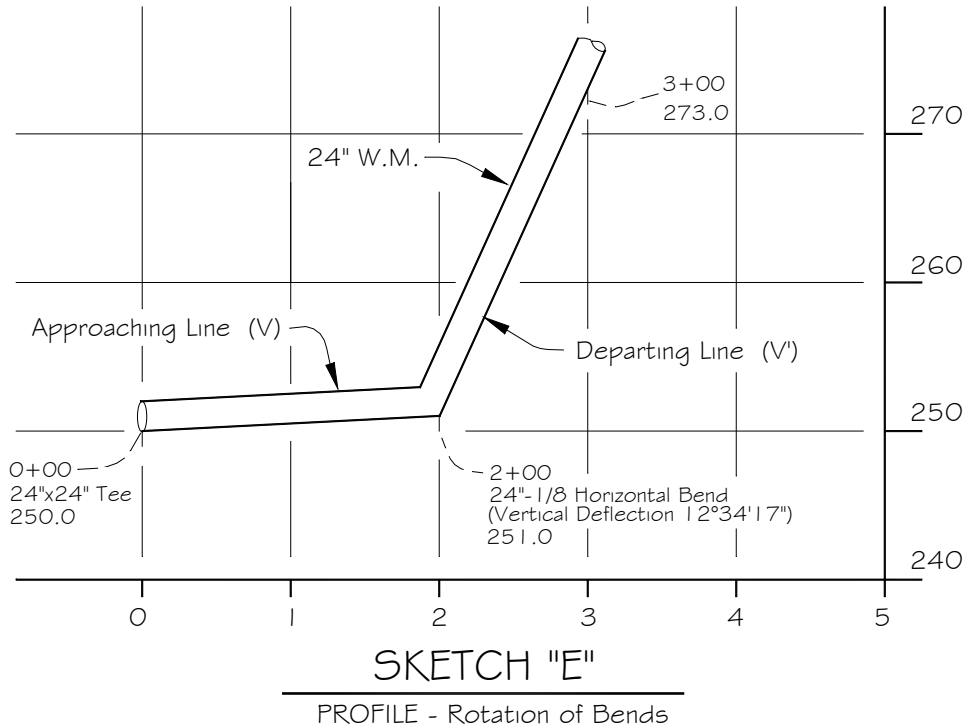

The first step is to determine the vertical deflection angle (VD) for the 45° horizontal bend. Then, using Formula "D", find the pipe slopes for both the approaching line (V) and the departing line (V') in degrees.

$$\begin{aligned}
 V' &= \tan^{-1} \left( \frac{\text{Difference between invert elevations}}{\text{Distance between invert elevations}} \right) \\
 &= \tan^{-1} \left( \frac{273.0 - 251.0}{3+00 - 2+00} \right) \\
 &= \tan^{-1} (22.0 \div 100) \\
 &= \tan^{-1} 0.22 \\
 V' &= 12.407418^\circ \text{ or } 12^\circ 24' 27''
 \end{aligned}$$

$$\begin{aligned}
 V &= \tan^{-1} \left( \frac{\text{Difference between invert elevations}}{\text{Distance between invert elevations}} \right) \\
 &= \tan^{-1} \left( \frac{251.0 - 250.0}{2+00 - 0+00} \right) \\
 &= \tan^{-1} (1.0 \div 100) \\
 &= \tan^{-1} 0.005 \\
 V &= 0.28647651^\circ \text{ or } 00^\circ 17' 11''
 \end{aligned}$$

To find the vertical deflection angle (VD), use Formula "F".





$$VD = V + V'$$

In above profile V and V' are positive because both lines are upward, see Note A.

$$= 12.407418^\circ + 0.28647651$$

$$VD = 12.693895^\circ \text{ or } 12^\circ 41' 38''$$

Second, to determine the horizontal deflection angle (HD), use Formula "E".

$$HD = \cos^{-1} \left( (\cos B - (\sin V \times \sin V')) \div (\cos V \times \cos V') \right)$$

$$= \cos^{-1} \left( (\cos 45^\circ - (\sin 00^\circ 17' 11'' \times \sin 12^\circ 24' 27'')) \div (\cos 00^\circ 17' 11'' \times \cos 12^\circ 24' 27'') \right)$$

$$= \cos^{-1} \left( (0.7071068 - (0.0049984 \times 0.2148632)) \div (0.9999875 \times 0.9766442) \right)$$

$$= \cos^{-1} (0.7071068 - 0.001074) \div 0.976632$$

$$= \cos^{-1} 0.7229261$$

$$HD = 43.703401^\circ \text{ or } 43^\circ 42' 21''$$

After determining the resultant horizontal deflection angle (HD), adjust the horizontal plane to suit the computed resultant horizontal deflection angle.

When the pipeline is 12-inches and smaller, Chart "A" can be used to determine the horizontal deflection angle (HD). When using this chart, the horizontal and vertical angles should be rounded to the nearest one-half degree ( $1/2^\circ$ ). The approaching line must be laid almost level, not to exceed the maximum slope allowed for this chart, which is two ( $2^\circ$ ) degrees or three and one half (3.5%) percent.

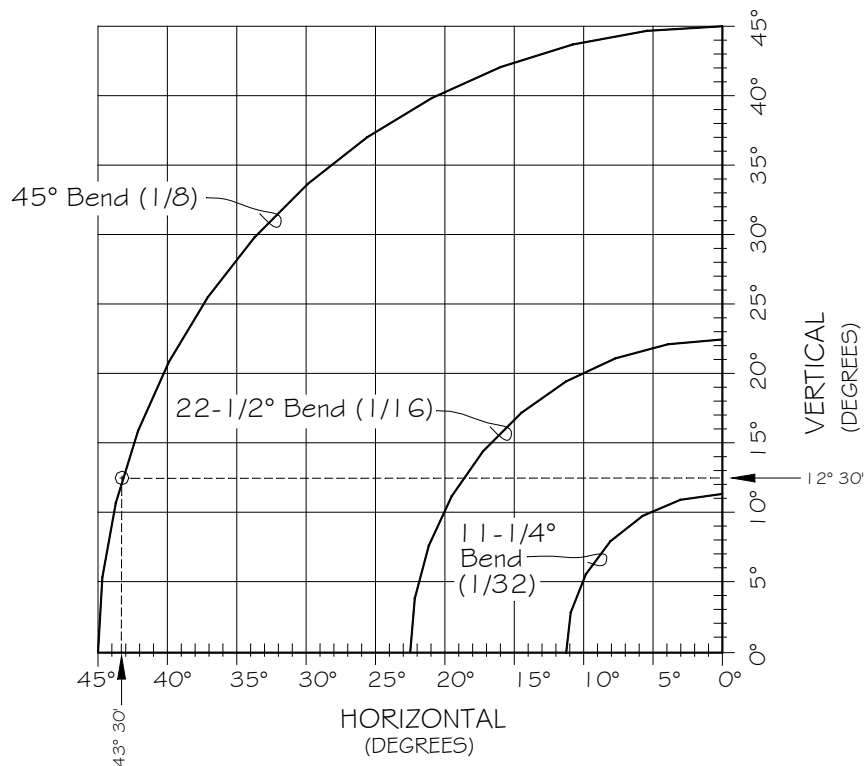

**CHART "A"**

Rotation of Bends



Chart "A" is based on Formula "C"

$$\cos B = ((\cos HD \times \cos V \times \cos V') + (\sin V \times \sin V')), \text{ with } V = 0^\circ$$

**Example: Determine Vertical Deflection for a Horizontal Bend, Chart "A".**

Using the example as previously stated and shown on the profile, determine the vertical deflection angle (VD) and horizontal deflection angle (HD) using Chart "A", for pipelines 12-inch and smaller diameter. Also, Chart "A" could be used as a check for pipelines larger than 12-inch diameter.

$$\begin{aligned} \cos B &= ((\cos HD \times \cos V \times \cos V') + (\sin V \times \sin V')) \\ &= ((\cos HD \times \cos 0^\circ \times \cos V') + (\sin 0^\circ \times \sin V')) \\ &= ((\cos HD \times 1.0 \times \cos V') + (0.0 \times \sin V')) \\ &= (\cos HD \times \cos V'), \quad (V' = VD = V + V' \text{ and } V = 0) \\ \cos B &= (\cos HD \times \cos VD) \end{aligned}$$

$$\begin{aligned} HD &= \cos^{-1}(\cos B + \cos VD) \\ &= \cos^{-1}(\cos 45^\circ + \cos 12^\circ 30') \\ &= \cos^{-1}(0.7071068 + 0.976296) \\ &= \cos^{-1} 0.724275 \\ &= 43.591429^\circ \text{ or } 43^\circ 35' 29", \text{ round to nearest } 1/2^\circ \\ HD &= 43^\circ 30' \end{aligned}$$

**b. Rotation of Tees.**

- 1) When the branch of a tee has a valve on the rotated section of the branch connection, the maximum allowable rotation of the branch connection at the tee is not to exceed three (3°) degrees. Exceptions can be submitted for approval **up to** a maximum of five (5°) degrees for branch connections which are 14-inch and smaller. See Part One, Section 18 (Pipeline Valves).
- 2) When the rotation of a branch connection **does not have a valve connected to the tee and is** ten (10°) degrees or more for pipe sizes 12-inch and smaller diameter or five (5°) degrees or more for pipe sizes larger than 12-inch diameter, special thrust blocking design must be provided for the vertical components of the thrust forces caused by the rotation of the tee. See Part Three, Section 27 (Thrust Restraint Design for Buried Piping).

**c. Rotation of Other Fittings.**

- 1) Rotation of any fittings other than bends or tees is not permitted.



## 14. Joint Deflections at Fittings.

### a. Requirements.

- 1) Deflecting joints at fittings is not permitted. Lay out the alignment to eliminate any deflecting joints at fittings.
- 2) Exceptions to the prohibition on deflecting joints at fittings may be requested for DIP only and after all other reasonable designs have been considered. There is no guarantee that WSSC will give approval for deflecting joints at fittings. Bends may be designed with joint deflections, if thrust restraint design calculations for additional joint deflections **at the bend** are submitted in accordance with Part Three, Section 27 (Thrust Restraint Design for Buried piping) and the joint deflection does not exceed WSSC allowable joint deflections, see Part One, Section 12 (Allowable Joint Deflections). See the following example for deflecting joints at fittings on DIP.

#### **Example: Deflecting Joints at Fittings on DIP.**

Deflecting joints on a standard manufactured 16"- 45° (1/8) bend could make the total bend deflection equal to fifty (50°) degrees.

Using WSSC allowable joint deflections from Part One, Section 12 (Allowable Joint Deflections), for mechanical joint, the allowable joint deflection is 2°24' on each bell joint of the fitting.

Standard Details for blocking are based on forty-five (45°), not fifty (50°) degrees.

If the thrust restraint design calculations for the bend for additional joint deflections are submitted in accordance with Part Three, Section 27 (Thrust Restraint Design for Buried piping) and the joint deflection does not exceed WSSC allowable joint deflections, see Part One, Section 12 (Allowable Joint Deflections), and then the exception may be approved.

- 3) **T**ry to avoid deflecting joints at fittings to allow for any unforeseen adjustments to the alignment during construction.



## 15. Deflection of Pipe Joints.

### a. General.

- 1) Pipe joints may be deflected to obtain a horizontal curvature, vertical curvature or a combination.

### b. Alignment Design.

- 1) Design maximum deflection angle (MD) of any pipe joint in a single plane, or a combination of both planes, cannot exceed the angles shown in the Deflection Tables under Part One, Section 12 (Allowable Joint Deflections). To determine the joint deflection in either the horizontal or vertical planes, use Formula "A" and Figure "A", under Part One, Section 12 (Allowable Joint Deflections).
- 2) When the alignment requires a combination of horizontal and vertical joint deflections, determine the design maximum deflection angle (MD) of the pipe joint using formulas "G", "H" and "I", as shown below. Determine the horizontal joint deflection ( $\Theta_H$ ) using Formula "G".

**FORMULA "G"** See Formula "A" under Part One, Section 13 (Allowable Joint Deflections).

$$H = \Theta_H = 2 \tan^{-1} (L / 2R)$$

After solving horizontal joint deflection (H), solve for the maximum vertical joint deflection (MV) using Formula "H".

**FORMULA "H"**

$$MV = V = \cos^{-1} (\cos (MDA) \cos (H))$$

Where:

MDA = design maximum deflection angle from Tables "3", "3.1", "4", "5.0", "5.1", "5.2", "5.3" and "5.4" (Part One, Section 12 (Allowable Joint Deflections)).

MV = maximum vertical joint deflection angle

V = joint deflection angle in the vertical plane

H = joint deflection angle in the horizontal plane

R = radius of curve

$\Theta_H$  = horizontal deflection angle

$\Theta_V$  = vertical deflection angle

L = laying length (use twenty (20) feet)

After solving for the maximum vertical joint deflection angle (MV) distance, determine the vertical profile of the pipeline alignment by finding the vertical offset distance from Formula "I".

**FORMULA "I"**

$$VS = \sin \Theta L$$

Where:

VS = vertical offset distance

$\Theta$  = vertical deflection

L = laying length (use 20 feet)



**Example: Determining the Vertical Deflections for a Horizontal Curve.**

A curved alignment on a 24-inch pipeline in the horizontal plane (plan view)  $R = 800$  feet. Find the maximum vertical joint deflections (MV) (on profile), by computing the horizontal deflection (H) first and then solve for the vertical angle using Formula "G" and Formula "H".

Using Formula "G"

$$\begin{aligned} H = \Theta_H &= 2 \tan^{-1} (L \div 2R) \\ &= 2 \tan^{-1} (20 \div 2 \times 800) \\ &= 2 \tan^{-1} 0.0125 \\ &= 2 \times 0.71616 \\ H = \Theta_H &= 1.4323199^\circ \text{ or } 01^\circ 25' 56'' \end{aligned}$$

Then, using Formula "H", solve for the maximum vertical joint deflection (MV).

$$\begin{aligned} MV = \Theta_V &= \cos^{-1} (\cos(MD) \div \cos(H)) \\ &\text{for 24" pipeline, push-on joints, from Table "3", } MD = 02^\circ 24' \\ &= \cos^{-1} (\cos 02^\circ 24' \div \cos 01^\circ 25' 56'') \\ &= \cos^{-1} (\cos 02^\circ 24' 00'' \div \cos 01^\circ 25' 56'') \\ &= \cos^{-1} (0.9991228 \div 0.9996876) \\ &= \cos^{-1} 0.999435 \\ MV = \Theta_V &= 1.9260754^\circ \text{ or } 01^\circ 55' 34'' \end{aligned}$$

On each twenty (20) foot length of pipe, the allowable vertical joint deflection is  $01^\circ 55' 34''$ .

Find the offset distance, for each pipe length in the profile (vertical offset distance), using Formula "I":

$$\begin{aligned} VS &= \sin \Theta \times L \\ &= \sin 01^\circ 55' 34'' \times 20 \\ &= 0.0336106 \times 20 \\ VS &= 0.67 \text{ feet} \end{aligned}$$

"VS" is the distance the pipe may be deflected from the previous pipe section, as shown in Sketch "F".

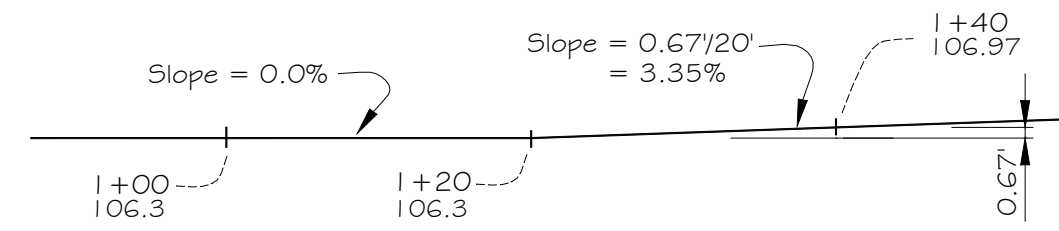

SKETCH "F"

PROFILE - Deflections at Pipe Joints



## 16. Design of Structures.

### a. Standard Details.

- 1) When using the Standard Details for Air Manholes, Valve Vaults, Pressure Reducing Valve Vaults and Relief Valve Vaults, etc., **design** the depth of the proposed pipeline **in accordance with** the Standard Details.

### b. Special Design Structures.

- 1) Specially designed structures are required if the Standard Details are not adequate for the particular design. Provide details on the drawings, showing all necessary plan and section views, and label all materials, dimensions, etc.
- 2) Allow for a minimum of six and one half (6-1/2) feet of headroom inside the proposed structure. The depth of the pipeline should be based on this dimension. For other requirements; see Part Three, Section 15 (Design of Pipeline Structures).
- 3) All pipe connections to vaults shall have a watertight seal using a rubber annular hydrostatic sealing device in accordance with the Specifications and Standard Details.

### c. Design of Structures on Profiles.

- 1) Verify that the invert of the pipeline is set at the proper depth in relation to the elevations/dimensions associated with the details of the structure.

### d. Access Openings.

- 1) Vaults. Provide frame and cover for access into vaults, see Standard Detail W/5.5. If the design requires a hatch, then provide a watertight hatch able to withstand H2O loading; see Specifications and Standard Detail W/5.5. Do not design hatches when the vault is located in a paved area subjected to high density traffic (e.g. streets, parking lots, etc.).
- 2) Manholes. Provide frame and cover for access into manholes, see Standard Details S/4.2 and S/4.3 and Table "10" in Part Two, Section 12 (Design of Structures).

### e. Setting of Frames and Covers or Hatches.

- 1) Design the frames and covers, or hatches, following the guidelines below and provide computations (tabulation sheet) supporting the frame and cover or hatch elevations.
  - a) Within a proposed or future roadway with established road grades, provide the elevation of the top of the manhole or vault frame and cover or hatch, see Sketch "G". When an established roadway grade profile is used to calculate the elevation of the frame and cover, give the elevation to within a hundredth of a foot. When an established roadway grade or grading plan showing contour lines is used to calculate the elevation of the frame and cover or hatch, give the elevation to within a tenth of a foot. If the manhole falls within a roadway indicate the roadway grade slope in percent (%) in the direction of the profile, see Sketch "G".
  - b) Outside limits of grading, design the top of the manhole or vault frame and cover or hatch to



- match the existing ground elevation, see Sketch "H".
- c) Existing areas or developments design the top of manhole or vault frame and cover or hatch to match the existing ground elevation, see Sketch "H".
- d) Undeveloped areas, the top of the manhole frame and cover or hatch are normally designed to be one (1) foot above the existing ground elevation, see Sketch "H".

**f. Labeling Structures on the Drawings.**

- 1) On plan and profile views label vaults and manholes as follows:

Air Release Manhole or Vault	=	AR	Entry Port	=	EP
Valve Vault	=	VV	Blowoff	=	BO
Air Release/Vacuum Relief Manhole or Vault	=	ARVR			

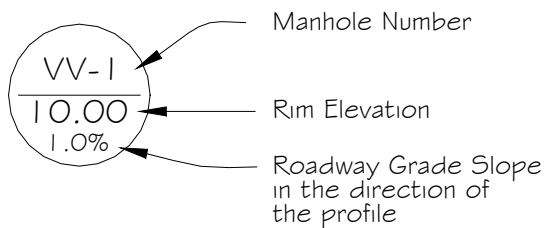

SKETCH "G"

Labeling Manholes or Vaults on  
Proposed or Finished Grades

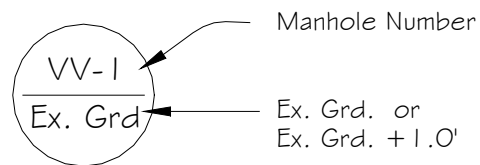

SKETCH "H"

Labeling Manholes or Vaults  
on Existing Grades



## 17. Tunnels or Casing Pipes.

### a. Requirements.

- 1) When crossing MSHA roadways, railroads, **Maryland Transit Administration (MTA) Rail Lines**, and county roadways in which the jurisdictional agency requires the pipeline to be in a tunnel or casing pipe, the following is required:
  - a) Do not grout around water pipelines enclosed in tunnels or casing pipes.
  - b) Design the water pipeline DIP class for the depth without consideration of the tunnel or casing pipe, see requirements for the design of DIP, Part One, Section 4 (Selection of Pipe Material). Do not use PVC pipe AWWA C900 in tunnels or casing pipes.
  - c) **No pipe joint deflections or fittings are allowed in tunnels or casing pipes.**
  - d) Provide minimum **of ten (10) feet** between **the** end of tunnel and **any** fitting on pipeline.
  - e) Provide minimum **of fifteen (15) feet** between end of tunnel and outside wall of concrete thrust **block**; see **Standard** Details B/3.1, B/3.1b and B/3.3.
  - f) Pipelines with restrained joints shall not be designed for use within tunnels or casing pipes unless approved by WSSC.
- d) For requirements on allowable depths of tunnels or casing pipes and detailed design requirements, see Part Three, Section 25 (Tunnels) and Section 26 (Tunnel Design Criteria).
- e) For details on allowable diameters of the tunnels or casing pipes, see Standard Details M/17.1 and M/17.6.
- f) When required, provide access manholes to the tunnels or casing pipes, see Standard Detail M/17.5.

### b. Installing Casing Pipes for Existing Water Pipelines.

- 1) When required, install steel casing pipe only;
  - a) **Determine if alignment has joint deflection or fittings.**
    - (1) **If joint deflection or fittings exists, relocate existing pipeline to remove joint deflection or fittings inside the casing.**
  - b) **Call out to have the existing water pipeline to be out of service.**
  - c) **Design the steel casing pipe to be divided in two (2) sections along casing centerline.**
  - d) **The existing water pipeline may be excavated and exposed along the pipeline only six (6) feet of at any time. This will provide support for the undisturbed pipeline.**





## 18. Pipeline Valves.

### a. General.

- 1) Allowable valves on water pipelines **are** Double Disc or Resilient Seated (Wedge) Gate Valves, which are in accordance with the Specifications and requirements stated in this section.

### b. Valve Types.

- 1) Resilient Seated (Wedge) Gate Valves.
  - a) For Pipelines 12-inches and smaller.
  - b) Use only when Total Pressure (Operating Pressure + Surge Pressure) is less than two hundred and thirty-five (235) psi.
  - c) If Total Pressure is more than two hundred and thirty-five (235) psi, use Double Disc Valves.
- 2) Double Disc Valves.
  - a) For Pipelines 4-inches and larger
  - b) Must label on the plan and profile.  
Example: 12” Double Disc Valve.

### c. Valve Locations.

- 1) Valves on Tees. Locate valves **as follows**:
  - a) **When not located in roadways, locate as** close as possible to all branch connections off the mainline pipeline.
  - b) At an intersection of roadways, locate valve on the projection of the roadway right of way line.
  - c) When valves are located near the connection to the main pipeline and the branch connection is only extended a short distance, restrain the valve to the mainline pipeline; see Standard Detail B/2.1 and Part Three, Section 27 (Thrust Restraint Design for Buried Piping).
- 2) Valves on Fire Hydrants. Locate the valve next to the tee on all fire hydrant leads and restrain all joints on fire hydrant lead, see Part One, Section 24 (Fire Hydrants).
- 3) Valve next to Reducers. If a valve is required in the vicinity of or in close proximity to a reducer, locate the valve on the smaller diameter pipe. See the design requirements for restraining reducers in Part Three, Section 27 (Thrust Restraint Design for Buried Piping).
- 3) Valves larger than 14-inch in diameter. These larger size valves are designed for installation in valve vaults, see requirements under Horizontal Gate Valve Vault Design for Pipelines Larger Than 16-inch diameter, in this section. The design of these vaults and valves will require valve



restraint in the closed position; see requirements in Part Three, Section 27 (Thrust Restraint Design for Buried Piping).

- 5) Double Valves. Two (2) valves are generally used when connecting 12-inch diameter and smaller pipelines to 42-inch diameter and larger mainline pipelines. Provide two (2) valves at the connection.
- 6) Water House Connections 3-inch through 12-inch diameter. Locate valves on the branch connection to the mainline pipeline; see Standard Detail W/5.12.
- 7) Division Valves. Provide division valves when directed by WSSC to divide and interconnect two different pressure zones. Label the valve as a "Division Valve" and indicate the size. Also, indicate if the valve is designed to be closed or open, show the pressure zone boundary lines and indicate the pressure on each side of the boundary.
- 8) Valves for Looped Water Distribution Systems. For water mains that are looped between streets, design valves at both ends, before entering and leaving each street onto private property.
- 9) Valves for Future Extensions. Valves may be needed when a pipeline ends with a plug/cap and it is possible that the pipeline will be extended in the future.
  - a) Locate a valve near the end of the pipeline so that no more than ten (10) domestic services will need to be shut down during the future extension. **Design the valve to be restrained.**

**d. Special Requirements.**

- 1) When a mainline valve is closed on a pipeline that is 16-inch and larger diameter, a low or high point may be created at the closed valve. If this condition occurs on the pipeline, provide a blowoff or air valve.

**e. Valve Size.**

- 1) Table "6" indicates the valve size required for each pipeline diameter.

**TABLE "6"**  
Valve Sizes

Diameter Pipeline	Valve Size
14-inch and smaller	Same size as pipeline
16-inch	14-inch valve with 16"x14" Reducers
Greater than 16-inch to 54-inch	Same size as pipeline
Larger than 54-inch	Consult WSSC for valve size

**f. Valve Spacing.**

- 1) A sufficient number of valves shall be provided on the water pipelines to minimize inconvenient **shutdowns** and sanitary hazards during repairs.
- 2) Table "7" indicates the maximum distance allowed between valves on a pipeline.



**TABLE "7"**  
Spacing of Valves

Diameter Valves	Maximum Spacing of Valves
4-inch to 6-inch	every 800 feet
8-inch to 12-inch (Multi-Family Residential Use)	every 800 feet
8-inch to 12-inch (Single Family Residential Use)	every 1000 feet
8-inch to 12-inch ( Commercial Areas)	every 500 feet
8-inch to 12-inch (Other)	every 1200 feet
14-inch (on 16-inch pipeline with WHC)	every 1200 feet
14-inch (on 16-inch pipeline with no WHC)	every 1200 feet
20-inch	every 2,000 to 2,500 feet
24-inch to 48-inch	every 2,500 feet
larger than 48-inch	as directed by WSSC

**g. Restraining of Valves.**

- 1) For valve thrust restraint design, see Part Three, Section 27 (Thrust Restraint Design for Buried Piping).

**h. Plan Design Information.**

- 1) **If shutdowns are required, indicate the distance from all existing adjacent valves. Provide the associated valve numbers.**
- 2) Valve stem extensions are required when the top of the valve's operating nut exceeds four (4) feet of cover. Provide the following note on the drawings: "Provide valve extension stem, See WSSC Standard Detail W/2.2".

**i. Profile Design Information.**

- 1) Provide a minimum of two (2) feet of cover over the valve operating nut or four (4) feet of cover over the pipeline, whichever is greater.
- 2) Design the pipeline at the valve, with almost no vertical slope with the following exceptions:
  - a) The maximum allowable pipe slope at the valve is three (3°) degrees (5.24%).
  - b) Valves 12-inch diameter and smaller: Where the depth of the pipeline does not require the valve to have a valve extension stem added, the maximum allowable pipe slope is five (5°) degrees (8.75%), see Sketch "I".
  - c) When the valve is located on a pipeline that is not level (on a slope), check the pipe slope and depth of the valve to verify that the buried valves are operable.



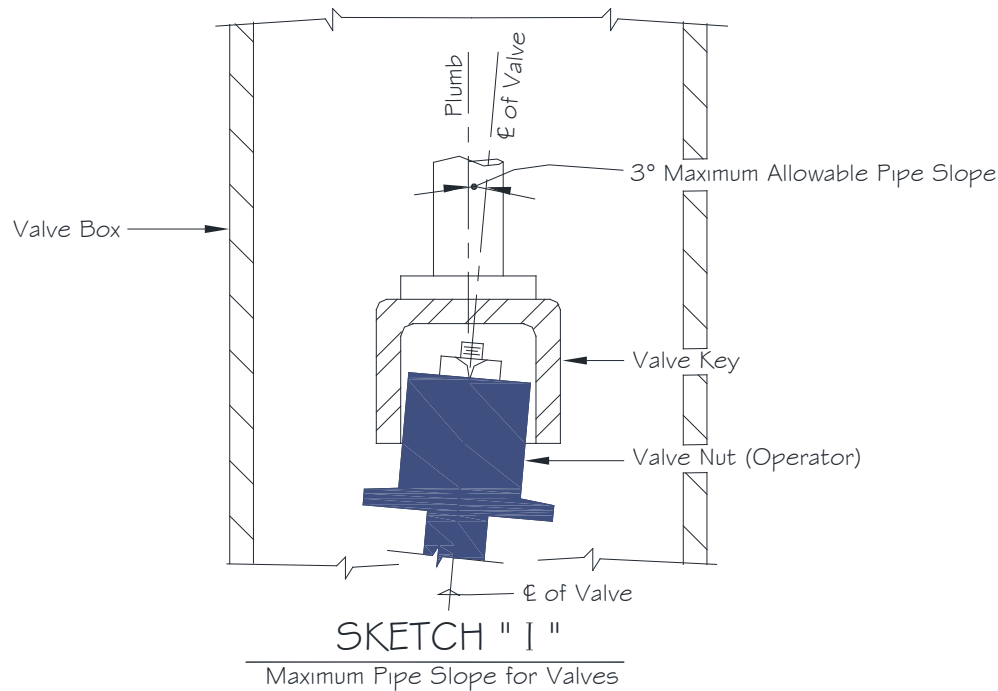

**j. Type of Valves (Double Disc Gate Valves and Resilient Seated (Wedge) Gate Valve)**

1) Double Disc Gate Valves.

(a) Vertical Double Disc Gate Valves.

- (1) Double disc gate valves 12-inch and smaller shall be vertical valves with mechanical joint ends for direct buried service and flanged ends for non-direct buried service.
- (2) Vertical valves for pipelines 16-inch and larger require WSSC approval. Locate the valve in a valve vault (see Standard Detail W/2.6) for 20-inch valves. Provide for flanged ends on the valve. Larger vertical valves in vaults will require special design details to be shown on the drawings and if the design requires the use of 16-inch and larger vertical valves, provide Special Provisions to Specifications.
- (3) Valves must have a standard operating nut. If hand-wheel operations are required, provide Special Provisions to Specifications.
- (4) If the design requires a change to the above requirements for vertical valves, submit the appropriate changes to WSSC for approval.

(5) Design Requirements.

- (a) Mechanical joint or flanged vertical valves, 14-inch and smaller, Class 125. These valves are designed to withstand and operate up to a non-shock working pressure of two hundred (200) psi. For design purposes, use ninety (90%) percent of two hundred (200) psi or one hundred eighty (180) psi working pressure. For requirements of Class 125 valves, see Specifications. If the valve requires flange ends, use ANSI B16.1, Class 125.



- (b) Mechanical joint or flanged vertical valves 14-inch and smaller, Class 250. When the non-shock working pressure exceeds one hundred eighty (180) psi, provide Class 250 valves. For requirements of Class 250 double disc gate valves, see Specifications. If the valve requires flanged ends, use ANSI B16.1, Class 250, flat face. See requirements under Part One, Section 3 (Pipe and Fitting Joints) and Section 7 (Allowable Fittings) for information on connecting ANSI B16.1 Class 250 flanged pipe and fittings.

b) Horizontal Double Disc Gate Valves.

- (1) Gate valves 16-inch and larger shall be flanged horizontal valves and designed for installation in valve vaults.
- (2) Valves 8-inch and smaller which are installed horizontally in a vault, shall be designed so that the valve has a bevel gear and a right angle gear box, see Specifications. Typically, this type of horizontal design is for the installation of an air valve in a vault.
- (3) If the design requires a change to the above requirements for horizontal valves, submit the appropriate **changes to WSSC for approval.**

(4) Design Requirements.

- (a) Valves 16-inch and larger, Class 125. These valves are designed to withstand and operate up to a non-shock working pressure of one hundred fifty (150) psi. For design purposes, use ninety (90%) percent of one hundred fifty (150) psi or one hundred thirty five (135) psi working pressure. For requirements of Class 125 valves, see Specifications. If the valves require flange ends, use ANSI B16.1, Class 125.
- (b) Valves 16" and larger, Class 250. When the non-shock working pressure exceeds one hundred thirty five (135) psi, provide Class 250 gate valves. For requirements of Class 250 double disc gate valves, see Specifications. If the valve requires flanged ends, use ANSI B16.1, Class 250, flat face. See requirements under Part One, Section 3 (Pipe and Fitting Joints) and Section 7 (Allowable Fittings) for information on connecting ANSI B16.1, Class 250 flanged pipe and fittings.

2) Resilient Seated (Wedge) Gate Valve (RSGV)

- a) When using valves with mechanical joint, flanged or push-on ends, 36-inch and smaller, see the Specifications. Exceptions can be requested from WSSC, by submitting design requirements and Special Provisions to Specifications.
- b) Valve Design Requirements. Design valves for a minimum total pressure (operating plus surge pressure), of two hundred **and thirty-five (235) psi.** When total pressure exceeds two hundred **and thirty-five (235) psi,** use Class 250 Double Disc Gate Valve.

**k Horizontal Gate Valve Vault Design for Pipeline Valves 16-inch Diameter and Larger.**

- 1) Pipelines Valves 16-inch and larger shall be flanged and designed for installation in valve vaults. For pipelines 36-inch diameter and smaller, see Standard Details W/2.4 and W/2.4a. Valves 42-inch and larger, required submittal of vault design for approval.
- 2) For sizing valves on pipelines, see Valve Size, in this section.



- 3) When designing a TS&V with a 16-inch and larger valve, the tapping sleeve or tapping assembly is to be housed in the vault.
- 4) When reducing the pipeline at the valve, the profile must be examined to see if the reducer will create a high point. If so, use an eccentric reducer, designing the straight side of the eccentric reducer to match the top of the pipe elevations on both sides of the pipeline.
- 5) Include in the vault piping a mechanical coupling or mechanical joint solid sleeve for the removal of the valve, pipe and fittings within the vault. Mechanical couplings require special pipe restraints, (see Standard Detail B/3.0) or mechanical joint solid sleeves, either a "short" or "long" type of solid sleeve, see WSSC Standard Details W/2.4 and W/2.6. Mechanical joint solid sleeves require the joints to be restrained using wedge action retainer glands, see Standard Detail B/2.7.
- 6) All pipe **entry points** to vaults shall have a watertight seal. Provide a rubber annular hydrostatic sealing device in accordance with the Specifications and Standard Details.
- 7) The size of the vault can be determined by the dimensions of each valve, pipe and fitting that **are** required in the vault. Larger size valves that are not covered by standard details must be designed on a case by case basis. Submit vault piping design for approval **using** Standard Details W/2.4 and W/2.6 as a guide.
- 8) Design the vaults for valves 16-inch and larger as poured in place concrete vaults and give the option to the contractor to provide pre-cast concrete vaults.
- 9) On **the** profile determine the invert of the pipeline using the design depth shown on the details for the valve vaults.
- 10) For additional structure design requirements, see Part One, Section 17 (Design of Structures).
- 11) Valve extension stems will be required on all valves in vaults if the valve stem operator nut is four (4) feet or more below the existing or finished grade. When extension stems are required, refer to Standard Detail W/2.2 on the drawings.
- 12) Design thrust restraint for the valve in the closed position; see requirements in Part Three, Section 27 (Thrust Restraint Design for Buried Piping).
- 13) Coordinate with WSSC when valves on the project may need to be pre-purchased. WSSC will only pre-purchase valves if construction time for the pipeline is not sufficient for valve delivery when valves are ordered by the contractor. Furnish all the necessary information to WSSC for pre-purchasing of the valves.



## 19. Air Valves.

### a. General.

- 1) WSSC defines air valves as referenced in this manual as follows:
  - a) The 2-inch air valve is a universal type, combination air/vacuum valve and air release valve. For more information, see Specifications.
  - b) The 3-inch and larger combination air and vacuum valve incorporates the functions of two (2) valves. The first valve connects directly to the pipeline and is an air/vacuum valve. The second is an air release valve that is connected on the side of the air/vacuum valve. For more information, see Specifications.
- 2) Generally, air valves or combination air and vacuum valves include two different types of valves; a large orifice air/vacuum valve and a small orifice air release valve. Air/vacuum valves allow the escape of large quantities of entrapped air during line filling and permit air to enter during line draining. In both cases, relatively small pressure differentials are produced across the valves. Air release valves also allow the escape of accumulated air at relatively high pressures experienced under normal pipeline operating conditions.

### b. Specification Requirements.

- 1) Size of the air valve and orifice: see Specifications.
- 2) Combination air and vacuum valve: see Specifications. Show the following on the drawings:
  - a) Size of both the air/vacuum valve and air release valve, including the orifice size of the air release valve.
  - b) Model numbers of the air/vacuum valve and air release valve.
  - c) Type of flanged joint for the inlet of the air/vacuum valve and the gate valve, either ANSI B16.1, Class 125 or 250 flanges.

### c. Design Requirements for 16-inch and Larger Pipelines.

- 1) Determine the appropriate location for all air valves or combination air and vacuum valves; see Location of the Air Valve or Combination Air and Vacuum Valve, in this section.
- 2) Determine the size of air valves or combination air and vacuum valves as follows:
  - a) Pipelines 16-inch to 24-inch. Use a standard 2-inch air valve; see Standard Detail W/2.0. Considerations should be given to assessing possible cases or operating conditions that may call for different valve and orifice sizes.
  - b) Pipelines larger than 24-inch. Submit design and computations for sizing of combination air and vacuum valves. Indicate the type and size of valves on the drawings, and refer to Standard Details W/10.0, W/10.1 and W/10.2. Also see the Specifications and Drawing Requirements in this section.



- c) Check the type and size of air/vacuum valves and air release valves against the manufacturer's specifications to ensure consistency between valve type, size, model number and applicable operating pressure range.

**d. Sizing of Air/Vacuum Valves.**

- 1) The size of the air/vacuum valve is based on manufacturer's valve performance curves. Determine the largest valve size required by considering both normal operating conditions and catastrophic conditions. Air/vacuum valve sizes need not be the same for all locations.
- 2) Consider air/vacuum valve sizing for slow venting of air during line filling. The rate of air venting should equal the rate of line filling to minimize surge effects, which tend to generate high in-line pressures.
- 3) Consider air/vacuum valve sizing for admission of air into the pipeline to compensate for negative pressures generated under normal operating conditions, thereby maintaining a balanced atmospheric pressure in the line. Evaluate the extent of negative pressure that a pipeline can withstand under buried conditions using acceptable calculations and structural design. Use manufacturer's recommendations for appropriate valve sizing.
- 4) Negative pressures may develop in the pipeline under normal operation or catastrophic conditions. Under normal operations, the design of air/vacuum valves shall consider the following situations:
  - a) During draining of a pipeline, the blowoff connection will be opened to drain the pipeline. Size the air/vacuum valves to admit air into the pipeline at the maximum, instantaneous rate of water discharging through the blowoff connection. Depending on the pipeline profile configuration and the relative locations of air valves and blowoff connections, one air/vacuum valve may respond to more than one blowoff. In such cases, consider operating multiple blowoffs.
  - b) During closure of mainline valves, negative pressure may develop in the pipeline, downstream of the mainline valve. The air/vacuum valves can be sized to admit air at the flow rates under which closure of mainline valves can occur. For a large transmission pipeline, a transient water hammer analysis may be required to determine the appropriate size for the air valve or other methods of transient control.
- 5) Consider the possibilities of the occurrence of catastrophic conditions, such as water column separation due to hydraulic transient conditions or line breakage at a low point. Under such conditions, it is necessary to estimate the rate at which an internal vacuum may occur. Large size air/vacuum valves may be used as a method to relieve the vacuum pressure. It may be impractical to size vacuum valves due to an excessively high rate of vacuum occurrence, such as caused by gravity drain of a downward sloping pipeline under high head, therefore, make reasonable assumptions.

**e. Sizing of Air Release Valves.**

- 1) Use design charts provided by the manufacturer to determine the orifice size required for an estimated rate of air release under a certain range of operating pressures.





- 2) Consider design flow demands, pipe slopes, **and** solubility of air in water as affected by temperature and air intake rate through air/vacuum valves under normal operating conditions for the estimation of rate of air release.
- 3) Consider various combinations of operating pressures and air release rates to determine the optimum size of the air release valve. The sizes of air release valves need not be the same for all locations along the pipeline.

**f. Location of the Air Valve or Combination Air and Vacuum Valve.**

- 1) At a minimum, design the air valve or combination air and vacuum valve at each high point of the pipeline in profile.
- 2) Minimize the number of air valves or combination air and vacuum valves required since these valves are susceptible to problems in operation and maintenance.
- 3) A profile which clearly shows the high points, low points and slope changes shall be prepared for the pipeline under design, see requirements for profiles in Part One, Section 11 (Vertical Alignment - Profiles). Upward sloping and downward sloping sections shall be identified in reference to the predominant flow direction. Select locations of the air valves prior to sizing and show on profiles.
- 4) Exercise judgement in selecting the number and location of the air valves or combination air and vacuum valves. Consider the following guidelines, in selecting the locations of the air valves or combination air and vacuum valves (The following guidelines discuss the need for air/vacuum valve and/or air release valves, which are part of the air valve or combination air and vacuum valve.)
  - a) The high point is a location where an upward sloping profile changes to a downward sloping profile. Place air/vacuum valves and air release valves at all high points.
  - b) For pipelines with a decrease in upward slope, small orifice air release valves shall be placed on the downstream, less steep side of the slope change. Where there is a drastic decrease in upward slope, a large orifice air/vacuum valve may be needed.
  - c) For pipelines with an increase in downward slope, place the air release valves on the downstream, steeper side of the slope change.
  - d) For pipelines with long ascending slopes, place the air/vacuum valve at 1/4 to 1/2 mile intervals along the upward sloping profile.
  - e) For pipelines with long descending slopes, place the vacuum valves and air release valves at 1/4 to 1/2 mile intervals along the downward sloping profile.
  - f) For pipelines with horizontal profiles (zero slope), place the air/vacuum valves and air release valves at 1/4 to 1/2 mile intervals. Ideally long horizontal lines should be avoided in profiling a water pipeline.
  - g) At mainline valves on the pipeline, air/vacuum valves may be used to relieve negative pressures



that may develop on the downstream side of the mainline valves when they are closed.

- h) For pipelines where a predominant flow direction cannot be defined, place the air/vacuum valves and air release valves at or near the high points, slope changes and along long pipeline profiles.
- g. Connecting the Air Valve or Combination Air and Vacuum Valve to the Mainline Pipe.**

1) Type of connection for the air valve or combination air and vacuum valve on the pipe section:

(a) For 2-inch and smaller valves, use a tapped corporation stop.

(b) For 3-inch to 8-inch valves, use a flanged welded-on connection and coordinate the flanged inlet of the air valve with the design of the gate valve, see Part One, Section 18 (Pipeline Valves).

(c) Larger than 8-inch valves, use a flanged tee and coordinate the flanged inlet of the air valve with the design of the gate valve, see Part One, Section 18 (Pipeline Valves).

2) Center the location of the air valve or combination air and vacuum valve on a twenty (20) foot length of pipe with both ends of the pipe section having the same elevation.

#### **h. Piping and Vault Configuration.**

1) Pipelines 24-inch and smaller. Use a 2-inch air valve; see Standard Details W/2.0.

2) Pipelines larger than 24-inch.

a) 2-inch air valve on pipelines larger than 24-inch.

(1) If the design requires a 2-inch air valve, modify Standard Detail W/2.0. Modifications to the standard detail must be shown on the drawing, see Part Three, Section 6 (Modifications to Specifications and Standard Details).

(2) If the design requires a 2-inch air valve with an entry port, modify Standard Details W/10.5. Modifications to the standard detail must be shown on the drawing, see Part Three, Section 6 (Modifications to Specifications and Standard Details).

b) 3-inch and larger air valve.

(1) If the design requires a 3-inch and larger valve, see Standard Details W/10.0, W/10.1 and W/10.2.

(2) If the design requires a 3-inch and larger valve with an entry port, see Standard Detail W/10.5.

c) The discharge piping for combination air/vacuum valves with air release valve has two (2) different discharge outlets that are not to be connected together. The discharge piping shall be designed to discharge freely outside the vault/structure to the atmosphere. See Standard Details W/2.0, W/2.0a, W/2.0b, W/10.0, W/10.1 and W/10.2.

3) On profile, determine the invert of the pipeline by using the design depth as shown on the details



for the above mentioned vaults and manholes, see the requirements in Part One, Section 16 (Design of Structures).

- 4) Vent boxes.
  - a) For 2-inch air valve, show the vent box location on the drawings; see Standard Detail W/2.0a.
  - b) For 3-inch or larger air valve, show the vent box location on the drawings, see Standard Detail W/2.0b.
  - c) Provide the dimension from the centerline of the air valve structure to the centerline of the vent box on the drawings.
  - d) If the vent box is located in the 100 year flood plain set the discharge of the vent pipe outlet one (1) foot above the 100 year flood plain elevation. Indicate the discharge elevation and the 100 year flood plain elevation on the drawings.
  - e) If the vent box is to be located in a proposed area (grading), indicate the finished grade elevation at the **vent box top of slab** on the drawings.



## 20. Entry Ports.

### a. General Requirements.

- 1) Entry ports **on pipelines** are required **to be** 36-inch and larger diameter.
- 2) Locate entry ports along the pipeline:
  - a) Maximum spacing of entry ports shall be every two thousand (2000) feet.
  - b) Entry port should not be located at a low point on the pipeline.
  - c) Whenever possible, locate an entry port at every high point, with a maximum spacing of two thousand (2000) feet.

### b. Piping and Vault Configuration.

- 1) For the piping and vault configuration for 36-inch to 48-inch diameter pipelines, refer to Standard Detail W/10.3. For pipelines larger than 48-inch diameter, provide design and details.
- 2) The minimum size of the entry port opening shall be 30-inch diameter for 36-inch **and larger diameter pipelines**.
- 3) **When extending or relocating an existing 30-inch and larger PCCP water mains, design a entry port vault within fifteen (15) feet from the end of the existing PCCP water pipeline.**
- 4) Provide a flanged tee for the entry port for 36-inch to 48-inch pipelines. For pipelines larger than 48-inch diameter, the flanged tee is not in accordance with AWWA C110, therefore verify layout dimensions and pressure rating of the tee with the manufacturer. Provide pipe and vault configuration similar to Standard Detail W/10.3.
- 5) Provide a blind flange designed to plug the branch outlet of the tee with the following requirements:
  - a) The material for the blind flange is to be steel, and shall meet the requirements of AWWA C207 and the Specifications. Specify the class of flange (per AWWA C207 standards) on the drawings.
  - b) Provide a total of four (4) lifting handles on the blind flange, placed ninety (90°) degrees apart, see Standard Detail W/10.4.
  - c) Provide a **4-inch blowoff** valve on the top of the blind flange; see Standard Detail W/10.4.
- 6) Locate entry port in a vault; see Standard Detail W/10.3.
  - a) Provide platforms in the vault along the pipeline for access into the entry port tee; see Standard Detail M/22.0.
  - b) Do not encase the joints on the entry port tee with concrete.



## 21. Air Valves with Entry Port.

### a. General Requirements.

- 1) When either air valves or combination air and vacuum valves and entry ports are within a short distance of each other, design both in the same vault according to the guidelines in this section and in Part One, Section 19 (Air Valves) and Section 20 (Entry Ports).

### b. Piping and Vault Configuration.

- 1) For the sizing and design of the air valve or combination air and vacuum valve, see requirements under Part One, Section 19 (Air Valves) and locate the valve in the vault as follows:
  - a) For 2-inch and smaller air valves, provide a detail on the drawing and connect to the pipeline in the vault with a tapped corporation stop, as follows:
    - (1) Maintain a minimum distance of one and one half (1-1/2) feet from the flanged joint of the entry port tee to the tapped corporation stop.
    - (2) Maintain a minimum distance of one and one half (1-1/2) feet from the vault wall to the tapped corporation stop.
  - b) For 3-inch and larger combination air and vacuum valves, connect the valve to the pipeline with a welded-on connection in the vault as shown on Standard Detail W/10.5 and as follows:
    - (1) Maintain a minimum distance of two (2) feet from the flanged joint of the entry port tee to the welded-on connection.
    - (2) Face the small air release valve toward the entry port tee.
    - (3) Maintain a minimum distance of one and one half (1-1/2) feet from the vault wall to the welded-on connection.
- 2) For information on Entry Ports, see requirements under Part One, Section 20 (Entry Ports) and locate the entry port in the vault as follows:
  - a) For pipelines 36-inch to 48-inch diameter, see Standard Detail W/10.5.
  - b) For pipelines larger than 48-inch diameter, see requirements under Part One, Section 20 (Entry Ports).



## 22. Specialty Valves.

### a. Types of Specialty Valves.

- 1) Use of the following specialty valves is covered in this section: Altitude Valve, Pressure Reducing Valve, Pressure Relief Valve, Swing Check Valve, Backflow Preventer, Butterfly Valve, Eccentric Plug Valve and Line Stops.

### b. General Requirements for Valve and Piping Arrangement in Vaults.

#### 1) Vault Location and Layout.

##### a) Location of vaults:

- (1) Locate vaults out of the **public** roadway right of way. Provide **easement** and construction strips for vault and piping; see Part Three, Section 2 (**Easements** and Construction Strips).
- (2) Vaults shall be out of paved roadways, **where possible**.
- (3) Vaults shall be located away from drainage paths to prevent storm water from flowing into the vault.
- (4) **Do not use PVC AWWA C900.**

#### 2) Design of Vault Structures.

- a) Allow a minimum of six and one half (6-1/2) feet of headroom inside the vault structure. The depth of the pipeline should be based on this dimension. For other requirements, see Part Three, Section 16 (Design of Pipeline Structures).
- b) **For specialty valves, provide** the minimum clearance above and below the specialty valve, per the manufacturer's requirements for maintaining the valve. For minimum inside height dimensions of the vault and additional design requirements, see Part One, Section 17 (Design of Structures).
- c) All pipe **entry points** into vaults shall have a watertight seal. Provide rubber annular hydrostatic sealing device in accordance with the Specifications and Standard Details.
- d) Provide a sump **pit** in the vault.
- e) If **an** equipment access **hatch** is not provided directly over the specialty valve in the vault, provide lifting hooks in the under side of top slab directly over the specialty valve, see Standard Detail W/10.0. The lifting hook and top slab must be designed to handle the additional loads that will be transmitted to the lifting hook and to the top slab; **see Detail W/10.0.**
- f) Access to the vault location. When the vault location requires WSSC to detour traffic or close the roadway to traffic for maintenance of the vault, provide vehicle access to the vault. (Driveway, curb cutouts, etc.)



- g) For additional structural design requirements for vaults, see Part One, Section 15, (Design of Structures) and Part Three, Section 16, (Design of Pipeline Structures).
- h) See requirements under WSSC Design Guideline 28-ME-DG-03, "Mechanical and Electrical Design Guidelines for Control Valve Vaults in the Water Distribution System that are to be Electrically Operated and Remotely Controlled".
- i) Standard Details.
  - (1) When using the Standard Details for Pressure Reducing Valves and Pressure Relief Valves, verify that the depth of the proposed pipeline is adequate for the use of the Standard Details.
  - (2) The maximum vertical depth from the finished grade to the top of the bottom slab of Pressure Reducing Valve Vaults and Pressure Relief Valve Vaults shall be ten (10) feet.
    - [a] If the mainline water pipeline requires the bottom of the vault to be greater than the ten (10) feet vertical depth, design the piping from the mainline water pipeline to the vault to meet the requirements of the ten (10) feet vertical depth. Provide this design on the drawing, showing all necessary plan and section views, and label all materials, dimensions, etc.
    - [b] Soil investigation requirements for the use of Standard Details for Pressure Reducing Valve and Pressure Relief Valve Vaults.
      - [1] Provide a soil boring at the proposed location of the Pressure Reducing Valve Vault or Pressure Relief Valve Vault, see Part Three, Section 19, (Geotechnical and Corrosion Submittals), for soil boring location requirements. Use the information on the boring logs to confirm the elevation of the groundwater table, prior to using the Standard Details for Pressure Reducing Valve Vaults and Pressure Relief Valve Vaults.
      - [2] Elevation of groundwater table must be at least two (2) feet below the bottom slab elevation of the Pressure Reducing Valve Vaults or Pressure Relief Valve Vaults. If the actual groundwater table is higher than the above, the Standard Details must be modified or provide a specially designed structure, see requirements for Special Design Structures.
- j) Special Design Structures.
  - (1) Special designed structures are required if the Standard Details are not adequate for the particular design. Provide details on the drawings, showing all necessary plan and section views, and label all materials, dimensions, etc.
  - (2) When the soil investigation indicates that the elevation of the groundwater table is higher than two (2) feet below the bottom slab elevation of the Pressure Reducing Valve Vaults or Pressure Relief Valve Vaults, including special designs for waterproofing and dampproofing. See requirements under WSSC Design Guideline 28-ME-DG-03, "Mechanical and Electrical Design Guidelines for Control Valves Vaults in the Water Distribution System that are to be Electrically Operated and Remotely Controlled".



- (3) For other design requirements, see information listed under each type of specialty valve.
- 3) Vault Access.
- a) For additional requirements for vault access, see requirements listed under each type of specialty valve.
  - b) When hatches are provided, design the hatch drain as follows:
    - (1) When the top slab is set above grade, design the hatch drain to discharge outside the vault.
    - (2) When the hatch is set to grade, design the hatch drain to discharge into the vault, see Standard Details W/4.2, W/4.3 and W/4.4 for additional requirements.
- 4) Vault Piping.
- a) Provide adequate space between the bolted flanges and the wall where pipes enter and exit the vault, see Part Three, Section 14 (Pipe Joint Clearances within Structures).
  - b) Provide adequate support for all valves and piping within the vault, see Standard Detail W/2.4 for typical design requirements.
  - c) Provide a mechanical coupling, see Standard Detail B/3.0 or a mechanical joint solid sleeve with wedge action retainer gland; see Standard Detail B/2.7.
  - d) Provide flanged ends with pressure ratings similar to gate valves (Class 125 or 250 valves); see Part One, Section 19 (Pipeline Valves) for requirements.
  - e) Verify the pressure rating of the specialty valve. Provide the setting information on the Drawings in accordance with Standard Detail W/4.4.
  - f) For additional requirements for vault piping, see requirement listed under each type of specialty valve.

**c. Altitude Valves.**

- 1) In most cases, altitude valves are designed for installation at water storage facilities (elevated tanks, standpipes or reservoirs). The altitude valve controls the water level in the facility at a specified level and prevents overflow. Altitude valves can be designed to operate in two ways.
  - a) The first way is to only control the filling or refilling of the facility when the water level is low. A check valve or other means to control the withdrawal of water from the facility is required. This type of altitude valve is called a single acting altitude valve.
  - b) The second way is to control both the filling/refilling and the withdrawal of water from the facility. This valve will control both the water level of the facility and the operating pressure of the piping system. When the water level in the facility is low, the valve will open and allow the facility to refill and when the piping system is below the system operating pressure, the valve will open and allow the facility to maintain a level of pressure in the piping to operate the





pipng system. The valve will close when both the facility and the piping system are at the designed operating level. This type of altitude valve is called a double acting altitude valve.

- c) WSSC normally designs systems using the single acting altitude valve. WSSC will provide guidance on the type of altitude valve to be used.

2) Altitude valve and piping arrangements.

- a) Design a vault to house the altitude valve and appurtenances. For additional requirements, see General Valve and Piping Arrangements in Vaults, in this section. Do not design the altitude valve for direct buried service.

- b) Access Openings. Provide two openings:

- (1) Equipment access opening directly over the center of the altitude valve for removal of the altitude valve.

- (2) Personnel access opening located between the altitude valve and the bypass piping or offset to one side. If only the altitude valve is located within the vault, locate the personnel access opening in such a way that there are no obstructions to climb up and down the ladder. **Typical to Details W/5.22 and W/5.23.**

- c) Piping Layout. Provide valves on each side of the altitude valve for maintenance or removal of the valve. Design a bypass line with a closed plug or gate valve around the altitude valve. WSSC will provide guidance on the type of valves to be used.

**d. Pressure Reducing Valves (PRV)**

- 1) WSSC will provide project specific requirements when the installation of a pressure reducing valve.

- 2) In most cases, pressure reducing valves are designed for connecting a higher pressure zone to a lower pressure zone.

- 3) A pressure reducing valve is used whenever a water pipeline of high working pressure needs to be reduced to a lower working pressure.

- 4) In most cases when a pressure reducing valve is required, the installation of a pressure relief valve will also be required, see requirements for Pressure Relief Valves in this section.

- 5) Pressure reducing valves can be designed to operate in three ways.

- a) The first way is to reduce the head in a transmission main connecting to a distribution system or reinforce the low pressure zone during periods of high demands. Typically, only one pressure reducing valve is installed with bypass piping.

- d) The second way is to install two pressure reducing valves; a larger one to handle peak flows or fire flows and a smaller one to handle low flows. Usually the smaller valve is adjusted for a discharge pressure setting of five (5) psi above the setting of the larger valve so that the smaller valve will handle the low flow requirements. The larger valve opens only when demands exceed



the capacity of the smaller valve, causing the pressure to drop to the pressure setting of the larger valve.

- c) The third way is for use with water house connections. When the working pressure in the distribution main is over eighty (80) psi (static), the installation of a pressure reducing valve on the water house connection is required. This pressure reducing valve is typically installed after the meter, inside the house/building. For requirements, see The Plumbing Code.
  - d) Pressure reducing valves can be designed to operate in other ways not listed above, such as in cases when the design requires a device to control surges or to reverse the direction of the pipe flow. If the above types of conditions are encountered, follow the requirements stated in this section.
- 6) Pressure reducing valve and piping arrangements.
- a) Piping layout.
    - (1) See requirements under General Valve and Piping Arrangements in Vaults, in this section and the following requirements:
      - (a) For pressure reducing valve sizes 12-inch and smaller diameter, see Standard Details W/4.2, W/4.3 and W/4.4.
      - (b) For pressure reducing valve sizes larger than 12-inch, provide details on the drawings. Design the vault to house the pressure reducing valve and appurtenances. For additional requirements, see General Valve and Piping Arrangements in Vaults, in this section.
      - (c) Do not design a pressure reducing valve for direct buried service.
      - (d) Restrain all joints **per** see Standard Detail W/4.4.
  - b) Vault design.
    - (1) For pressure reducing valve sizes 12-inch and smaller diameter, see Standard Details W/4.2 and W/4.3.
    - (2) Top slab design for pressure reducing valve vaults.
      - (a) For 4-inch diameter pressure reducing valves, provide top slab with opening over valve; see Standard Details W/4.2, W/4.3 and W/5.23.
      - (b) For 6-inch to 12-inch diameter pressure reducing valves, provide opening over valve for valve removal, see Standard Details W/4.2, W/4.3 and W/5.22.
    - (3) Soil investigations for determining groundwater elevations must be provided at the location of the pressure reducing valve vault, see General Valve and Piping Arrangements in Vaults in the section.
    - (4) For pressure reducing valve sizes larger than 12-inch, see General Valve and Piping



Arrangements in Vaults in this section and requirements under WSSC Design Guideline 28-ME-DG-03, "Mechanical and Electrical Design Guidelines for Control Valves Vaults in the Water Distribution System that are to be Electrically Operated and Remotely Controlled".

c) Valves.

(1) Pressure reducing valve.

- (a) Provide 3-inch and larger pressure reducing valves with flanged ends and a pressure rating designed similar to gate valves (Class 125 or 250 valves); see Part One, Section 18 (Pipeline Valves). For smaller than 3-inch pressure reducing valves, provide threaded ends in accordance with National Pipe Threads (NPT).
- (b) Indicate on the Drawing the pressure reducing valve setting information, see Standard Detail W/4.4.

(2) Other Valves.

- (a) Provide gate valves on each side of the pressure reducing valve to be located in the vault, for maintenance or removal of the pressure reducing valve.
- (b) Provide bypass line with a closed gate valve around the pressure reducing valve. Typically the pressure reducing valve is located off the water pipeline and a gate valve is installed between the two branch connections of the pressure reducing valve.
- (c) Provide corporation stops on each side of the pressure reducing valve, in the vault, see Standard Details W/4.2 and W/4.3.

d) Access Openings.

(1) Equipment access opening for pressure reducing valves.

- (a) For 4-inch to 10-inch pressure reducing valves, provide an aluminum hatch in the top slab of the vault, see Standard Detail W/5.22 and W/5.23 for opening sizes.
- (b) For 12-inch pressure reducing valves, provide an aluminum hatch in the top slab of the vault see Standard Detail W/5.22 for opening size.
- (c) Locate the opening in the top slab of the vault directly over the center of the pressure reducing valve or as shown on Standard Detail W/5.22 and W/5.23. When two (2) pressure reducing valves are designed to be installed in the vault, provide an opening over the larger valve.

(2) Personnel access openings are to be located in the top slab of the vault in such a way that there are no obstructions to climb up and down the ladder steps.

- (a) Provide an aluminum hatch for personnel access, rated for H20 loading, see Standard Details W/4.2 and W/4.3, and Part Three, Section 16, (Design of Pipeline Structures).



- (b) If two pressure reducing valves are designed, provide opening located between the valves; see Standard Details W/4.2 and W/4.3.
- (3) Location of access openings, see General Valve and Piping Arrangements in Vaults in this section.
- e) Vault Location.
  - (1) Locate the vault as follows:
    - (a) Vault shall not be located in roadway.
    - (b) Vault access openings shall be within ten (10) feet of edge of the roadway or access driveway.
    - (c) Vault shall not be located in low areas (ditches, swales, etc.).
  - (2) Provide for vehicular access from street that will allow parking of maintenance vehicles.

**e. Flow Control Valves (FCV).**

- 1) WSSC will provide project specific requirements when the installation of a flow control valve.
- 2) For requirements, see Design Guideline WSSC-DG-03 (Mechanical And Electrical Design Guidelines For Control Valve Vaults In The Water Distribution System That Is To Be Electrically Operated And Remotely Controlled).

**f. Pressure Relief Valves (Relief Valve).**

- 1) WSSC will provide project specific requirements when the installation of a pressure relief valve and vault is necessary.
- 2) In most cases pressure relief valves are designed to protect the water pipeline against excessive pressure.
- 3) A pressure relief valve should be used for the following conditions:
  - a) When the water pipeline has a pressure reducing valve connection from a higher pressure zone.
  - b) At a water pumping station on the discharge side of the pumps.
- 4) Design pressure relief valves as follows:
  - a) Typically the discharge pressure setting of the pressure relief valve to open is ten (10) psi above the setting of the smaller pressure reducing valve.
  - b) Locations of the pressure relief valve should be designed hydraulically, so that the opening of the valve will occur relatively gradually to prevent pressure shock or water hammer conditions. Part of this design should include the distance between the pressure relief and pressure



reducing valves, to eliminate the possibility of pressure shock or water hammer conditions causing the other valve to activate. This condition may cause the two valves to start opening and closing due to drastic fluctuations in pipeline pressure. When the valves are designed to be hydraulically distant, the piping system itself can help dampen the pressure change seen by both valves.

- c) Number of pressure relief valves will depend on difference in high hydraulic grades (HHG) between the feeding pressure zone and the reduced pressure zones.
  - (1) When difference in high hydraulic grades is less than one hundred (100) feet or forty (40) psi, design a single pressure relief valve, see Standard Detail W/4.5.
  - (2) When difference in high hydraulic grades is over one hundred (100) feet or forty (40) psi and up to one hundred-fifty (150) feet or sixty-five (65) psi, design single pressure relief valve, Standard Detail W/4.5 or a dual pressure relief valve, Standard Detail W/4.7.
  - (3) When difference in high hydraulic grades is over one hundred-fifty (150) feet or sixty-five (65) psi design a dual pressure relief valve, see Standard Detail W/4.7.
- 5) Pressure relief valve and piping arrangements.
  - a) For pressure relief valve sizes 6-inch and smaller, see Standard Details W/4.5, W/4.7 and W/4.8. Indicate pressure relief valve settings on the drawings along with a profile view of the pressure relief discharge piping.
  - b) For pressure relief valve sizes larger than 6-inch, provide details on the drawings. Design the vault to house the pressure relief valve and appurtenances. For additional requirements, see General Valve and Piping Arrangements in Vaults in this section. Do not design the pressure relief valve for direct buried service.
  - c) Restrain all joint(s) on pressure relief piping and also provide thrust blocking on all fittings from the pressure relief valve to the flap valve.
  - d) Provide adequate cover over the pressure relief piping, see Part One, Section 4 (Selection of Pipe Material).
  - e) Piping Layout.
    - (1) See requirements under General Valve and Piping Arrangements in Vaults, in this section and the following requirements:
      - (a) For pressure relief valve sizes 6-inch and smaller diameter, see Standard Details W/4.5, W/4.7 and W/4.8.
      - (b) For pressure relief valve sizes larger than 8-inch, provide details on the drawings. Design the vault to house the pressure relief valve and appurtenances. For additional requirements, see General Valve and Piping Arrangements in Vaults, in this section.



f) Vault design.

- (1) For pressure relief valve sizes 6-inch and smaller diameter, see Standard Details W/4.5 and W/4.7.
- (2) Soil investigation for determining groundwater elevation must be provided at the location of the pressure relief valve vault, see General Valve and Piping Arrangements in Vaults in this section.
- (3) For pressure relief valve sizes larger than 8-inch, see General Valve and Piping Arrangements in Vaults in this section and requirements under WSSC Design Guideline 28-ME-DG-03, "Mechanical and Electrical Design Guidelines for Control Valves Vaults in the Water Distribution System that are to be Electrically Operated and Remotely Controlled".

g) Valve Design.

- (1) Pressure relief valve.
  - (a) Provide 3-inch and larger pressure relief valves with flanged ends and a pressure rating designed similar to gate valves (Class 125 or 250 valves), see Part One, Section 18 (Pipeline Valves).
  - (b) Indicate on the Drawing the pressure relief valve setting information; see Standard Detail W/4.8.
- (2) Provide corporation stops on the pressure side of the pressure relief valve in the vault; see Standard Details W/4.5 and W/4.7.

h) Access Openings.

- (1) Equipment access opening in the vault for pressure reducing valves:
  - (a) For single 6-inch and smaller pressure relief valve no equipment access opening is required, see Standard Detail W/4.5.
  - (b) For dual 6-inch and smaller pressure relief valves, provide equipment access opening over one of the pressure relief valves, see Standard Detail W/4.7.
  - (c) For larger than 8-inch pressure relief valve(s) design the equipment access opening in the top slab of the vault so that it is large enough to remove the pressure relief valve. Place the opening directly over the center of the pressure reducing valve. For dual pressure relief valves, the equipment access opening shall be large enough for both pressure relief valves.
- (2) Personnel access opening shall be located in such a way that there are no obstructions to climb up and down the ladder steps.
  - (a) Provide an aluminum hatch for personnel access, rated for H20 loading, see Standard Details W/4.5 and W/4.7, and Part Three, Section 16, (Design of Pipeline Structures).
- (3) Location of access openings, see General Valve and Piping Arrangements in Vaults in this section.



i) Vault location.

(1) Locate the vault as follows:

(a) The vault shall not be located in a roadway.

(b) Vault access openings shall be within ten (10) feet of edge of the roadway or access driveway.

(c) The vault shall not be located in low areas (ditches, swales, etc.).

(2) Provide for vehicular access from street that will allow parking of maintenance vehicles.

j) Discharge from the pressure relief valve.

(1) Design the discharge from the pressure relief valve to release to the atmosphere. Make adequate provisions to dispose of the discharged water.

(2) Under no circumstances shall the discharge piping be connected directly into a storm drain pipe or sanitary sewer pipe and/or any other type of storm drain or sanitary sewer structure (inlet, manhole, etc.).

(3) Provide a flap valve and end wall at the point of discharge, see Standard Detail W/4.6. A flap valve is a valve that will open automatically when water flow is in the pipeline.

(4) The discharge piping must drain by gravity from the pressure relief valve to the end wall.

(5) Include protection of the channel against erosion caused by the discharge of water from the pressure relief valve into an open channel, see Standard Details W/4.6 and W/4.7. If discharge point is located near a ditch, stream, etc., see Part Three, Section 9 (Pipeline Stream Crossings). Provide design calculations showing that the stream and channel have the capacity to handle the volume of discharged water without causing downstream flooding, erosion or damage.

**g. Swing Check Valves.**

1) In most cases, check valves are used when the design requires an automatic valve to prevent backflow. However they are not adequate to prevent backflow of contaminated water or potable water from another system into the WSSC water system.

2) Check valves are mainly used in water pumping stations. The location of the check valve should be on the discharge side of the pumps to control the water pressure in the pipeline when the pumps are off and thereby preventing water from flowing back through the pumps.

3) Check valves can also be designed for use at the connection point between two different pressure zone pipelines. In this case, when the higher pressure zone pipeline pressure drops below the lower pressure zone pipeline, the check valve will open and allow water from the lower pressure zone to flow into the higher pressure zone. When the higher pressure zone goes back to the normal higher pressure, the check valve will close.



- 4) Determine the appropriate location for the check valve and submit. After location is determined, WSSC will provide the required sizes and the type of check valve to be used.
- 5) Check valve and piping arrangements.
  - a) Design a vault to house the check valve and appurtenances, for additional requirements, see General Valve and Piping Arrangements in Vaults, in this section.
  - b) Do not design the check valve for direct buried service.
  - c) Equip check valves with a lever and weight for controlling the operation of the valve. No spring operated check valves will be permitted.
  - d) Access Opening.
    - (1) Provide an equipment access opening in the top slab of the vault, directly over the center of the check valve. Provide an opening large enough to allow for removal of the check valve.
    - (2) Provide a personnel access opening in the top of the slab of the vault, located in such a way that there are no obstructions to climb up and down the ladder.

**h. Backflow Preventers.**

- 1) Backflow preventers are required when the design has a direct connection between the WSSC water system (potable) and other water systems or equipment containing water or unknown substances, including but not limited to the following:
  - a) Fire sprinkler service connection
  - b) Fire hydrant meter
  - c) Irrigation system
  - d) Commercial and industrial connections
- 2) See requirements for installing and testing backflow preventers in The Plumbing Code.
- 3) During the design, determine if a backflow preventer **is required** to be installed.

**i. Butterfly Valves.**

- 1) WSSC will determine if the design requires the use of butterfly valves in lieu of gate valves and will provide design requirements. Typically, butterfly valves are not permitted.
- 2) See requirements under Design Guideline 28-ME-DG-03, "Mechanical and Electrical Design Guidelines for Control Valves Vaults in the Water Distribution System that are to be Electrically Operated and Remotely Controlled".





**j. Eccentric Plug Valves.**

- 1) In most cases, plug valves are used as the bypass valve in altitude valve vaults and in some cases for pressure reducing valve vaults.
- 2) Plug valves can be used for direct buried service, see Part One, Section 18 (Pipeline Valves).
- 3) The plug rotates and has a passageway or port through it. The plug valve requires a one-quarter turn to move from the fully open to fully closed position. Plug valves may be used for throttling the flow of water through the pipeline.
- 4) WSSC will determine if the design requires the installation of plug valves.
- 5) Determine the appropriate location for the plug valve and submit design for approval.
- 6) Plug valve and piping arrangements.
  - a) Design a vault to house the plug valve and appurtenances. For additional requirements, see General Valve and Piping Arrangements in Vaults, in this section. For information on using plug valves for direct buried service, see requirements for gates valves, Part One, Section 18 (Pipeline Valves).
  - b) Eccentric plug valves shall have the plug stored in the upper quadrant of the valve body when the valve is fully open. The plug would then have to rotate downward to close. Show on the drawing the location of the plug seat when closed on the drawings.
  - c) Orient the plug so that the seat is opposite the high pressure side of the piping when in the closed position.
  - d) Access Opening.
    - (1) Provide an equipment access opening in the top slab of the vault directly over the center of the plug valve. The opening must be large enough to allow for removal of the plug valve.
    - (2) Provide a personnel access opening in the top slab of the vault in such a way that there are no obstructions to climb up and down the ladder or manhole steps. If the design requires two (2) parallel valves and piping, provide the opening between the valves.
  - e) Piping Layout.
    - (1) For requirements for vault piping when using eccentric plug valves, see gate valves, Part One, Section 18 (Pipeline Valves). Also see altitude and pressure reducing valves, in this section.
    - (2) The ends of the plug valves are to have flanged ends for vault installation and mechanical joint ends for direct burial installation.



**k. Line Stop.**

- 1) Line stops provide a way to insert a temporary plug into an existing water pipeline through a tapping tee, stopping the flow of water to facilitate repairs, maintenance or connections.
- 2) When shutdowns are determined to be impossible, line stops can be designed to temporarily shut down the existing water pipeline; see the Specification for requirements. Special thrust restraint will be required to restrain the line stop; see Part Three, Section 27 (Thrust Restraint Design for Buried Piping).
- 3) **If Designer determines that the design requires the installation of line stop, submit to WSSC for approval**



## 23. Blowoff Connections.

### a. Design Requirements for Blowoff Connections.

- 1) Blowoff connections are required for the following water pipeline sizes:
  - a). For 16-inch and larger pipelines, see Type “A” and Type “B” Blowoffs.
  - b). For 6-inch and smaller pipelines, see Type “C” Blowoff.
- 2) Locate all blowoffs for pipelines 16-inch and larger, including fire hydrants designed as blowoffs, as close as possible to an existing/proposed sanitary sewer manhole to allow for the disposal of the chlorinated water into the sanitary sewer.
- 3) Do not use PVC AWWA C900 for Blow-off piping.
- 4) Under no circumstances shall the blow-off line connect directly to a storm drain pipe or sanitary sewer pipe and/or any type of storm drain or sanitary sewer structure (inlet, manhole, etc.).
- 4) For blowoff manhole requirements for minimum and maximum depths, see the guidelines in Part Two, Section 18 (Manhole Depth Design).
- 5) For information on setting the manhole frame and cover, see Part One, Section 16 (Design of Structures).
- 6) Verify that the location of blowoff manholes and valves as shown on the Standard Details is suitable for the proposed design. If the location is not suitable, provide notes and dimensions on the drawings for modifying the Standard Details to show the location of the manhole off the mainline pipe, see Part Three, Section 6, (Modifications to Specifications and Standard Details).

### b. Types of Blowoff Connections.

- 1) Type "A" blowoffs are designed so that a hose or a pump can be connected to the blowoff and can be discharged directly into a sanitary sewer manhole. This design provides versatility for the collection and disposal of the discharged chlorinated water.
  - a) For 16-inch to 30-inch diameter water pipelines there are two options for draining the pipeline.
    - (1) If the mainline pipeline is located within a roadway, design the blowoff to be a fire hydrant. For design requirements for fire hydrant settings and spacing, see Part One, Section 24 (Fire Hydrants). Verify that the fire hydrant will fully function to the Fire Marshall's standards, and design the connection as a Type "A" blowoff. When fire hydrants are designed as blowoffs, they serve a dual purpose and offer economy in design.
    - (2) In all other areas, design Type "A" blowoffs, as shown in Standard Detail W/3.0. This connection consists of a 6-inch branch from the mainline pipeline which drains into a blowoff manhole, allowing the water level in the pipeline to be drained by gravity to the invert elevation of the 6-inch connection at the mainline pipeline.



- b) For 36-inch and larger diameter water pipelines, design Type "A" blowoffs, as shown in Standard Detail W/3.02. This connection consists of a 6-inch branch that is rotated down forty-five (45°) degrees at the mainline pipeline, which then drains into the blowoff manhole, allowing the water level in the pipeline to be drained completely.
  - 2) Type "B" blowoffs are designed to discharge directly into a stream or channel, when the stream or channel has the capacity to handle the volume of discharged water without causing any downstream flooding, erosion, or damage and there are no environmental restrictions prohibiting the discharge of the chlorinated water. Contact MDE for permit restrictions, before incorporating a Type "B" blowoff into the design.
    - a) For 16-inch to 30-inch diameter water pipelines designed using Type "B" blowoffs, see Standard Detail W/3.04. This connection consists of a 6-inch branch connection from the main, which discharges directly into a stream or channel. This type of blowoff will not allow the pipeline to be drained completely by gravity; it only allows the pipeline to drain down to the elevation of the discharge point at the endwall.
    - b) For 36-inch and larger diameter water pipelines designed using Type "B" blowoffs, see Standard Details W/3.03 and W/3.04. This connection consists of a 6-inch branch that is rotated down forty-five (45°) degrees at the mainline pipeline, and drains either into a manhole or to an endwall. This type of blowoff will allow the water level in the pipeline to be drained completely when it is drained into the manhole. This design includes a Type "A" connection for greater versatility when dewatering and chlorinating.
    - c) When a Type "B" blowoff cannot be provided either due to environmental restrictions or stream or channel limitations, design the blowoff as a Type "A" blowoff.
  - 3). Type "C" blowoffs are designed for 6-inch and smaller pipelines that are not looped or connected to another pipeline (dead end mains). This connection is designed for flushing smaller diameter pipelines and consists of a 4-inch connection with a 2-1/2" fire hose connection; see Standard Details W/3.07 and W/3.08.
    - a) Design the connection a maximum **fifteen (15)** feet from the cap or plug on the mainline pipeline.
    - b) **Do not locate Type "C" Blowoff in sidewalks or driveways (if possible).**
    - c) **For non-traffic areas use Type "C" Blowoff Standard Detail W/3.07 and for traffic areas use Type "C" Blowoff Standard Detail W/3.08.**
- c. Blowoff Connection to the Mainline Pipeline.**
- 1) **For** blowoff connections for pipelines 20-inch and smaller, use a tee connection.
  - 2) **For** blowoff connections for pipelines 24-inch and larger, design the connection as a welded-on connection. Center the welded-on connection on a twenty (20) foot length of pipe, with both ends of the pipe section having the same elevation. In some cases, the welded-on connection can be designed so that the blowoff connection is closer to the end of the twenty (20) foot length of pipe; see requirements for welded-on connections in Part One, Section 7 (Allowable Fittings).



**d. Drawing Requirements for Blowoffs.**

- 1) On plan drawings, show the blowoff piping, the pipeline stations of the mainline pipeline, and reference the Standard Detail number.
- 2) On profile drawings, show the fitting sizes, station and invert elevation of the mainline pipeline and reference the Standard Detail number.
  - a) Locate the blowoff connections:
    - (1) For 16-inch to 30-inch mainline pipelines at or near each well-defined low point along the pipeline alignment.
    - (2) For 36-inch and larger mainline pipelines locate at each well-defined low point along the pipeline alignment.
  - b) For Type "B" blowoffs also provide on the drawings a 1" = 10' scale profile showing fitting types and sizes, invert elevations, and a note stating "For additional blowoff details, see Standard Detail W/3.04".
- 3) Provide earth cover requirements for blowoff piping if the depth to the invert is greater than the following. Provide the blowoff piping valves in a manhole or vault and show details on the drawings for the valves to be designed in the manhole or vault.
  - a) Water pipelines 16-inch to 30-inch, if the depth to invert of the mainline pipeline is greater than (twenty-one) 21 feet.
  - b) Water pipelines 36-inch and larger, if the depth to invert of the mainline pipeline is greater than fifteen (15) feet.



## 24. Fire Hydrants.

### a. General Requirements.

1) Information to be shown on the drawings.

a) Type of Fire Hydrant.

{1} Standard Fire hydrant. Label as FH.

{2} High Traffic Fire Hydrants. Label as High Traffic FH.

b) Elbow elevation (E.E.). Provide the elevation of the fire hydrant base elbow. The lead pipe from the outlet of the fire hydrant tee to the fire hydrant base should be laid level.

c) Length of the fire hydrant barrel. Provide the length of the barrel from the elbow elevation to the bury line (finished grade or existing ground). Base the length of the barrel on increments of 6-inches. Submit the tabulation sheet, showing the computations supporting the design of the fire hydrant barrel lengths.

(1) The minimum length of the barrel shall be four and one half (4-1/2) feet, based on maintaining four (4) feet of cover over the pipeline.

(2) Adjust the fire hydrant tee to obtain the correct elbow elevation at the fire hydrant.

(3) The maximum length of the barrel shall be eight (8) feet. If additional length is required, provide a call out on the drawings, indicating the barrel length of eight (8) feet and the length of extension needed. Fire hydrant barrel extensions are available in increments of 6-inches, starting at 6-inches long.

c) Provide a call out indicating the nearest existing fire hydrant(s) on the drawings.

### b. Type of Fire Hydrants

1) Standard fire hydrants.

2) High traffic fire hydrants.

a) When fire hydrants is located in dual or more lane roadways or when WSSC indicates the need.

b) On single lane roadways within thirty (30) feet of the edge of roadway for dual or more lane roadways.

c) When roadway does not have curbs.



**c. Fire Hydrant Settings (Horizontal).**

- 1) Within a roadway with curbs, place fire hydrants two (2) feet behind the face of the curb, see Standard Detail W/8.0.
- 2) Within an open-section roadway without curbs, place fire hydrant twelve (12) feet beyond the limit of stabilized shoulder or pavement or as shown on the drawing, see Standard Detail W/8.1.
- 3) In other areas, submit locations for fire hydrants **for WSSC approval**.
- 4) When spacing the fire hydrants along a roadway, see the following requirements:
  - a) Locate the fire hydrant to maximize access for fire department equipment and personnel.
  - b) At street intersections, locate the fire hydrant at the curvature or truncation of the roadway property line fillet, whenever possible.
  - c) Locate the fire hydrant at the intersection of the property line and the roadway right of way or property line.
  - d) When the mainline pipeline is 16-inch to 30-inch diameter and within a roadway, the fire hydrant can be designed as a blowoff connection, see Part One, Section 23 (Blowoff Connections).
  - e) **Fire hydrants shall not be located within ten (10) feet of a sewer main, sewer house connection or storm drain.**
- 5) Fire hydrant facing note. In accordance with the Specifications, the placement of the fire hydrant stream outlet is normally set facing toward the street line when the mainline water pipeline is located in the street. If the mainline water pipeline is located out of the roadway, either behind the curblines or at edge of roadway, provide a note on the drawings. "Set the stream outlet of the fire hydrant facing the curb or edge of roadway".

**d. Fire Hydrant Leads.**

- 1) Provide a minimum 6-inch diameter fire hydrant lead pipe between the tee and the fire hydrant elbow, unless the fire hydrant base connection is different.
- 2) Determine the mainline pipeline size (to which the hydrant is connected) for fire flow conditions. The minimum mainline diameter allowable is 8-inches.
- 3) Design the length of the fire hydrant lead pipe between the fire hydrant tee and the fire hydrant as short as possible. Restrain all joints on the fire hydrant lead; see Standard Details B/2.1 and B/2.2.
- 4) All piping for the fire hydrant lead shall be DIP minimum Class 54.
- 5) **Do not use PVC AWWA C900 for fire hydrant lead.**



- 6) No bends, offsets, etc., shall be located between the fire hydrant tee and the fire hydrant elbow. **If bends are needed submit to WSSC for approval.**
- 7) In the vertical plane, the fire hydrant lead must be laid level. Profiles for fire hydrant leads will be required for the following cases:
  - a) When the fire hydrant lead crosses other buried utilities except when the mainline water pipe profile shows that the crossing utilities will provide the fire hydrant lead with sufficient clearances.
  - b) When the grade/ground line is not the same as the mainline pipe. (Changes in grade due to ditches, distances from mainline pipeline, etc.).
- 8) Do not design blocking for fire hydrant tees. Restrain all pipe between the tee and the fire hydrant, see Part Three, Section 27 (Thrust Restraint Design for Buried Piping).
- 9) When PVC is used for the mainline piping, connect the tracer wire to the fire hydrant base elbow; see Standard Details W/8.0 and W/8.1.

**e. Fire Hydrant Spacing.**

- 1) Single family residential areas. Provide five hundred (500) feet maximum spacing between fire hydrants, as measured along an improved roadway, and a maximum fire hydrant coverage of four hundred (400) feet from the nearest fire hydrant to any dwelling as measured along an improved roadway (as a fire engine would drive).
- 2) Townhouses and garden apartments. Provide two hundred fifty (250) to three hundred (300) feet maximum spacing between fire hydrants, as measured along an improved roadway, and a maximum fire hydrant coverage of three hundred (300) feet from the nearest fire hydrant to any dwelling as measured along an improved roadway (as a fire engine would drive).
- 3) All other areas (commercial, industrial, high-rise, elevator type apartments, etc.). Provide two hundred fifty (250) to three hundred (300) feet maximum spacing between fire hydrants, as measured along an improved roadway. Conform to any additional requirements of the Fire Marshall for fire hydrant spacing.





## 25. Water Service (House) Connections (WHC).

### a. General Requirements.

- 1) The requirements for designing WHCs include determining the WHC type (i.e. individual or double connection, private site utility system (on-site), or right of way connection), the location of the WHC, the location and type of meter setting (i.e. outside with single or double meter settings or inside meters) and the size for the WHC(s).
- 2) Water meters 1-1/2-inch to 12-inch in size are considered large meters. Contact WSSC to determine the location for all large meters, i.e. inside or outside the dwelling/building. Also, see the requirements for WSSC water meters in The Plumbing Code.
- 3) Show the WSSC permit numbers for the WHCs on the drawings for each lot on the plan view at the location of the WHC; WSSC will provide the permit information upon submission of the valid application at the permit center.
- 4) For new WHC's connections show the permit number or WHC's connections that are to be abandoned, show the abandonment permit number.

### b. Operating Pressures for WHCs.

- 1) For 2-inches and smaller WHC, maximum operating pressure is one-hundred and thirty (130) psi.
  - a) Only when approved by WSSC, the maximum operating pressure can be increased to a limit of one-hundred and thirty-five (135) psi.
- 2) For 3-inch and larger WHC, maximum operating pressure is one-hundred and thirty (130) psi.
  - a) When approved by WSSC for a higher maximum operating pressure, the following must be included:
    - (1) All gate valves must be Double Disc Valves; see Part One, Section 18 (Pipeline Valves).
    - (2) An on-site pressure reducing valve vault must be designed; see Part One, Section 22 (Specialty Valves).

### c. Types of WHCs.

- 1) Individual Connections.
  - a) For all inside meter settings, use individual connections.
  - b) For outside meter settings, when approved by WSSC.
    - (1) For meter sizes 1-1/2-inch and larger, use individual connections.
    - (3) For meter size 1-inch and smaller try to design the connections as double connections, see requirements below for double connections for outside meter settings.



2) Double Connections for Outside Meter Settings.

- a) Where individual connections have been specified or approved by the WSSC, provide all residential dwellings or buildings which require a 1-inch or smaller meter with double outside meter settings, see Standard Details W/5.15 and W/5.15a. Exceptions include situations where there are an odd number of WHCs.

(1) Do not use double connections for inside meter settings.

- b) Double connections shall be designed such that the water service for each dwelling or building is hydraulically equivalent to providing each dwelling or building with an individual WHC. The WHC between the water main and the double meter setting shall be sized accordingly.
- c) Double WHCs between the water main and the double meter setting are typically 2-inch in diameter and smaller, see Standard Details W/5.15 and W/5.15a.
- d) Multi-unit arrangements such as "Piggy Back", "Back to Back" or other cluster development arrangements are not entitled to a WHC per unit.

3) Private site utility system (on-site) system connections.

- a) Private site utility system (on-site) connections are required for water service to private property having a large water demand. (i.e., commercial, industrial, schools, apartments, etc.)
- b) Private site utility system (on-site) connections are typically 4-inch in diameter and larger.

4) Right of way connections.

- a) Right of way WHCs are permitted for individual connections using inside meter settings only, unless otherwise **approved by** WSSC.
- b) Right of way connections are typically 2-inch in diameter and smaller.

**d. Size of WHCs.**

- 1) Indicate the size of the WHCs in the General Notes.
- 2) **For all new residential services provide 1-1/2-inch WHC.**
- 3) Size all other types of WHCs for the type of development being served; see The Plumbing Code or **Development Service Code**. The WHC must conform to the requirements set forth by WSSC.

**e. Allowable Pipe Material for WHCs.**

- 1) For WHCs 2-inch in diameter and smaller, design the pipe material to be copper in accordance with the Specifications.
- 2) For WHCs 3-inch in diameter and larger, design the pipe material as DIP in accordance with the



Specifications. **Do not design WHC using PVC AWWA C900.**

**f. Horizontal WHC Alignment.**

1) WHCs 2-inch and smaller.

- a) Locate WHCs to readily serve the existing/proposed dwelling/building in a cost-effective manner. Specify the horizontal location of the WHC based on the guidelines in this Section.
- b) Minimum spacing between WHC is two (2) feet and when parallel, if possible.**
- c) Show the WHCs from the mainline pipe connecting to front of the property, dwelling, or building and within the roadway right of way. See WSSC Standard Details W/5.10 and W/5.11 for installation of water house connections with inside meters and Standard Details W/5.13 and W/5.14 for installation of outside meters. If the design will not allow the WHC to be installed in the front of the property, submit a request for a variance with justification for changing the WHC location requirements.
- d) Design WHCs to be 5'-0" clear horizontally from permanent structures and other utility appurtenances (such as storm drain inlets, street light poles, transformers, etc.) and adjacent parallel piping with the exception of Sewer House Connections (SHC) as indicated below.
- e) When both WHCs and SHCs are required, locate both house connections according to WSSC Standard Detail M/18.0 and the clearance requirements under Part Three, Section 3 (Pipeline Crossings and Clearances) and as follows:
  - (1) For individual WHCs, design WHC and SHC to be in the same trench, **when practical.**
  - (2) For double WHCs, locate the WHC at the property line between the two properties to be served, and locate the SHC in separate trenches according to the design guidelines in Part Two, Section 27, and (Sewer House Connections).
- e) Provide the following information on the drawings for 2-inch and smaller WHCs.
  - (1) Show the WHCs for outside meters, from the mainline water pipeline to the limits shown in Standard Details W/5.6, W/5.7, W/5.8, W/5.9, W/5.15 and W/5.15a. For WHCs with inside meters, show the WHC to the property line or as stated otherwise in the General Notes. The WHCs locations shall be as follows:
    - (a) Individual WHCs. Locate individual WHCs for inside or outside meter settings, where practical, ten (10) feet downgrade from the center of the property being served and if possible, no closer than ten (10) feet from the property line.
    - (b) Double WHCs. Locate WHCs for double outside meter settings at the property line between the two properties being served by the connection. When designing double WHCs, take into consideration the location of telephone, cable, and electric appurtenances, which maybe located at the property line between lots within the Public Utility Easement (PUE) or Public Improvement Easement (PIE).



2) WHCs 3-inch and larger.

- a) The location of WHCs for private site utility system (on-site) systems is based on the design of the private site utility system (on-site) system.
- b) The design of WHCs 3-inch and larger will be typical to a small diameter mainline water pipeline; see Part One for the design requirements for water pipelines and include thrust restraint as required; see Part Three, Section 27, (Thrust Restraint Design for Buried Piping).
- c) Coordinate the location for private site utility system (on-site) services with WSSC.
- d) Provide the following information on the drawings for WHCs 4-inch and larger:
  - (1) Connect the WHCs to the water pipeline in accordance with Standard Detail W/5.12.
  - (2) For thrust restraint, see Part Three, Section 27, (Thrust Restraint Design for Buried Piping) and Standard Detail W/5.12.

3) Terminating WHCs.

- a) WHCs 2-inch and smaller, with Inside Meter Settings.
  - (1) WHCs for inside meter settings shall terminate at the property line with a curb stop see Standard Details W/5.10 and W/5.11. See requirements below for locating curb stops:
    - (a) The curb stop must not be located within a curb or gutter section.
    - (b) Avoid locating the curb stop within a sidewalk, driveway, or any other paved surface.
  - (2) On tertiary streets, if the right of way limit ends at the edge of the roadway paving or at the curb or gutter lines, extend the WHCs to the limit of the Public Utility Easement (PUE) or Public Improvement Easement (PIE). In this case, provide the WSSC with a right of way for the WHC.
- b) For WHCs 2-inch and smaller, with Outside Meter Settings.
  - (1) Terminate WHCs for outside meter settings as indicated in Standard Details W/5.6, W/5.7, W/5.8, W/5.9, W/5.15 and W/5.15a.
  - (2) On tertiary streets, if the right of way limit ends at the edge of the roadway paving or at the curb or gutter lines, extend the WHCs to the limit of the Public Utility Easement (PUE) or Public Improvement Easement (PIE). In this case, provide the WSSC with a right of way for the WHC and the outside meter setting and show the location of the meter setting on the drawings.
- c) For WHCs 3-inch and larger. Extend the WHC to the property line or as shown in Standard Detail W/5.12, and terminate with a plug or cap.



**g. Vertical WHC Alignment.**

- 1) Depth of cover for WHCs.
  - a) DIP WHCs. Provide a minimum of four (4) feet of cover over the WHC. See requirements for designing DIP water pipelines under Part One, Section 11 (Vertical Alignment – Profiles).
  - b) Copper Pipe WHC. Provide a minimum of three and one half (3-1/2) feet of cover over the WHC, unless otherwise noted on the drawings, see the Standard Details and Specifications.
- 2) Vertical Alignment of the WHCs.
  - a) DIP WHC. Design the DIP WHC to be laid level and provide invert elevations on the drawings at the property line, unless a profile of the alignment is provided, see Standard Detail W/5.12 for connection and layout details. If the vertical alignment cannot be laid level or if the WHCs crosses other utilities, drainage ditches or changes in grade, provide a profile on the drawings, see requirements under Part One, Section 11 (Vertical Alignment – Profiles).
  - b) Copper Pipe WHC. Design the copper WHC level with the top of the water mainline pipeline, except at the corporation stop and as follows:
    - (1) At the property line, provide four (4) feet of cover over the WHC; see Standard Details W/5.10, W/5.11, W/5.13 and W/5.14.
    - (2) If the roadway layout has ditches or storm drains, special design information is required on the drawings. Include a note in the General Notes referencing Standard Detail W/5.11, W/5.13 or W/5.14 as applicable. Provide WHC lowering information for the crossing of the proposed utilities and ditches, see “Copper pipe WHC lowering at storm drains and other utility crossings” in this section.
    - (3) If site grading is to be performed following installation of the WHCs and the contractor will be unable to install the WHCs with the minimum cover as noted above, provide invert elevations of the WHCs.
    - (4) If the WHC cannot be installed within the depth requirements noted above for reasons of utility crossings or a deep design for the water pipe, provide invert elevations for the WHC. Give the invert elevations at the mainline water pipeline, at the curb stop or plug and at every vertical grade change on the WHC.
    - (5) Copper pipe WHC lowering at storm drains, proposed or existing ditches and other utility crossings. When the minimum cover requirements noted above for copper WHCs cannot be maintained, the following information is required on the drawings:
      - (a) Show the station of the WHC at the mainline water pipe, the name of the crossing utility or ditches and the distance or span of the WHC that requires lowering as referenced from the property line or other survey controls.



- (b) Show the invert elevation of the WHC at the utility crossing; see Sketch "J" and Part Three, Section 3 (Pipeline Crossings and Clearances).

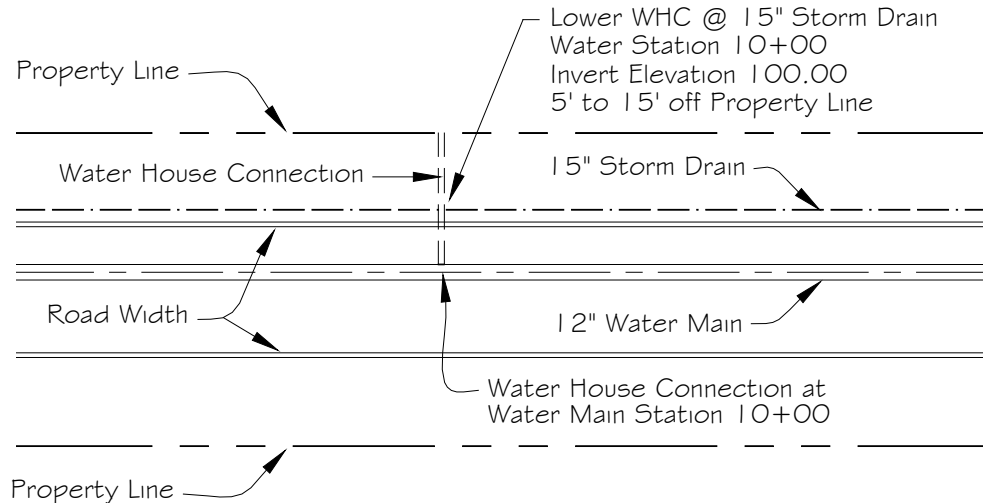

### SKETCH "J"

WHC Lowering at Storm Drains and Other Utility Crossings

#### h. Location of Outside Meters.

##### 1) For 2-inch and smaller meters.

- a) Design WHCs for 2-inch and smaller meters to accommodate outside meter settings, unless otherwise approved by WSSC.
- b) Avoid locating the outside meter setting within sidewalks, driveways, or any other paved surfaces. The preferred location of the outside meter setting is adjacent to a sidewalk in a level grass area within the **public** road right of way and outside of traffic bearing areas, see Standard Details W/5.10, W/5.11, W/5.13, and W/5.14.
- c) The outside meter settings shown in Standard Details W/5.6, W/5.7, W/5.8, W/5.9, W/5.15 and W/5.15a are for non-traffic bearing areas only. If the design requires a meter setting to be located in a traffic bearing area, WSSC approval of the location is required, and special design details are also required on the drawings for a traffic bearing meter setting.
  - (1) **For replacement of existing 2-inch meters with existing on-site piping is 2-inch, see Standard Detail W/5.9a.**
- d) Locate outside meters within the roadway right of way according to Standard Details W/5.13, and W/5.14, and the following:
  - (1) For closed paving sections (with curb and gutter), the outside meter setting shall be centered



- in the grass area between the back of the sidewalk and the property line as shown in Standard Detail W/5.13. If there is no grass area between the sidewalk and the property line, then locate the meter setting in the sidewalk and provide a note on the plans to indicate the location.
- (6) For open paving sections (without curb and gutter), locate the outside meter setting as shown in Standard Detail W/5.14.
  - (7) On open or closed section tertiary streets, if the right of way limit ends at the edge of the roadway paving or at the curb or gutter lines, locate the meter setting outside of traffic bearing areas at a location approved by the WSSC. Provide WSSC with a right of way for the WHC and the outside meter setting.
  - (5) Provide WSSC with a right of way if the meter setting must be located outside of the road right of way on private property. In such cases, the outside meter settings can be located within Public Improvement Easements (PIEs).
  - (6) Provide 5'-0" minimum horizontal clearance between the meter setting and all permanent structures such as storm drain inlets, street light poles, other utility appurtenances and pipelines except when WHC is installed in a combined trench with the SHC.
  - (7) Provide 10'-0" minimum horizontal clearance between the outside meter setting and trees.
- e) Provide the following meter location information on the drawings for 2-inch and smaller meters:
- (1) Show the location of the outside meter setting for each lot on the drawings as an approximate 1/8-inch diameter circle with the letter "M" inside of the circle as shown in Standard Detail M/1.0 and indicate the elevation for each meter frame and cover as follows:
    - (a) Existing areas or areas outside of the limits of grading, design the meter frame and cover to be flush with the existing grade.
    - (b) Proposed or future grading areas, design the elevation of the meter frame and cover to be flush with the finished grade.
  - (2) For outside meter settings, include a General Note on the drawings which specifies the meter setting location(s); see Standard Details W/5.13 and W/5.14.
  - (3) If the meter setting is located other than as shown in the Standard Details, provide the centerline outside meter setting stakeout information on the drawings.
- 2) For 3-inch and larger meters (FM, Compound and Ultrasonic Meters).
- a) Coordinate the location of 3-inch and larger meters with WSSC (inside or outside the dwelling/building), see the requirements for WSSC water meters in The Plumbing Code.
    - (1) For Outside Meters, locate the meter in a vault, as shown in Standard Details W/5.0, W/5.0a, W5.0b, W/5.0c, and W/5.0 d, W/5.0e, W/5.0f, W/5.0 g, W/5.0 h, W/5.0.i, W/5.1, W/5.1a,



W/14.0, W/14.0a, W/14.0b and W/14.0c. Do not modify the Standard details for meter vaults. Locate outside meters within an accessible grass area within the public right of way. The meters shall not be located in low areas, roadways, sidewalks, driveways or any other paved areas. If a location meeting these criteria is not available within the public right of way, then the meter shall be located within an accessible grass area on property within a right of way. The vault shall be located so the meter can be made readily accessible. The location shall be approved by WSSC.

- (a) Provide WSSC with a right of way if the meter setting must be located outside of the road right of way on private property. In such cases, the outside meter settings can be located within Public Improvement Easements (PIEs).
  - (b) Provide 5'-0" minimum horizontal clearance between the meter vault and all permanent structures such as storm drain inlets, street light poles, and other utility appurtenances.
  - (c) Provide 10'-0" minimum horizontal clearance between the outside meter setting and trees.
  - (d) If the outside meter is located in a paved area, provide frame and cover instead of hatches and provide remote reading device, see Standard Detail W/5.0e.
- 3) For replacement of outside existing Detector Check Meters.
- a) Locate the detector check meter in a vault, as shown in Standard Details W/12.0, and W/12.0a. Do not modify the Standard details for meter vaults. Locate outside meters within an accessible grass area within the public right of way. The meters shall not be located in low areas, roadways, sidewalks, driveways or any other paved areas. If a location meeting these criteria is not available within the public right of way, then the meter shall be located within an accessible grass area on property within a right of way. The vault shall be located so the meter can be made readily accessible. The location shall be approved by WSSC.
    - (1) Provide WSSC with a right of way if the meter setting must be located outside of the road right of way on private property. In such cases, the outside meter settings can be located within Public Improvement Easements (PIEs).
    - (2) Provide 5'-0" minimum horizontal clearance between the meter vault and all permanent structures such as storm drain inlets, street light poles, and other utility appurtenances.
    - (3) Provide 10'-0" minimum horizontal clearance between the outside meter setting and trees.
    - (4) If the outside meter is located in a paved area, provide frame and cover instead of hatches and provide remote reading device, see Standard Detail W/5.0e.

**i. Connection of the WHC to the Mainline Pipeline.**

- 1) For WHCs 3-inch and larger, see Standard Detail W/5.12.
- 2) For WHCs 2-inch and smaller, design the WHCs to connect to a 16-inch diameter or smaller





mainline.

- a) Variance may be given on the mainline water size requirement for 24-inch and smaller diameter, exceptions require WSSC approval. For mainline water larger than 24-inch diameter WHCs are not allowed.
- b) Design the connection with a corporation stop at the mainline pipeline and the following requirements:
  - (1) Maintain a minimum distance of 1'-6" between WHC taps on the mainline pipeline.
  - (2) Use of service saddles in accordance with the specifications is required on the mainline pipeline as follows:
    - (a) If the mainline pipeline is 4-inch and smaller DIP.
    - (b) If the mainline pipeline is 6-inch through 12-inch DIP with WHCs larger than 1-inch diameter.
    - (c) For all PVC mainline pipelines.

**3) Connecting WHC to existing PCCP pipelines, see Standard Detail W/13.1.**

**j. Insulated Joints on WHCs.**

- 1) Insulating Joints on WHCs 2-inch and smaller in accordance with Standard Detail C/3.5 will be required for the following conditions:
  - a) Existing CIP and DIP with no polyethylene encasement.
  - b) Existing DIP with bonded joints.
  - c) Existing DIP with special exterior coatings.
- 2) Insulating Joints on WHCs 3-inch and larger in accordance with Standard Detail C/3.1 will be required for the following conditions:
  - a) Existing DIP with bonded joints.
  - b) Existing DIP with special exterior coatings.





# PART TWO

# Sewer Design Guidelines

## PART TWO

### SEWER DESIGN GUIDELINES

#### **General.**

Part Two of the Pipeline Design Manual covers the minimum standard design criteria to be followed when preparing the design of sewer pipelines and appurtenances within the Washington Suburban Sanitary District (WSSD). Use this part in conjunction with Part One, Water Design Guidelines and Part Three, Common Design Guidelines. Although this manual is intended as a guideline, it is the Designer's responsibility to review and verify the applicability of all material presented herein as it pertains to the specific project under design.

The portions of the sewer system, which are considered as the property and responsibility of the WSSC, are the sewer pipelines, appurtenances and those portions of the sewer service connections which lie in public right of way and in right of ways granted to the WSSC. All other systems are in most cases, the responsibility of the respective property owner(s).

For projects that are constructed and maintained by WSSC, WSSC will indicate the size and limits of the sewer pipeline(s) and appurtenances to be designed and constructed. The WSSC Design Criteria for Sewer Distribution Systems are found in Two, Appendix C.

In the preparation of the contract documents, the Designer will take into full account such matters as environmental impact, public impact including maintenance of pedestrian and vehicular traffic, maintenance of existing and proposed utility services, constructability, and system maintenance to produce the most cost-effective design.



## TABLE OF CONTENTS

### PART TWO - SEWER DESIGN GUIDELINES

<b>1. Terminology and Abbreviations</b>	<b>S - 1.1</b>
a. General.	S - 1.1
b. Type of Pipelines.	S - 1.1
c. WSSC Documents.	S - 1.1
d. Pipe Material.	S - 1.1
e. Miscellaneous.	S - 1.2
<b>2. Pipeline Sizes and Materials. (Gravity Sewers)</b>	<b>S - 2.1</b>
a. General.	S - 2.1
b. Minimum Pipe Size.	S - 2.1
c. Hydraulic Design for Sewer Pipelines.	S - 2.1
d. Allowable Pipe Material.	S - 2.1
e. Allowable Pipe Joints.	S - 2.1
f. Special Pipe.	S - 2.2
<b>3. Selection of Pipe Material (Gravity Sewers).</b>	<b>S - 3.1</b>
a. General.	S - 3.1
b. Selection of Pipe Material.	S - 3.1
c. Selection of Pipe Class and Wall Thickness.	S - 3.3
d. <b>Special Applications.</b>	<b>S - 3.4</b>
<b>4. Fittings.</b>	<b>S - 4.1</b>
a. <b>General.</b>	<b>S - 4.1</b>
b. Bends.	S - 4.1
c. Tees, Wyes and Saddles on Mainline Sewers for Sewer <b>Service</b> Connections (SHC).	S - 4.1
d. Bends and Wyes on Mainline Sewers for Drop Manhole Connections.	S - 4.1
e. Stoppers, Caps and Plugs.	S - 4.1
f. Other Fittings.	S - 4.2
g. DIP Fittings.	S - 4.2
<b>5. General Horizontal Alignment.</b>	<b>S - 5.1</b>
a. General.	S - 5.1
b. Considerations.	S - 5.1
c. Location.	S - 5.1
d. Labeling New Pipelines and Structures in Plan.	S - 5.2
e. Sewage Flow Tabulation Table.	S - 5.2
f. Connections to Existing Sewer Pipelines and Manholes.	S - 5.2
g. Determining Existing Pipe and Manhole Material.	S - 5.3
h. Labeling Existing Pipelines and Manholes in Plan.	S - 5.4
i. Labeling Existing Structures in Plan.	S - 5.4
j. Connection to Proposed or Future Pipelines.	S - 5.4



<b>6. Curved Horizontal Alignment.</b>	<b>S - 6.1</b>
a. General.	S - 6.1
b. Sewers 24-inch and Smaller Diameter.	S - 6.1
c. Sewers 27-inch and Larger Diameter.	S - 6.1
<b>7. Relocating Sewer Pipelines.</b>	<b>S - 7.1</b>
a. General.	S - 7.1
b. Design Requirements.	S - 7.1
c. Alignment - Horizontal and Vertical.	S - 7.1
d. Thrust Restraint for Force Mains.	S - 7.2
e. Abandonment.	S - 7.3
<b>8. Vertical Alignment (Profiles).</b>	<b>S - 8.1</b>
a. Cover Over Pipeline.	S - 8.1
b. Labeling Pipeline in Profile.	S - 8.4
c. Profile Grade Lines.	S - 8.4
d. Length of Profile.	S - 8.5
e. Pipeline Stationing.	S - 8.6
<b>9. Vertical Alignment - Pipe Slope.</b>	<b>S - 9.1</b>
a. General.	S - 9.1
b. Minimum Pipe Slopes.	S - 9.1
c. Maximum Pipe Slopes.	S - 9.2
d. Steep Pipe Slopes to Flatter Pipe Slopes.	S - 9.2
<b>10. Tunnels or Casing Pipes.</b>	<b>S - 10.1</b>
a. Requirements.	S - 10.1
b. Size of the Pipeline in the Tunnel or Casing Pipe.	S - 10.1
c. Installing Casing Pipes for Existing Sewer or Force Mains	S - 10.1
<b>11. Design of Structures.</b>	<b>S - 11.1</b>
a. Manholes.	S - 11.1
b. Special Design Structures.	S - 11.1
c. Design of Structures on Profiles.	S - 11.1
d. Horizontal Location of Manholes.	S - 11.1
e. Vertical Location of Manholes.	S - 11.1
f. Diameter of Frames and Covers.	S - 11.2
g. Setting of Frames and Covers.	S - 11.2
h. Labeling Manholes on the Drawings.	S - 11.3
i. Infiltration - Sewerage Structures.	S - 11.3
<b>12. Types of Manholes.</b>	<b>S - 12.1</b>
a. General.	S - 12.1
b. Types of Manholes.	S - 12.1
c. Labeling Manholes on the Drawings.	S - 12.1



<b>13. Manhole Spacing.</b>	<b>S - 13.1</b>
a. Location.	S - 13.1
b. Maximum Spacing Between Manholes.	S - 13.1
c. Minimum Spacing Between Manholes.	S - 13.1
<b>14. Pipe to Manhole Geometry.</b>	<b>S - 14.1</b>
a. General.	S - 14.1
b. Minimum Diameter Precast Manholes for Maximum Sewer Sizes.	S - 14.1
c. Minimum Diameter of Existing Brick Manholes for Maximum Sewer Sizes.	S - 14.1
d. Determining Manhole Diameter.	S - 14.2
e. Offset Manholes.	S - 14.4
f. Mechanical Flow Control Devices in Manholes.	S - 14.4
g. Non-Circular Manholes.	S - 14.4
h. Special Pipe Openings in Manholes.	S - 14.5
<b>15. Pipe Slope and Manhole Distance.</b>	<b>S - 15.1</b>
a. Design.	S - 15.1
b. High Velocities in Pipelines.	S - 15.3
c. Pipe Slope 10% to 35%.	S - 15.3
d. Pipe Slope Greater Than 35%.	S - 15.4
<b>16. Manhole Drop Connections.</b>	<b>S - 16.1</b>
a. General.	S - 16.1
b. Design Requirements.	S - 16.1
c. Design Considerations.	S - 16.2
d. Special Designs.	S - 16.3
<b>17. Manhole Channel Design.</b>	<b>S - 17.1</b>
a. General.	S - 17.1
b. Channel Slope.	S - 17.1
c. Radius of the Channel.	S - 17.5
d. Width of Channel.	S - 17.5
e. Channels for 36-inch and Larger Diameter Sewers.	S - 17.5
f. Top of Bench Elevation.	S - 17.6
g. Width and Slope of the Top of the Bench.	S - 17.6
<b>18. Manhole Depth Design.</b>	<b>S - 18.1</b>
a. General.	S - 18.1
b. Precast Concrete Manholes.	S - 18.1
c. Existing Brick Manholes.	S - 18.2
<b>19. Manholes Built Over Existing Sewers.</b>	<b>S - 19.1</b>
a. General Requirements.	S - 19.1
b. Design Requirements.	S - 19.1
<b>20. Fall Prevention Systems.</b>	<b>S - 20.1</b>
a. General Requirements.	S - 20.1
b. Design Requirements for Deep Manholes.	S - 20.1



<b>21. Adjusting Manhole Frames and Covers.</b>	<b>S - 21.1</b>
a. General.	S - 21.1
b. Adjusting Existing Precast Concrete Manholes.	S - 21.1
c. Adjusting Existing Brick Manholes.	S - 21.1
d. Adjusting Existing Cast in Place Manholes.	S - 21.1
<b>22. Impact of Storm Water Facilities on Existing Sewers.</b>	<b>S - 22.1</b>
a. General.	S - 22.1
b. Coordination.	S - 22.1
c. Requirements for Impact Assessment.	S - 22.1
<b>23. Relief Sewer Design.</b>	<b>S - 23.1</b>
a. Interaction of Relief Sewer with Existing Sewer.	S - 23.1
b. Flow Distributions.	S - 23.1
c. Junction Chambers, Structures or Manholes.	S - 23.3
d. Horizontal Alignment.	S - 23.4
e. Vertical Alignment.	S - 23.3
f. Design Flows for Both Systems.	S - 23.4
g. Hydraulic Design of Relief Sewers.	S - 23.4
<b>24. Force Main Design.</b>	<b>S - 24.1</b>
a. Alignment - Horizontal and Vertical.	S - 24.1
b. Profile Requirements.	S - 24.1
c. Allowable Pipe Material and Fittings.	S - 24.2
d. Appurtenances and Structures.	S - 24.5
e. Hydraulic Design of Force Mains.	S - 24.6
f. Hydraulic Transients	S - 24.9
f. Field Testing Requirements for Force Mains.	S - 24.11
g. Required Analysis for Hydrogen Sulfide (H <sub>2</sub> S) Generation and Release.	S - 24.11
<b>25. Grinder Pump, Pressure Sewer System.</b>	<b>S - 25.1</b>
a. General.	S - 25.1
b. Design Requirements.	S - 25.1
c. Appurtenances and Structures.	S - 25.4
d. Horizontal and Vertical Alignment.	S - 25.5
e. Required Analysis for Hydrogen Sulfide (H <sub>2</sub> S) Generation and Release.	S - 25.6
f. Industrial or Commercial Developments.	S - 25.6
g. Abandonment of Existing Pressure Sewer.	S - 25.6
h. Connecting to Existing Pressure Sewer.	S - 25.7
i. Connecting Pressure Sewer House Connection (PSHC) into a Gravity Sewer	S - 25.7
j. Shutdown of Existing Pressure Sewer.	S - 25.7
<b>26. Air Valves.</b>	<b>S - 26.1</b>
a. General.	S - 26.1
b. Design Requirements.	S - 26.1
c. Type and Piping Configuration.	S - 26.1
d. Design of Air Vacuum Valves and Air Release Valves.	S - 26.2



<b>27. Sewer Service Connections (SHC).</b>	<b>S - 27.1</b>
a. Type of Service Connections.	S - 27.1
b. Allowable Pipe Material for SHC.	S - 27.1
c. Size of SHC.	S - 27.1
d. Connection of the SHC to the Mainline Sewer.	S - 27.1
e. Connection of the SHC to a Manhole.	S - 27.2
f. Horizontal Alignment.	S - 27.3
g. Vertical Alignment.	S - 27.4
<b>28. Hydrogen Sulfide (H<sub>2</sub>S) Control.</b>	<b>S - 28.1</b>
a. General.	S - 28.1
b. Analysis for Hydrogen Sulfide Generation.	S - 28.1
c. Selection of Pipe and Structure Material.	S - 28.3
d. Additional Design Considerations to Mitigate Hydrogen Sulfide Generation and Release.	S - 28.3

### CHARTS

<b>Chart "B"</b>	Flow-Slope Relationship as a Guide to Sulfide Forecasting, Effective BOD of 300 mg/L.	S - 28.2
------------------	--	----------

### SKETCHES

<b>Sketch "K"</b>	Fittings on Sewer Pipelines with Different Inside Diameters.	S - 4.2
<b>Sketch "L"</b>	Labeling Manholes or Vaults on Proposed or Finished Grades.	S - 11.3
<b>Sketch "M"</b>	Labeling Manholes or Vaults on Existing Grades.	S - 11.3
<b>Sketch "N"</b>	Manhole Diameter to Pipe OD.	S - 14.2
<b>Sketch "O"</b>	Existing Manhole Diameter to Pipe OD.	S - 14.3
<b>Sketch "P"</b>	Offset Manhole.	S - 14.4
<b>Sketch "R"</b>	Pipe Manhole Connection for Steep Grades.	S - 14.5
<b>Sketch "S"</b>	Determining Pipe Length Between Manholes for Sewer Pipelines 48" and Larger.	S - 15.2
<b>Sketch "T"</b>	Pipe Slope 10% or Greater.	S - 15.4
<b>Sketch "U"</b>	Angles Between Pipes 12" and Smaller Entering Manholes	S - 17.2
<b>Sketch "V"</b>	Manhole Channel Design, Matching Crown Elevations.	S - 17.3
<b>Sketch "W"</b>	Manhole Channel Design, Matching Crown Elevations, Exception.	S - 17.4
<b>Sketch "X"</b>	Minimum Radius of Manhole Channel.	S - 17.5
<b>Sketch "Y"</b>	Relief Sewer - Flow Control Device (Weir).	S - 23.2
<b>Sketch "Z"</b>	Determining SHC Invert Elevation at Mainline Sewer.	S - 27.7





**TABLES**

<b>Table "10"</b>	Minimum Curve Radius for 27-inch and Larger RCP Sewer Pipelines.	S - 6.1
<b>Table "11"</b>	Minimum Pipe Slopes.	S - 9.1
<b>Table "12"</b>	Diameter Requirements for Manhole Frames and Covers.	S - 11.2
<b>Table "13"</b>	Maximum Manhole Spacing.	S - 13.1
<b>Table "14"</b>	Minimum Diameter Precast Manholes for Maximum Sewer Sizes.	S - 14.1
<b>Table "15"</b>	Minimum Diameter Existing Brick Manholes for Maximum Sewer Sizes.	S - 14.1
<b>Table "16"</b>	Angles Between Pipes 12-inch and Smaller Entering Manholes and Minimum Drop Across Channel Inverts.	S - 17.2
<b>Table "17"</b>	Wall Thickness for Depth of Brick Manholes.	S - 18.2
<b>Table "18"</b>	Minimum Curve Radius for PVC and HPDE Pressure Sewers.	S - 25.5
<b>Table "20"</b>	Minimum Curve Radius for PVC and HPDE Force Mains.	S - 24.4



## 1. Terminology and Abbreviations:

The following terms and abbreviations are used in Part Two of the Design Manual.

### a. General.

<b>WSSC</b>	Washington Suburban Sanitary Commission.
<b>WSSD</b>	Washington Suburban Sanitary District.
<b>ASTM</b>	American Society for Testing and Materials.
<b>AWWA</b>	American Water Works Association.
<b>ANSI</b>	American National Standards Institute.
<b>AISI</b>	American Iron and Steel Institute.
<b>AASHTO</b>	American Association of State Highway and Transportation Officials.
<b>DIPRA</b>	Ductile Iron Pipe Research Association.
<b>MDE</b>	Maryland Department of the Environment.
<b>MSHA</b>	Maryland State Highway Administration.

### b. Type of Pipelines.

<b>Lateral or Branch Sewer</b>	Gravity Sewer pipeline designed and constructed to convey wastewater from the house/dwelling to the Collector Sewer.
<b>Collector Sewer</b>	Gravity Sewer pipeline designed and constructed to convey wastewater from Lateral or Branch Sewers to the Outfall or Trunk Sewer.
<b>Outfall Sewer or Trunk Sewer</b>	Gravity Sewer pipeline designed and constructed to convey wastewater from a series of Collector Sewers to the Interceptor Sewer.
<b>Interceptor Sewer</b>	Gravity Sewer pipeline (large diameter) designed and constructed to convey wastewater from a series of Outfall or Trunk Sewers to a wastewater treatment plant.
<b>Force Main</b>	Pressure Sewer pipeline designed and constructed to convey wastewater from a pumping station to the Gravity Sewer.
<b>Pressure Sewer</b>	Pressure Sewer pipeline designed and constructed to convey wastewater from single grinder pump to the Lateral or Branch Sewers

### c. WSSC Documents.

<b>SEP</b>	<b>System Extension Process.</b>
<b>DRP</b>	<b>Developer Relocation Projects</b>
<b>Specifications</b>	WSSC General Conditions and Standard Specifications.
<b>Standard Details</b>	WSSC Standard Details for Constructions.
<b>Drawings</b>	Contract design drawings.
<b>Plumbing Code</b>	WSSC Plumbing and Fuel Gas Code.

### d. Pipe Material.

<b>DIP</b>	Ductile Iron Pipe
<b>CIP</b>	Cast Iron Pipe
<b>PCCP</b>	Prestressed Concrete Cylinder Pipe



<b>PVC</b>	Polyvinyl Chloride (Sewer Pipe)
<b>PVC (AWWA C900 or C905)</b>	Polyvinyl Chloride (Water Pipe)
<b>ACP</b>	Asbestos Cement Pipe
<b>CISP</b>	Cast Iron Soil Pipe
<b>RCP</b>	Reinforced Concrete Pipe
<b>HDPE</b>	High Density Polyethylene

**e. Miscellaneous.**

<b>psi</b>	pounds per square inch.
<b>ID</b>	Pipe inside diameter.
<b>OD</b>	Pipe outside diameter.
<b>HGL</b>	Hydraulic grade line.
<b>R/W</b>	<b>Public Road</b> Right of Way.
<b>PIE</b>	Public Improvement Easement.
<b>PUE</b>	Public Utility Easement.
<b>SHC</b>	Sewer <b>Service (House)</b> Connection.
<b>WHC</b>	Water <b>Service (House)</b> Connection.



## 2. Pipeline Sizes and Materials. (Gravity Sewers)

### a. General.

- 1) Standard pipe materials. Ensure that all designs allow for the use of materials that conform to all applicable sections of the Specifications and the Standard Details.
- 2) Special pipe materials. Submit any special design features and/or special materials required due to the specific nature of the contract for approval to WSSC prior to being incorporated into the contract documents. If approved, it will be for the specific case in question and not a general approval for use elsewhere (other contract documents). Special Provisions to the Specifications and special details on the drawings may be required.

### b. Minimum Pipe Size.

- 1) Minimum 8-inch diameter for mainline sewer pipelines.
- 2) Minimum of 4-inch diameter for SHCs.

### c. Hydraulic Design for Sewer Pipelines.

- 1) Provide some reserve capacity when designing the pipe sizes. Do not design the sewer pipeline to flow completely full at the design flow rate, see Appendix C (WSSC Design Criteria for Sewer Systems).
- 2) For sewer pipelines over 12-inch, submit hydraulic calculations in support of the sewer design.
- 3) For existing sewer pipelines larger than 15-inch diameter, review as-builts and request information on existing flow conditions before designing connections to the sewer pipeline. In some areas, the existing sewer pipeline was designed to be surcharge.

### d. Allowable Pipe Material.

- 1) See Part Two, Section 3 (Selection of Pipe Material (Gravity Sewers)).

### e. Allowable Pipe Joints.

- 1) Polyvinyl Chloride Pipe (PVC) with bell gasket joints per ASTM F477.
- 2) Reinforced Concrete Pipe (RCP) with bell gasket joints per ASTM C443.
- 3) Ductile Iron Pipe (DIP), see requirements under Part One, Section 3 (Pipe and Fitting Joints).
- 4) Polyvinyl Chloride Pipe AWWA C900, see requirements under Part One, Section 3 (Pipe and Fitting Joints).
- 5) For additional requirements, see Specifications and the Standard Details.



**f. Special Pipe.**

- 1) Determine the type of pipe that will be required. If the design requires a non-standard (special) pipe material, submit all necessary calculations and data supporting the design change to WSSC **for approval**.
- 2) Examples of special pipe: Non-Float Pipe, Reinforced Concrete Pipe (RCP) other than ASTM C76, etc.
- 3) For more information, see Part Two, Section 3 (Selection of Pipe Material (Gravity Sewers)).



### 3. Selection of Pipe Material (Gravity Sewers).

#### a. General.

- 1) This Section discusses pipe material for gravity sewers and SHCs, for force mains, see Part Two, Section 24 (Force Mains) and for pressure sewer systems, see Part Two, Section 25 (Grinder Pump, Pressure Sewer Systems).
- 2) When pipelines are to be designed near or within Maryland Transit Administration (MTA) Rail Lines, see Part Three, Section 3 (Pipeline Crossings and Clearances) and Part Three, Section 26 (Tunnels Design Criteria).
- 3) The amount of allowable cover is determined using the highest profile grade/ground line shown on the profile.
- 4) Do not change the type or class of pipeline material between manhole sections.
- 5) Indicate in the General Notes the following:
  - a) Size and type of the gravity sewer pipeline.
  - b) For RCP, DIP or PVC AWWA C900, indicate the pipe class designation on the profile defining the limits of pipe class designation and the limits of each type of pipe material.
  - c) For DIP and fittings, specify **zinc basecoat applied to pipe surface and asphaltic topcoat, and must have V-Bio encasement**, see Part One, Section 2 (Pipe Materials and Fittings) and special interior lining in accordance with the Specifications.
  - d) For PVC AWWA C900 with ductile iron fittings, specify polyethylene encasement, see Part One, Section 2 (Pipe Materials and Fittings) and special interior lining following the Specifications.
- 6) When designing RCP, use Wall C dimensions for determining pipe OD.
- 7) When DIP or PVC AWWA C900 is required, verify the pipe diameter and capacity.
  - a) DIP or PVC AWWA C900, is not available in the same pipe sizes as RCP and **PVC ASTM D3034** sewer pipe.

#### b. Selection of Pipe Material.

- 1) Sewer House Connections (SHC), 4-inch or 6-inch diameter.
  - a) Polyvinyl Chloride Pipe (PVC) meeting ASTM D3034, SDR 35 or SDR 26.
  - b) Polyvinyl Chloride Pipe (PVC AWWA C900) and Ductile Iron Pipe (DIP) the SHC must be of the same as mainline sewer.
- 2) Mainline Gravity Sewers.



- a) Polyvinyl Chloride Pipe (PVC), 8-inch through 15-inch diameter, meeting ASTM D3034, SDR 35 and 18-inch through 27-inch diameter meeting ASTM F679, thickness T-1.
- b) Polyvinyl Chloride Pipe (PVC AWWA C900). Use PVC AWWA C900 for the following conditions:
  - (1) For sewer pipelines on steep slopes for sewers twelve (12) inches and smaller, see Part Two, Section 16 (Pipe Slope and Manhole Distance) and Standard Detail S/3.03.
  - (2) For sewer pipelines on steep slopes for sewers larger than twelve (12) inches, see Part Two, Section 15 (Pipe Slope and Manhole Distance) and Standard Detail S/3.03, and special designs and details must be provided; see Part Three, Section 6 (Modifications to Specifications and Standard Details).
  - (3) For sewer pipelines when the cover is over twenty-two (22) feet, see requirements on Standard Detail W/6.1.
  - (4) When horizontal and vertical separation between the water and sewer pipelines as stated in Part Three, Section 3 (Pipeline Crossing and Clearances) cannot be obtained.
- c) Closed Profile Polyvinyl Chloride Pipe (PVC), 21-inch through 48-inch diameter, meeting ASTM F1803.
- d) Open Profile Polyvinyl Chloride Pipe (PVC), 18-inch through 30-inch diameter, meeting ASTM F794.
- e) Reinforced Concrete Pipe (RCP), 21-inch and larger, meeting ASTM C76. Use RCP for the following conditions:
  - (1) Stream crossings of sewer pipelines; see Part Two, Section 8 (Vertical Alignment (Profiles)).
  - (2) Horizontal alignment requires the sewer pipeline to have a curved alignment, see Part Two, Section 6 (Curved Horizontal Alignment).
- f) Ductile Iron Pipe (DIP), see Part One, Section 2 (Pipe Material and fittings) and 4 (Selection of Pipe Material).
  - (1) All DIP to have exterior zinc basecoat applied to pipe surface and asphaltic topcoat, and must have V-Bio encasement with special interior lining, see Specifications
  - (2) For sewer pipelines on steep slopes, see Part Two, Section 15 (Pipe Slope and Manhole Distance) and Standard Detail S/3.03, and special designs and details must be provided; see Part Three, Section 6 (Modifications to Specifications and Standard Details).
  - (3) When horizontal and vertical separation between the water and sewer pipelines as stated in Part Three, Section 3 (Pipeline Crossing and Clearances) cannot be obtained.
  - (4) Stream crossings of sewer pipelines; see Part Two, Section 8 (Vertical Alignment (Profiles)).



(5) For sewer pipelines when the cover is over twenty-two (22) feet.

**g) Special Materials.**

(1) For special projects or conditions, the use of pipe manufactured to industry standards other than those listed in the Specifications can be specified, examples are:

(a) Flow under highly surcharged conditions or **where** groundwater levels are excessive, reinforced concrete low-head pressure pipe might be considered.

(b) Areas where hydrogen sulfide may create corrosion problems, such as downstream from a pumping station or pressure sewer discharge, might require investigation of polyethylene-lined or fiberglass-lined DIP, T-Lock RCP, RCP with extra "sacrificial" concrete or other special protective linings.

**c. Selection of Pipe Class and Wall Thickness.**

1) Polyvinyl Chloride Pipe (PVC).

a) PVC sewer pipe meeting ASTM D3034, ASTM F679, ASTM F1083 or ASTM F794 as specified in the Specifications.

b) For backfill requirements see the Specifications and Standard Detail M/8.1c.

c) Maximum cover over the pipe in accordance with Standard Detail M/8.1c is twenty two (22) feet.

2) Polyvinyl Chloride Pipe (PVC AWWA C900).

a) Selection of pipe class/wall thickness for PVC AWWA C900 sewer pipelines is the same procedure as indicated for PVC water pipelines; see Part One, Section 4 (Selection of Pipe Materials).

b) Maximum cover over the pipe will depend on bedding and backfill requirements see Standard Detail W/6.1 for Dimension Ratio (DR) and allowable cover.

3) Ductile Iron Pipe (DIP). Selection of pipe class/wall thickness for DIP sewer pipelines is the same procedure as indicated for DIP water pipelines; see Part One, Section 2 (**Pipe Material and fittings**) and 4 (Selection of Pipe Materials).

4) Reinforced Concrete Pipe (RCP).

a) RCP meeting ASTM C76.

b) For the class of pipe for various depths of cover, see Standard Detail S/8.0.

c) For special conditions that differ from the conditions/criteria in the Specifications and Standard Details (for example, trench width exceeding the standard, depth of cover exceeding the standard, etc.) special analysis/calculations must be performed to arrive at the appropriate combination of pipe class/bedding. Generally, the design calculations follow the procedures in the American Concrete Pipe Association's Concrete Pipe Handbook and Concrete Pipe Design





Manual.**d. Special Applications.**

- 1) When the pipeline crosses under a railroad, verify with the Railroad Authority, the requirements for crossing its property or right of way.
- 2) When pipelines are to be designed within MSHA right of way for highways, design the pipeline as follows:
  - a) MSHA definition for types of highways (from MSHA Utility Policy, dated March 1998). Contact the MSHA for current guidelines.
    - (1) Expressways are divided highways, with full control of access, on which all crossroads are grade separations and all entrance and exit maneuvers are via interchange ramps. Expressways are primarily designed for high speed, long distance travel with unrestricted movement of traffic and no direct access to abutting properties.
    - (2) Controlled Access Highways are a higher class of highway and usually incorporate access control. Controlled access designations severely restrict the use of highway right of way for any purpose other than its primary function. Controlled access limits are denoted on MSHA drawings and plats by the words "Right of Way of Through Highway".
  - b) Requirements stated below are only for pipelines within MSHA's right of ways and are only general guidelines. Verify additional requirements with MSHA.
    - (a) Pipelines passing through MSHA's highways.
      - [1] All pipeline crossings must be in a sleeve, tunnel or have the class of DIP increased to the next higher class of pipe.
    - (b) Longitudinal occupancy by pipelines within MSHA's right of way for highways.
      - [1] Expressways. No longitudinal occupancy by new pipelines is permitted.
      - [2] Controlled Access Highways. Longitudinal occupancy is permitted by special exemption. During the design, obtain written exemption from MSHA.
      - [3] Roadways other than Expressways and Controlled Access Highways. Longitudinal occupancy is permitted; see MSHA Utility Policy, dated March 1998.
- 3) When pipelines are to be designed near or within Maryland Transit Administration (MTA) Rail Lines, see Part Three, Section 3 (Pipeline Crossings and Clearances) and Part Three, Section 26 (Tunnels Design Criteria).
- 4) When pipelines are to be designed near or within Marlboro Clay
  - 1) See requirements under Part 3, Section 19, Geotechnical Considerations for Crossing Pipeline Alignments.
  - 2) Design using DIP and restrain all joints at a minimum, see recommendations from



**Geotechnical Report.**



#### 4. Fittings.

##### a. General.

- 1) For fittings requirements, see Part One, Sections 2 (Pipe Materials and Fittings) and 7 (Allowable Fittings). All fittings to have special interior lining in accordance with the Specifications.

##### b. Bends.

- 1) Horizontal bends.
  - a) Not permitted on 24-inch and smaller diameter sewers.
  - b) On larger than 24-inch diameter sewers, may be used if approved by WSSC. Maximum horizontal bend deflection is 22-1/2° (degrees) or 1/16<sup>th</sup>.
- 2) Vertical bends on sewers are not permitted, except for drop connection at manholes and SHC drop connections.

##### c. Tees, Wyes and Saddles on Mainline Sewers for Sewer Service Connections (SHC).

- 1) SHCs on mainline sewers are only permitted on pipelines smaller than 15-inch diameter by use of tees, wyes or saddles; see Specifications and Standard Details S/6.0, S/6.1, S/6.2, S/6.3, S/6.3a, S/6.7 and S/6.8.
- 2) For fittings required on SHCs, see Specifications and Standard Details S/6.0, S/6.1, S/6.2, S/6.3, S/6.3a, S/6.7 and S/6.8.

##### d. Bends and Wyes on Mainline Sewers for Drop Manhole Connections.

- 1) For fittings and requirements for 8-inch through 12-inch sewer drop connections, see Standard Details S/3.1 and S/3.1a, and for 8-inch inside drop connections, see Standard Details S/3.1b and S/3.1c.
- 2) Drop connections on sewer pipelines larger than 12-inch, require approval from WSSC and modifications to Standard Details, see Part Two, Section 16 (Manhole Drop Connections) and Part Three, Section 6 (Modifications to Specifications and Standard Details).

##### e. Stoppers, Caps and Plugs.

- 1) Sewer pipelines with a diameter of 8-inch or greater shall be ended or terminated with a manhole or structure.
- 2) SHC(s) with a diameter of 6-inch or smaller shall be ended or terminated with a clean out or a manhole as applicable.
- 3) Sewer pipelines with a diameter of 8-inch or greater, terminated for future connection or extension, shall end with a manhole or structure and a one (1) foot capped stub.
- 4) Stoppers shall be used only to temporarily plug a sewer pipeline during construction.



- 5) In accordance with the specifications, a stopper can be either a cap or plug.
- 6) On the drawing provide a callout for a stopper.

**e. Other Fittings.**

- 1) See Standard Details and Specifications for fittings not listed above.

**f. DIP Fittings.**

- 1) If the design has been approved for use of ductile iron fittings, take into account the difference between the inside diameter (ID) of the fittings and the ID of DIP. The different inside diameter could cause problems with the building up of solids at the change in pipe diameter, see Sketch "K". Verify that the use of these fittings will not affect the design of the sewer pipeline.

**Example:**

42" DIP, Class 50, per AWWA C151: OD = 44.50"  
 Wall thickness = 0.47"  
 ID = 43.56"±

42" diameter DI fitting, per AWWA C110: OD = 44.50"  
 Wall thickness = 1.28"  
 ID = 41.94"±

The difference in diameter between the pipe and fitting equals 1.62"± (43.56 - 41.94). Divide it by two and the radius difference will be 0.81"± or 0.07'. The invert of the fitting will be 0.81" higher than the pipe and may provide a location for the build up of solids.

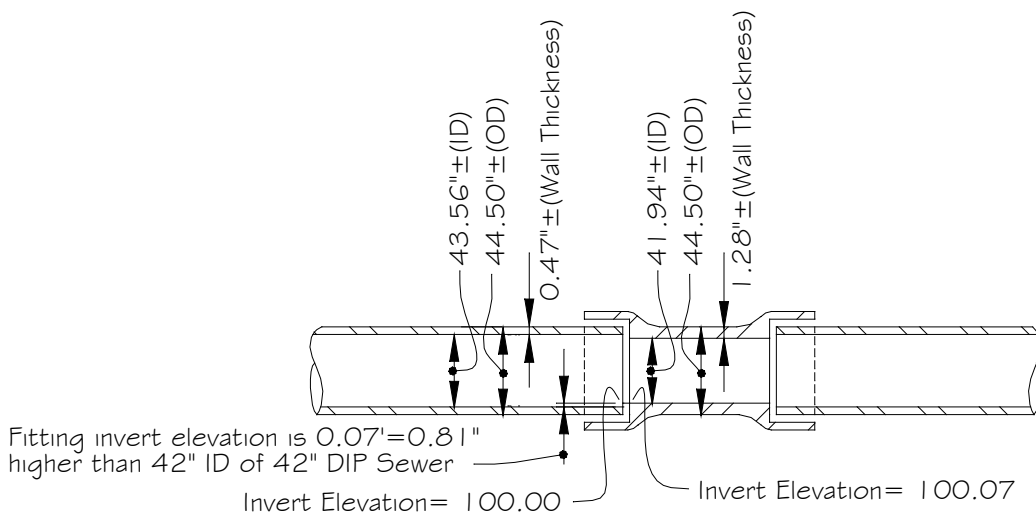

**SKETCH "K"**

Fittings on Sewer Pipelines with Different Inside Diameters



## 5. General Horizontal Alignment.

### a. General.

- 1) The Designer has the responsibility to point out where various factors of good planning and design are in conflict with the following guidelines and the requirements of other agencies. The alignment must be the best overall design. Failure to point out conflicts at an early stage in the design may result in delays and possibly costly changes.
- 2) If the design follows the guidelines in this manual, the design will most likely result in a plan that can be carried through to completion without delay.

### b. Considerations.

- 1) Identify and locate all existing and proposed facilities prior to selecting the alignment of the sewer.
- 2) Consider the guidance in Part Three, Section 19 (Geotechnical Considerations for Pipeline Alignments), when selecting the horizontal alignment.

### c. Location.

- 1) The horizontal alignment shall take into account the following general alignment guidelines, if practical. Pipelines larger than 12-inch in diameter may have other limitations and requirements that alter these general alignment guidelines.
  - a) Where practical, design the location of water pipeline as follows:
    - (1) For paving with twenty-four (24) feet and wider design seven (7) feet from the centerline road.
    - (2) For paving width less with twenty-four (24) feet, design five (5) feet from the centerline road.
    - (3) Avoid locating pipeline in High Volume Roadways if possible. If required, locate pipeline to have only one-lane closure.
    - (4) Locate pipeline within the existing or proposed pavement of proposed streets
  - b) Locate the pipeline on the lower higher elevation side of the street. Typically the water pipeline is located on the higher elevation side; see Part One, Section 8 (Horizontal Alignment) for locating water pipelines.
  - c) The pipeline alignment within existing areas (streets or roads) should avoid construction in high traffic volume roads and avoid road closings if possible.
  - d) In existing areas (streets or roads) the alignment of the pipeline should try to avoid the removal of trees or landscaped areas.
  - e) The pipeline alignment should be extended past the limits of the proposed road improvements



so that future pipeline extensions maybe constructed without the need to cut the pavement, if possible.

- f) When the pipeline alignment is located outside the road right of way, minimize disruption to environmental features and where possible avoid steep slopes, wetland areas, trees and other sensitive areas. Locate the alignment so that it follows the property lines as much as possible.
- g) Provide acceptable horizontal clearances for the proposed alignments where the existing mains are to remain in service. See Part Three, Section 3 (Pipeline Crossings and Clearances).
- h) When the existing or proposed pipelines will be installed in a casing pipe, see Part Two, Section 10 (Tunnels or Casing Pipes).
- i) For stream crossings, design the pipeline to be perpendicular to the stream crossing.
- j) Sewer pipelines are to be located to minimize disruption to environmental features. By necessity, sewers are located along drainage courses, where streams, wetlands, tree protection, etc., are likely to restrict the location of the pipeline. Take into account all permit restrictions and existing environmental features and avoid disturbance when possible.
- k) For additional horizontal alignment information, see Part Two, Section 4 (Fittings), Section 6 (Curved Horizontal Alignments), Section 7 (Relocating Sewer Pipelines), Section 10 (Tunnels or Casing Pipes) and Section 11 (Design of Structures).

**d. Labeling New Pipelines and Structures in Plan.**

- 1) Label all pipe sizes, pipe material/class, and direction of flow, appurtenances and fittings on plans.
- 2) Label manhole/structure in plan, give number, location and type of all structures; see Setting Frame and Covers under Part Two, Section 11 (Design of Structures). Start the numbering of the new manholes with the lowest number being the lowest point in the design and increase up grade from there.

**e. Sewage Flow Tabulation Table.**

- 1) Show Sewage Flow Tabulation Table on the first sheet. Include in this table, the number of units being served by this contract, type of units (existing, proposed, and/or future), the flow factor (gpd per unit), and the sewage flow.

**f. Connections to Existing Sewer Pipelines and Manholes.**

- 1) Extending existing sewer pipeline.
  - a) If the existing sewer pipeline material is one of WSSC's currently allowed materials (see Part Two, Section 3 (Selection of Pipe Materials- Gravity Sewers), specify the same pipe material and maintain the same horizontal and vertical alignment as the existing sewer pipeline.
  - b) Provide a note on the drawings stating "Connect and extend to existing <give existing pipe size



and existing pipe material> sewer and maintain the same horizontal and vertical alignment".

- c) If the existing sewer pipe material is not one of the WSSC's allowable pipe materials listed under Part Two, Section 3 (Selection of Pipe Materials - Gravity Sewers) and/or the horizontal or vertical alignment requires a change in direction, design the connection using a built-over manhole, see "Connecting to an existing sewer pipeline with a manhole" in this section and Part Two, Section 19 (Manholes Built Over Existing Sewers).
- 2) Connecting to an existing sewer pipeline with a manhole.
    - a) For design requirements see, Part Two, Section 19 (Manholes Built Over Existing Sewers).
    - b) Provide a note on the drawings stating "Build manhole over existing sewer". Also reference Standard Details S/2.0 and S/2.1 or S/2.2 for manhole design and S/3.01 for the manhole connection.
  - 3) Connecting to an existing manhole.
    - a) For design requirements, see Determining Manhole Diameters under Part Two, Section 14 (Pipe to Manhole Geometry).
    - b) Provide a note on the drawings stating "Connect to existing manhole". Also reference Standard Detail S/3.01 for the manhole connection.
  - 4) Asbestos Cement Pipe (ACP). When connecting to existing ACP pipelines, provide a detailed design and specifications on how this connection will be made. Refer to the Specifications and ASTM C966 for information on design and **connection to ACP**.

**g. Determining Existing Pipe and Manhole Material.**

- 1) Information that is available and items that is required to be developed.
  - a) WSSC "as-built" contract drawings are intended to show only the control reference ties to the horizontal location of the manholes, the type of pipe and manhole material used and the Contractor's name. Typically, **existing as-built drawings may not show field changes made during construction**. The Designer must investigate and determine if any changes have been made to the original design, and adjust the design accordingly.
  - b) Field surveys must follow the requirements set by WSSC. Perform all surveys required to design the alignment. Any survey information that is provided by WSSC from previous contracts, etc., must be verified and WSSC will not be responsible for this information.
  - c) Test pits are needed when the design requires the vertical and horizontal alignment to be accurately located. Request and perform test pits on the existing alignment so that the horizontal and vertical position can be accurately determined.
  - d) WSSC Contract Files can be requested from WSSC and the type of information that may be available in the contract files includes:
    - (1) WSSC Construction Inspector's field reports/notes.



- (2) WSSC/Contractors written correspondence
- (3) Contractor's shop drawings.

**h. Labeling Existing Pipelines and Manholes in Plan.**

- 1) Existing pipeline material; PVC, PVC AWWA C900/905, RCP, DIP, ACP, CISP, etc., and thickness class, type, grade, etc.
- 2) Existing WSSC contract number.

**i. Labeling Existing Structures in Plan.**

- 1) Indicate the existing manhole number, typical to new manhole numbering and labeling, as shown in Labeling Manholes on the Drawings under Part Two, Section 11 (Design of Structures), except above the line, note "Ex. MH", and below the line, include the manhole number.
- 2) Indicate the existing manhole material (precast, cast in place or brick) and contract number when designing the connection to the existing manhole. See requirements under Labeling Manholes on the Drawings, under Part Two, Section 12 (Type of Manholes).

**j. Connection to Proposed or Future Pipelines.**

- 1) If the new pipeline will depend on the construction of another pipeline for handling the flow of sewage, include a "Dependency Note" on the drawings. Indicate in the note that the new pipeline cannot be placed in service until another contract is in service; provide contract numbers of the depending pipeline.





## 6. Curved Horizontal Alignment.

### a. General.

- 1) Horizontal curves for sewer pipelines can only be used when a “must fit” situation occurs and the alignment is approved by WSSC during the preliminary design phase.

### b. Sewers 24-inch and Smaller Diameter.

- 1) Design with straight alignment (no curves) between manholes.

### c. Sewers 27-inch and Larger Diameter.

- 1) Design with straight alignment between manholes, unless the alignment **must** be designed with a horizontal curve, in accordance with the following criteria:

- a) The pipe in a horizontal curve must be RCP, PVC Closed Profile, PVC AWWA C905 or DIP.
- b) Set the curved alignment and determine the pipe material to be specified.
- c) After determining the curved alignment, provide data and computations on the curved pipe. For RCP, include recommendations for the design of the pipe joint from the manufacturer.

- 2) Allowable Pipe Material for Horizontal Curved Alignments.

#### a) Design Using RCP.

- (1) For RCP minimum design radius, see Table "10". This is based on twelve (12) foot lengths of straight pipe with a 3/8-inch joint opening. (For design purposes, the joint opening in Table "10" is based on eighty (80%) percent of the allowable joint opening in accordance with the Specifications.)

**TABLE "10"**

Minimum Curve Radius for 27-inch and Larger RCP Sewer Pipelines

Pipe Size	Minimum Radius	Pipe Size	Minimum Radius
27-inch	1072 feet	48-inch	1856 feet
30-inch	1184 feet	54-inch	2080 feet
33-inch	1296 feet	60-inch	2304 feet
36-inch	1408 feet	66-inch	2528 feet
42-inch	1632 feet	72-inch	2752 feet

- (2) RCP can be designed along a curved alignment without joint openings by using beveled or mitered joints. (i.e., using only the joint deflection of the bevel or miter and not allowing the opening of the joint). Angling the joints makes the curve.

- (a) The maximum angle allowed by WSSC is three (3°) degrees or less per bevel joint. Verify with the pipe manufacturer before designing the alignment.



- (b) To determine the allowable radius, contact the pipe manufacturer for pipe lengths. Using the longest pipe length provided by each pipe manufacturer and three ( $3^\circ$ ) degrees or less per bevel joint, determine the minimum allowable radius, see Formula "A", in Part One, Section 13 (Allowable Joint Deflections).
- (3) Consider the following prior to designing the curved pipeline alignment for RCP: availability and cost of manufacturing beveled joint verses straight pipe; hydraulic limitations, if any; and constructability (trenching, sheeting, pipe laying, etc.).
- b) Design twenty seven (27) - inch and larger DIP or PVC AWWA C900. For design guidelines using joint deflections, see Part One, Section 13 (Allowable Joint Deflections).
- c) Design Using PVC Closed Profile. The minimum allowable radius for PVC Closed Profile pipe is 372 feet. This is based on WSSC maximum allowable joint deflection for PVC Closed Profile pipe, which is two ( $2^\circ$ ) degrees, and a pipe length of thirteen (13) feet. Verify with the pipe manufacturer before designing the alignment.



## 7. Relocating Sewer Pipelines.

### a. General.

- 1) Take into account such matters as environmental impact, maintenance of pedestrian and vehicular traffic continuous service, maintenance of existing and proposed utility services, constructability, and system maintenance to produce the most cost effective design.
- 2) Consider the possible reduction in the pipeline capacity created by the sewer relocation. Alignment changes could result in a loss in capacity, including decreasing the pipe slope, adding pipe length and adding new manholes with sharply curved channels, which create head losses in the existing flow. Also, for larger diameter sewer pipelines, consider the future alignment location for a parallel relief sewer.
- 3) When the existing ground condition change due to grading, roadways, railways or etc. the existing water pipeline will have to be evaluated by WSSC Technical Services Group.
- 4) When another agency, utility, etc. is modifying the conditions over WSSC existing sewer pipeline and appurtenances, WSSC will have to review and approved such changes and may require the existing water pipeline and appurtenances to be relocated.
- 5) When relocating a Force Main, see requirements under, Part One, Section 10 (Relocating Water Pipelines).

### b. Design Requirements.

- 1) When relocating existing sewer pipelines, follow the requirements for sewer pipelines stated in this manual.

### c. Alignment - Horizontal and Vertical.

- 1) Take into consideration for the impact on all existing and proposed facilities before selecting the location of the relocated pipeline.
- 2) When selecting an alignment, take into consideration that the existing pipeline must be maintained and remain in service until the relocated pipeline is ready for final connection to the existing sewer.
- 3) Locate all the existing services and appurtenances (sewer house connections, sewer pipelines and manholes) that are connected to the existing pipeline.
- 4) Horizontal clearances.
  - a) Ensure acceptable horizontal clearances for relocated alignments where the existing mains are to remain in service until the relocation is complete.
  - b) For spacing between the existing and relocated sewer pipelines, see Part Three, Section 3 (Pipeline Crossings and Clearances).
  - c) For spacing between the existing and relocated force main pipelines, see requirement for water pipelines, Part One, Section 10 (Relocating Water Pipelines).



- d) Horizontal clearances between the existing and relocated force main pipelines may have to be increased when the relocated pipeline is within the zone of influence of the existing concrete blocking. To determine if there is adequate passive soil resistance, see Passive Soil Pressure for Concrete Thrust Blocks in Part Three, Section 27 (Thrust Restraint Design for Buried Piping).
- 5) Vertical clearances for relocated alignments must maintain a minimum of one (1) foot between pipe OD's (including any portion of the existing pipeline that will be abandoned by the relocation). For additional information, see Part Three, Section 3 (Pipeline Crossing and Clearances)
- 6) Connecting to existing sewers.
  - a) When the design requires the relocated sewer to be connected to an existing sewer, design the connection using a manhole.
  - b) Maintain service until the existing pipeline is abandoned; see Part Two, Section 19 (Manholes Built Over Existing Sewers).
  - c) For other requirements, see Connections to Existing Sewer Pipelines and Manholes, under Part Two, Section 5 (General Horizontal Alignment).
- 7) Connecting to existing manholes, see Connections to Existing Sewer Pipelines and Manholes, under Part Two, Section 5 (General Horizontal Alignment).
- 8) Relocating along the same sewer alignment. When the existing pipeline must be relocated in the same location and alignment, take into account the limitations for shutdown and the constructability of the sewer. This design will require the removal of the existing pipeline, a long shutdown time and require the contractor to pump around the relocated pipeline until it is placed in service.
- 9) SHCs on existing sewers. Maintain services on the existing pipeline until the relocated pipeline is ready for service. Transfer all existing SHCs to the new relocated pipeline, and then abandon the existing pipeline.
- 10) Contact WSSC for limitations on the shutdown of the existing sewer.
- 11) Locate all the existing services and appurtenances (sewer house connections, manholes, etc.,) that are connected to the existing pipeline.
- 12) For information on the design and location of structures and appurtenances, see Part Two, Section 12 (Design of Structures).

**d. Thrust Restraint for Force Mains.**

- 1) The design of the relocated alignment must not disturb existing blocking/thrust restraints on existing pipelines that are in service.
- 2) Provide thrust restraints for the relocated pipeline. If the shutdown time is limited, the design will require a thrust block for quick connections for restraining the relocated pipeline, so that



WSSC's customers are not out of service for an extended period, see Part Three, Section 27 (Thrust Restraint Design for Buried Piping).



**e. Abandonment.**

- 1) Show any abandonment of existing pipelines, structures and/or appurtenances on the drawings. Indicate the limits of abandonment and provide a description of what will be abandoned. The description shall also include **how** the abandonment will be performed, see requirements in the Specifications, Standard Details S/3.5 and S/3.6, and Part Three, Section 5 (Pipeline Abandonment).



## 8. Vertical Alignment (Profiles).

### a. Cover Over Pipeline.

- 1) Provide a minimum of three (3) feet of cover over sewer pipelines and SHCs, measured from the lowest profile grade or ground line, except at manholes, see Part Two, Section 19 (Manhole Depth Design).
- 2) Sewers over twenty (20) feet of cover. WSSC considers any sewer pipeline over twenty (20) feet of cover as a deep sewer.
  - a) Considerations for sewer pipelines over twenty (20) feet of cover.
    - (1) Pipe material.
      - (a) For sewer pipelines 12-inch and smaller, specify DIP or PVC AWWA C900 DR 14 pipe, see Standard Details W/6.0 and W/6.1.
      - (b) For sewer pipelines larger than 12-inches, specify DIP, **PVC AWWA C900** or RCP, see Part One, Section 3 (Selection of Pipe Material (Gravity Sewers)) and see **Standard Details W/6.0 and W/6.1.**
    - (2) Manholes.
      - (a) See Part Two, Section 18 (Manhole Depth Design) for diameter and fall prevention requirements.
      - (b) Design the alignment so that the manhole depth is less than twenty (20) feet or see the requirements under Part Two, Section 18 (Manhole Depth Design).
    - (3) Sewer House Connection (SHC), design the SHC out of the deep sewer area using one of the following:
      - (a) Re-locate the SHC to another area.
      - (b) Design parallel sewer to connect the SHC.
      - (c) Consider a Drop House Connection (DHC) for the SHC. See Part Two, Section 28 (Sewer House Connections (SHC)).
  - b) Additional considerations for sewer pipelines with twenty (20) to twenty-five (25) feet of cover.
    - (1) **Specify an additional easement** due to the excavation requirements for deep pipe; see Part Three, Section 2 (**Easements** and Construction Strips).
    - (2) Locate SHCs out of deep areas where possible.
    - (3) Choose a sewer alignment so that it is less **than** twenty (20) feet of cover or provide a special design.



- (a) Special designs include the following:
  - [1] Design parallel sewer for future use.
  - [2] Provide a casing around the sewer pipeline.
  - [3] For proposed developments, redesign the proposed grading to eliminate the deep sewers.
  - [4] Design the sewer to extend into another drainage area.
  - [5] Consider first floor service for specific cases.
  - [6] Design for pressure sewer systems.
- (4) Re-evaluate the site grading to eliminate deep sewers.
- (5) Evaluate proximity to existing utilities/structures
- c) Additional considerations for sewer pipelines with over twenty-five (25) feet of cover.
  - (1) Redesign the sewer alignment out of the deep area or provide a special design.
    - (a) Special designs include the followings:
      - [1] Design parallel sewer for future use.
      - [2] Provide a casing around the sewer pipeline.
      - [3] For proposed developments, design the proposed grading to eliminate the deep sewers.
      - [4] Design the sewer to extend into another drainage area.
      - [5] Consider first floor service only.
      - [6] Design for pressure sewer systems.
    - (2) **Specify an additional easement** due to the excavation requirements for deep pipe; see Part Three, Section 2 (**Easements** and Construction Strips).
    - (3) Re-evaluate the site grading to eliminate deep sewers.
    - (4) Evaluate proximity to existing utilities/structures.
  - 3) Pipelines crossing under a stream (water crossings), channels and ditches.
    - a) **General**
      - (1) Crossing a stream with a sewer pipeline, design the pipe material as DIP for smaller than 21-inch sewer pipelines and DIP or RCP for 21-inch and larger sewer pipelines.





- (2) For RCP, label in profile and include in the General Notes the pipe class required and minimum lay length of twelve (12) feet. For design of pipe class for RCP, see Part Two, Section 3 (Selection of Pipe Material - Gravity Sewers).
- (3) Show invert/bottom elevation of the crossing stream, ditch, etc on the profile.
- (4) When designing the horizontal and vertical alignment at stream crossings, the designer should try to minimize the number of pipeline stream crossings, take into account stream meandering and maintain a minimum horizontal distance from the stream. Base the distance from the stream upon requirements set by the agencies having jurisdiction over the area around the stream or at the stream crossing.
- (5) Contact agencies having jurisdiction over stream crossing areas to review all requirements and to discuss the impact of the design on their requirements. Obtain written response and approval of horizontal and vertical alignment from agencies having jurisdiction prior to issuance of the design.

b) For dry ditches and concrete channels:

- (1) Provide a minimum four (3) feet cover over the top of the pipe.
- (2) If the design requires less than three (3) feet of cover, submit the design along with calculations for special pipe and trench protection, see Part Two, Section 3 (Selection of Pipe Material) for approval.
- (3) If the crossing is located under a concrete channel measuring ten (10) foot or more from top of channel to top of channel, then install the water pipeline in a casing pipe, see Part One, Section 17 (Tunnels and Casing Pipes)

c) Stream (water crossings):

- (1) Provide a minimum cover at the stream invert of three (3) feet or 1.5 times the OD of the crossing pipeline (whichever is greater). If unable to provide this cover requirement, provide a design according to Part Two, Section 2 (Pipeline Sizes and Materials (Gravity Sewer) for special pipe and Part Three, Section 4 (Buoyancy of Pipelines) and Section 9 (Pipeline Stream Crossings).
- (2) If the stream (water crossings) is greater than fifteen (15) feet deep (top of high bank to top of pipe) provide the following:
  - (a) For DIP, restrain all joints a minimum of one hundred (100) feet from edge of bank;
  - (b) Align the crossing perpendicular to the stream to the extent practical.
- 4) Design of gravity sewer pipelines upstream of a wastewater pumping station. If a surcharge could occur in the gravity sewer pipeline upstream of the pumping station due to high wastewater level in the pumping station at the design flow, provide a plot of the HGL on the profile. Identify the location and elevation of wastewater overflow points, as well as frame and cover elevations and basement elevations, as a result of an inoperative wastewater pumping station.



- 5) Plot the HGL on profile for the following:
  - a) Gravity sewer pipelines, which may operate under surcharged conditions.
  - b) All gravity sewer pipelines 15-inch and larger diameter.
- 6) Check pipe flotation for PVC sewer pipelines within high ground water; see Part Three, Section 4 (Buoyancy of Pipelines).
- 7) When determining depths of sewer pipelines for improved lots, see Part Two, Section 27 (Sewer House Connections).
- 8) For pipeline clearances with other pipelines and utilities, see Part Three, Section 3 (Pipeline Crossings and Clearances).
- 9) For the design requirements for structures in profile, see Part Two, Section 11 (Design of Structures).

**b. Labeling Pipeline in Profile.**

- 1) Label all existing and proposed pipe sizes, manhole/structure numbers, location and type of all structures and appurtenances, and fittings on profile and provide pipeline stations and invert elevation as required in this section. Show the following on the profile: pipe slope, type of pipe and pipe strength, class, etc., if not noted in General Notes. For additional information, see Part Two, Section 5 (General Horizontal Alignment) and Section 11 (Design of Structures).
- 2) Provide class of DIP, PVC AWWA C900 and RCP due to changes required under Part Two, Section 2 (Pipeline Sizes and Materials (Gravity Sewer)) and Section 3 (Selection of Pipe Material). Show on profile the limits and class of pipe.

**c. Profile Grade Lines.**

- 1) Pipelines within or adjacent to a roadway.
  - a) Existing roadway show the following:
    - (1) Centerline of Existing paving from field surveys.
    - (2) Existing Ground over Centerline Pipeline, from field surveys. If the ground elevation differs by one (1) foot or more, show both the centerline of existing paving and the existing ground over centerline of pipeline.
    - (3) Existing Established Centerline Roadway Grade from approved street grade drawing.
    - (4) If the roadway does not have an established roadway grade, provide the following:
      - (a) Contact the agencies having jurisdiction over the existing roadway and submit for approval



- all necessary designs and drawings. Show the established roadway grade on profile, labeling it, Established Centerline Roadway Grade.
- (b) At the option of WSSC, show only the design of the roadway improvements on profile, labeling it, Possible Future Centerline Roadway or Possible Future Grade.
- b) New or proposed roadways show the following:
- (1) Centerline of Finished Roadway Grade.
  - (2) Finished Grade over Centerline Pipeline, if the grade elevation differs by one (1) foot or more show both the centerline of finished roadway grade and the finished grade over centerline of pipeline.
  - (3) Finished Grade is the proposed elevation over the pipeline during or after pipeline construction.
- 2) Outfall - across property, show the following.
- a) Existing Ground over Centerline Pipeline.
  - b) Finished Grade over Centerline Pipeline.
- 3) Pipeline parallel to existing or proposed streams, ditches, etc. and within 10 feet of the bank or slope, the Designer should show the bottom of the ditch, stream, etc. on the profile. The depth of the pipeline in profile should be such as to provide for future connections and/or extensions crossing the stream, ditches, etc. Provide preliminary design of future connections crossing the streams, ditches, etc.
- 4) Indicate grade/ground lines on the profile as follows:
- a) Centerline of existing roadway - solid line.
  - b) Established or possible future centerline of roadway - dashed line.
  - c) Existing ground or grade over centerline of pipeline - solid "freehand" line.
  - d) Proposed grade over centerline of pipeline - dashed "freehand" line.

**d. Length of Profile.**

- 1) Show grade or ground lines, entire length of the pipeline.
- 2) When connecting to existing mains or ending the pipeline, show an additional two hundred (200) feet of the following:
  - a) Existing and proposed grade or ground lines and the existing pipeline from the new pipeline or past the limits of the new pipeline when ending with a stopper.
- 3) Sufficient future extension of the pipeline design must be shown to assure proper depth of the alignment. The amount of additional length will be determined on a case by case basis.



**e. Pipeline Stationing.**

- 1) Measure the pipeline stations along centerline of the pipeline in the horizontal plane.
- 2) Pipeline within or adjacent to a roadway.
  - a) For horizontal stations on the baseline of the profile, show the centerline of the roadway with the location of the pipeline manholes, structures, etc., projected onto the centerline of the roadway. The horizontal distances between structures cannot be scaled accurately on the profiles where they are not entirely parallel to the centerline.
  - b) Distances noted on the drawings between manholes, structures, etc., on the pipeline profile are to be the actual distances measured horizontally along the pipeline, see Part Two, Section 15 (Pipe Slope and Manhole Distance).
- 3) Outfall - across property. Horizontal distances and stations on the profile represent the centerline distances and stationing along the pipeline.



## 9. Vertical Alignment - Pipe Slope.

### a. General.

- 1) Design grades to minimize excavation, while satisfying the minimum and maximum velocity, clearance, and depth requirements.
- 2) Consider the following maintenance concerns when determining pipe grades.
  - a) Very steep grades, low flat grades, deep drop connections at manholes, etc., may save initial costs, but the savings will likely be offset by the increased long term costs of maintaining the system.
  - b) For release of Hydrogen Sulfide (H<sub>2</sub>S) caused by changes in grade or by drop connections at manholes, see requirements in Part Two, Section 16 (Manhole Drop Connections) and Section 29 (Hydrogen Sulfide (H<sub>2</sub>S) Control).
  - c) Problems occur when silt and grease build up where the flow exits from a steep pipe grade and enters a pipe on a flat pipe grade. Balance the pipe slopes to provide a more constant grade.
- 3) Provide continually increasing sewer pipe sizes running downstream. When the slope of the sewer changes and a decreasing pipe size can handle the flow, at the sole discretion of WSSC, the sewer pipe size can be reduced by one pipe size.
- 4) See Part Two, Section 15 (Pipe Slope and Manhole Distance) for pipe slopes ten (10%) percent or greater.

### b. Minimum Pipe Slopes.

- 1) Minimum pipe slopes, see Table "11".

**TABLE "11"**  
Minimum Pipe Slopes

Pipe Sizes	Minimum Slope
4-inch and 6-inch SHCs	2.00%
8-inch Terminal Sewer Mains	1.00%
8-inch Sewer Mains	0.60%
10-inch Sewer Mains	0.46%
12-inch Sewer Mains	0.34%
15-inch Sewer Mains	0.24%
18-inch Sewer Mains	0.19%
21-inch Sewer Mains	0.14%
24-inch Sewer Mains	0.12%
30-inch Sewer Mains	0.10%
36-inch Sewer Mains	0.07%

- 2) Table "11" is based upon Manning's Formula,  $n = 0.013$  and a velocity of two and one-half (2.5)



fps for self cleaning velocities at half capacity flows.

- 3) For pipe sizes larger than 36-inch diameter, use the above requirements and submit hydraulic calculations in support of the sewer design.
- 4) Do not **increase** the diameter of the sewer pipeline to suit the minimum slope as shown on Table "11".
- 5) No exceptions to changing the minimum slopes.
- 6) Pipe sizes larger than 12-inch, submit the pipe slope design data calculations.
- 7) For additional requirements see Part Two, Section 2 (Pipe Size and Materials (Gravity Sewer)) and Appendix C (WSSC Design Criteria for Sewer Systems) for Hydraulic Design for Sewer Pipelines.
- 8) Slopes greater than those shown in Table 11 are desirable.

**c. Maximum Pipe Slopes.**

- 1) Submit a statement to WSSC, stating that all the pipeline velocities are under fifteen (15) fps.
- 2) When the pipeline velocity is fifteen (15) fps or greater, see design requirements for high velocities in pipelines under Part Two, Section 15 (Pipe Slope and Manhole Distance).

**d. Steep Pipe Slopes to Flatter Pipe Slopes.**

- 1) When steep pipe segments are followed by sections with flatter slopes, problems may occur. (Debris accumulating, surcharging and/or potential for hydrogen sulfide generation).
- 2) For sewers 12-inch and smaller and when incoming pipe slopes are over five (5.00%) percent and the outgoing slope is less than one half (1/2) the incoming slope, change the pipe slopes **so that the incoming upstream pipe has a slope less than twice the slope of the immediate downstream pipe.**

Example: If the incoming slope is set at 6% make the next downstream sewer segment **less than 3%.**

- 3) For sewers greater than 12-inches, submit hydraulic calculations **for steep pipe slopes to flatter pipe slopes.**



## 10. Tunnels or Casing Pipes.

### a. Requirements.

- 1) When crossing MSHA roadways, railroads, **Maryland Transit Administration (MTA) Rail Lines**, and county roadways in which the jurisdictional agency requires the pipeline to be in a tunnel or casing pipe, the following is required:
  - a) Tunnels or casing pipes are to be filled with **2000 psi concrete, grout or flowable fill**, see Standard Detail M/17.0.
  - b) **When the tunnels or casing pipes are constructed by open cut method, see Standard Detail M/17.6 for size of tunnel or casing pipes. Note on the drawings to fill with 2000 psi concrete, grout or flowable fill**
  - c) Design the sewer pipeline (class of carrier pipe) for the pipe depth, disregarding the tunnel or casing pipe, see Part Two, Section 3 (Selection of Pipe Material - Gravity Sewers).
  - d) Do not **design** PVC pipe in tunnels or casing pipes.
  - e) **No pipe joint deflections or fittings are to be installed in tunnels or casing pipes.**
  - f) Provide minimum of five (5) feet between end of tunnel and OD of a manhole.
  - g) For the diameter of the tunnel or casing pipe and additional details, see Standard Detail M/17.0.
  - h) For requirements on depth of tunnel or casing pipe and detailed design requirements, see Part Three, Section 25 (Tunnels) and Section 26 (Tunnel Design Criteria).
- 2) For Force Main requirements, see Part One, Section 17 (Tunnels or Casing Pipes).

### b. Size of the Pipeline in the Tunnel or Casing Pipe.

- 1) Consider increasing the size of the sewer carrier pipe to one **by** more pipe sizes, to allow for a future increase in flows since the pipe will be grouted into the tunnel. Consult with WSSC regarding increasing the pipe size.

### c. Installing Casing Pipes for Existing Sewer or Force Main Pipelines.

- 1) When required, install steel casing pipe.
  - a) **Casing pipe sizes for sewer mains, see requirement able in this section and for force mains see requirements under Part One, Section 17 (Tunnels or Casings).**
  - b) **Determine if alignment has joint deflection or fittings.**
    - (1) **If joint deflection or fittings exists, relocate existing pipeline to remove joint deflection or fittings.**
  - c) **Design the steel casing pipe to be divided in sections along the casing centerline.**



- d) Only a maximum of six (6) feet of existing sewer or force main pipeline may be excavated and exposed along the pipeline only at a time. This will provide support along the undisturbed pipeline.
- e) Design casing pipe as two (2) half sections of steel casing pipe, with welded sections.





## **11. Design of Structures.**

### **a. Manholes.**

- 1) Provide manholes in accordance with Standard Details S/1.0, S/1.1 and S/1.2.
- 2) Review Standard Details for pipe depth requirements, pipe slope limitations, and type of pipe material (RCP, PVC or DIP). For additional requirements, see the Part Two, Section 12 (Types of Manholes), Section 13 (Manhole Spacing), Section 14 (Pipe to Manhole Geometry), Section 15 (Pipe Slope and Manhole Distance), Section 16 (Manhole Drop Connections), Section 17 (Manhole Channel Design), Section 18 (Manhole Depth Design), and Section 19 (Manholes Built Over Existing Sewers).

### **b. Special Design Structures.**

- 1) Specially designed structures are required if the Standard Details are not adequate for the particular design. Provide details on the drawings, showing all necessary plan and section views, and label all materials, dimensions, etc.
- 2) Provide a minimum of six and one half (6-1/2) feet of head room inside the structure when maintenance of equipment or operation of flow control devices is required and a minimum of five (5) feet in all other locations. Base the design for the sewer pipeline on this minimum depth. For other requirements, see Part Three, Section 16 (Design of Pipeline Structures).

### **c. Design of Structures on Profiles.**

- 1) Verify that the invert of the pipeline is set at the proper depth with the details of the structure.
- 2) Provide existing and proposed ground elevations.

### **d. Horizontal Location of Manholes.**

- 1) Locate manholes at all sewer junctions and changes in alignment except in curved sections and according to the spacing requirements in Part Two, Section 13 (Manhole Spacing).
- 2) Locate manhole frames and covers out of sidewalks or parking areas unless approved by WSSC.
- 3) Manholes located within a storm management facility. Locate manholes out of the two (2) year design storm pool elevation. For additional information, see Part Two, Section 22 (Impact of Storm Water Facilities on Existing Sewers).
- 4) When the manhole frame and cover is designed near a sidewalk, curb, etc., indicate on the drawings by note, to rotate the top section (cone) to clear the sidewalk, curb, etc.

### **e. Vertical Location of Manholes.**

- 1) Locate manholes at all pipeline junctions, at all changes in grade and according to the spacing requirements in Part Two, Section 13 (Manhole Spacing).



**f. Diameter of Frames and Covers.**

- 1) Unless otherwise indicated, the required manhole openings are as shown in Table "12" and in accordance with Standard Details.

**TABLE "12"**

Diameter Requirements for Manhole Frames and Covers

Manhole Inside Diameter	Diameter of Manhole Frames and Covers
48-inch	24-inch
60-inch	30-inch
72-inch	36-inch
84-inch	36-inch
96-inch	36-inch
Larger Than 96-inch	36-inch
48-inch Shallow Type	30-inch

**g. Setting of Frames and Covers.**

- 1) Design the frames and covers as follows and provide WSSC with computations (tabulation sheet) supporting the frame and cover elevations.
- a) Within a proposed or future roadway with established road grades, provide the elevation of the top of the manhole frame and cover, see Sketch "L". When established roadway grade profile is used to calculate the elevation of the frame and cover, give the elevation to the hundredth of a foot. When established roadway grade or grading plan showing contour lines is used to calculate the elevation of the frame and cover, give the elevation to the tenth of a foot. If the manhole falls within a roadway indicate the roadway grade slope in percent (%) in the direction of the profile see Sketch "L".
  - b) Outside limits of grading design manhole or vault frame and cover to the existing ground elevation, see Sketch "M".
  - c) Existing areas or developments design manhole or vault frame and cover to existing ground, see Sketch "M".
  - d) Undeveloped areas, the manhole frame and cover are normally designed to one (1) foot above the existing ground elevation, see Sketch "M".
  - e) Areas of future grading over the pipeline.
    - (1) When the future grading will increase the soil cover over the pipeline by two (2) feet or more, set the frame and cover elevation to the initial grading, with the manhole and pipeline designed to handle the additional fill and provide the future elevation of the frame and cover on the drawings.
    - (2) When the future grading increases the cover over the pipeline by less than two (2) feet, set the frame and cover elevation to the future grade or as directed by WSSC.



- (3) When the future grading will decrease the cover over the pipeline, set the frame and cover elevation to the initial grading and provide the future elevation of the frame and cover on the drawings.

#### h. Labeling Manholes on the Drawings.

- 1) On plan and profile, label manholes as follows:

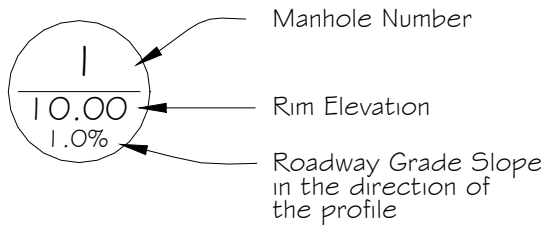

SKETCH "L"

Labeling Manholes or Vaults on Proposed or Finished Grades

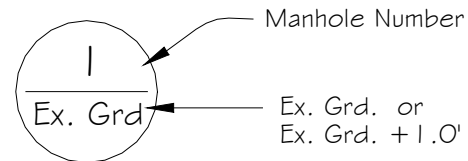

SKETCH "M"

Labeling Manholes or Vaults on Existing Grades

#### i. Infiltration - Sewerage Structures.

- 1) Infiltration Design. Base the design details on the Standard Details and Specifications whenever possible to prevent groundwater infiltration.
- 2) Design cast in place concrete structures on the following and Part Three, Section 16 (Design of Pipeline Structures).
  - a) Design structure, joints and penetrations to prevent infiltration.
  - b) Provide joints with waterstops.
  - c) Seal joint between wall and top slab with flexible gasket material in accordance with Specifications or with other materials if approved by WSSC.
  - d) Provide watertight manhole frame and covers for manway (access) openings.
  - e) Design the connections between pipe and wall to be either rigid or flexible. In either case, specify a bentonite collar in accordance with Standard Detail S/3.01.
    - (1) Provide flexible connectors in accordance with the Specifications; consult with manufacturers to verify availability of flexible connectors in the various sizes required.
    - (2) Rigid connections require a pipe joint within two (2) feet outside of the structure wall.



## 12. Types of Manholes.

### a. General.

- 1) Design all manholes as precast concrete, with the option given to the contractor to construct cast in place concrete manholes.
- 2) For design of manhole depths and diameter see Part Two, Section 18 (Manhole Depth Design).

### b. Types of Manholes.

#### 1) Precast concrete manholes.

- a) Minimum manhole diameter is 48-inch and maximum manhole diameter is 96-inch, see Standard Details S/1.0, S/1.1 and S/1.2.
- b) If a manhole larger than 96-inch diameter is required, verify if they are available from all WSSC approved manufacturers of precast concrete manholes and submit design details, calculations and specifications for approval. Show all details on the drawings.

#### 2) Brick manholes.

- a) Brick manholes are not permitted for new construction.
- b) When the design requires modifications to an existing brick manhole, see Part Two, Section 18 (Manhole Depth Design), to determine if the existing brick can be modified in place. If not, design the manhole to be replaced with a precast concrete manhole.
- c) Minimum manhole diameter is 48-inch and maximum diameter is 84-inch, see Standard Detail S/3.0.
- d) When connecting to an existing brick manhole, include the following in the design. Design only DIP or RCP pipelines between existing brick manholes and new manholes. Do not use PVC pipe to connect to existing brick manholes. Provide a note on the drawings stating the following: "Existing brick manhole. Grout pipe in the existing brick manhole with non-shrink grout and provide bentonite at the connection, see Standard Detail S/3.0".

- 3) Cast in place. When precast manhole requires a special design or size, it may be necessary to provide a cast in place structure, see requirements in Part Three, Section 16 (Design of Pipeline Structures).

### c. Labeling Manholes on the Drawings.

- 1) When connecting to an existing manhole, indicate if it is precast, brick or cast in place. The information for the type of existing manhole material can be taken from the "As-Built" drawings or if necessary, site visits to determine the type of manhole.
- 2) If a new manhole is larger than 48-inch diameter, provide the diameter of manhole on the sewer profile and/or in the General Notes.



### 13. Manhole Spacing.

#### a. Location.

- 1) Provide manholes at all breaks in the horizontal and vertical plane for 24-inch and smaller sewer mains.
- 2) Provide manholes on 27-inch and larger sewers at all breaks in the horizontal and vertical planes, except when the horizontal alignment is in a curve or when the use of bends has been approved, see Part Two, Section 4 (Fittings) and Section 6 (Curved Horizontal Alignment).
- 3) When the design of the sewer is near an existing/proposed water pipeline 16-inch and larger, which has a blowoff connection, locate the sewer manhole as close as possible to the blow-off connection to allow for the discharge of chlorinated water.

#### b. Maximum Spacing Between Manholes.

- 1) For maximum spacing between manholes, see Table "13".

**TABLE "13"**  
Maximum Manhole Spacing

Pipe Size	Maximum Manhole Spacing
8-inch to 24-inch	400 feet
27-inch to 42-inch	600 feet
48-inch and larger	600 feet, unless otherwise approved by WSSC

#### c. Minimum Spacing Between Manholes.

- 1) Outside diameter (OD) of adjacent manholes (including the bottom slabs) should have minimum of five (5) feet horizontal clearance.

**Example:**

8-inch sewer pipeline connecting to a four (4) foot diameter manhole, provide ten (10) feet horizontal distance between the centerline of manholes to achieve the 5 foot outside horizontal clearance.



## 14. Pipe to Manhole Geometry.

### a. General.

- 1) Design manholes with sufficient inside dimensions to perform inspection and cleaning operations, allow for proper channel construction without difficulty and minimize hydraulic losses through the manhole. Determine the appropriate size and shape of each manhole. For types and diameters of manholes, see Part Two, Section 12 (Types of Manholes).
- 2) Design the channel to conform to Standard Detail S/3.3 and provide adequate space within the manhole for removal of existing pipe, design the channel to suit the existing channel flow and **with** adequate width at the top of the bench within the manhole for worker safety and maintenance, see requirements in Part Two, Section 18 (Manhole Channel Design).

### b. Minimum Diameter Precast Manholes for Maximum Sewer Sizes.

- 1) Minimum inside diameter of new precast manholes for maximum sewer pipe size, see Table "14". See additional requirements under Part Two, Section 17 (Manhole Channel Design) for 12-inch and smaller sewer pipelines.

**TABLE "14"**

Minimum Diameter Precast Manholes for Maximum Sewer Sizes

Manhole Diameter	45° Deflection Maximum Size of Pipe <sup>A</sup>	90° Deflection Maximum Size of Pipe <sup>B</sup>
48-inch <sup>C</sup>	24-inch	18-inch
60-inch	36-inch	27-inch
72-inch	42-inch	30-inch
84-inch	48-inch	36-inch
96-inch	60-inch	42-inch

<sup>A</sup> Maximum pipe size for a given manhole diameter is based on straight through pipe alignment to forty five (45°) degree deflection through the manhole.

<sup>B</sup> Maximum pipe size for a given manhole diameter is based on forty five (45°) to ninety (90°) degree deflection through the manhole, without any other pipe connection to the manhole.

<sup>C</sup> Maximum depth of 48-inch diameter manhole is twenty (20) feet. Over twenty (20) feet requires a five (5) foot diameter manhole, see Part Two, Section 19 (Manhole Depth Design).

### c. Minimum Diameter of Existing Brick Manholes for Maximum Sewer Sizes.

- 1) Design brick manholes, only if an existing brick manhole has to be modified, see Part Two, Section 12 (Types of Manholes). Minimum inside diameter of existing brick manholes for the maximum sewer pipe size, see Table "15".

**TABLE "15"**

Minimum Diameter Existing Brick Manholes for Maximum Sewer Sizes

Manhole Diameter	No Deflection – Straight Run <sup>D</sup>
48-inch	Up to 24-inch
60-inch	27-inch to 36-inch
72-inch	42-inch to 48-inch
84-inch	54-inch to 60-inch

<sup>D</sup> When the sewer requires deflection at the manhole, determine the deflection angle and the required manhole diameter from Table "14". Provide a new precast manhole if size must be increased.



**d. Determining Manhole Diameter.**

- 1) New precast manholes. To determine the inside diameter and/or deflection angle, see Table "14", or provide calculations using the following:
  - (a) Determine the type of material to be used for the sewer pipeline, (PVC, RCP [use ASTM C76, Wall C] or DIP) and determine maximum pipe size for diameter of the manhole using the following formula for pipes flowing straight through a manhole:
 

Maximum pipe outside diameter =  $0.707 \times \text{ID of the manhole}$ .
  - (b) Check the distance between pipe openings; see Sketch "N". Provide a minimum of 9 inches or 1/2 the pipe OD, whichever is greater, between the manhole pipe hole openings of both pipes. When the adjacent pipes are different sizes, use 1/2 the pipe OD of the smaller pipe or 9 inches, whichever is greater.
  - (c) When the minimum clearances between pipe openings cannot be met, see Offset Manholes, in this section.

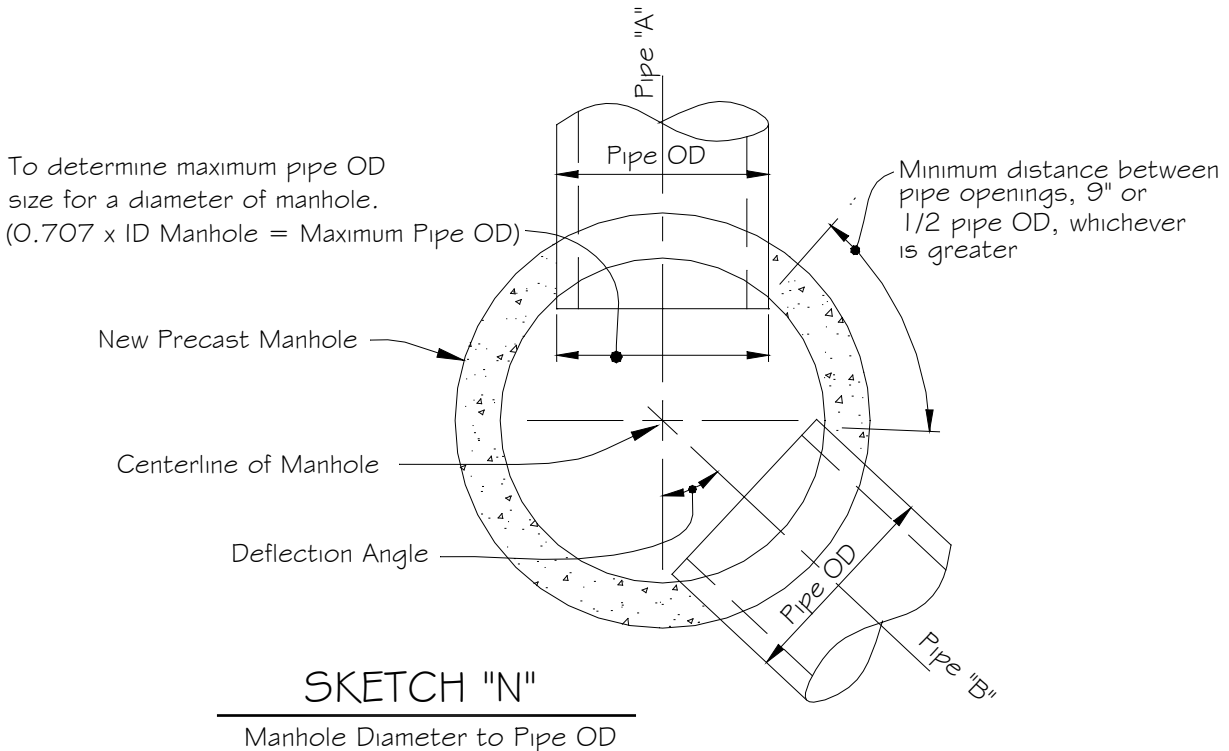
**Example:**

For a 48-inch ID manhole:

Determine the maximum OD of the sewer connections at a 48-inch ID manhole.

$$0.707 \times 48" = 33.94"$$

Determine the size of pipe ID; see the chart in ASTM C76 for Wall C.

$$27\text{-inch RCP (OD)} = 35" \text{ and } 24\text{-inch RCP (OD)} = 31.5",$$

Therefore, for a 48-inch ID manhole

Maximum size of sewer pipeline using RCP is 24-inch diameter.

Next, verify the angles between the sewer pipelines, see Tables "14" and "15" or Sketch "N".



2) Existing precast manholes.

- a) If the existing manhole has an existing connection (stub), match the existing pipe material or remove the connection if the pipe material is not one of the approved pipe materials in accordance with Specifications.
- b) If the manhole has no existing connections, the manhole will require a field connection to be installed. This connection is called "Field Gasket Connector", see Specifications.
  - (1) Determine the maximum pipe size allowed at the existing manhole. The field gasket connector requires an opening equal to the OD of the sewer pipe plus 7" (or 3-1/2" on each side of the pipe OD).
  - (2) Determine the minimum clearances between two pipe openings at the manhole, one being existing and the other using a field gasket connector. The field gasket opening requirement must be added to the new pipe diameter for this calculation. See Sketch "O".
- c) When the minimum clearances between pipe openings cannot be met, see Offset Manholes in this section.

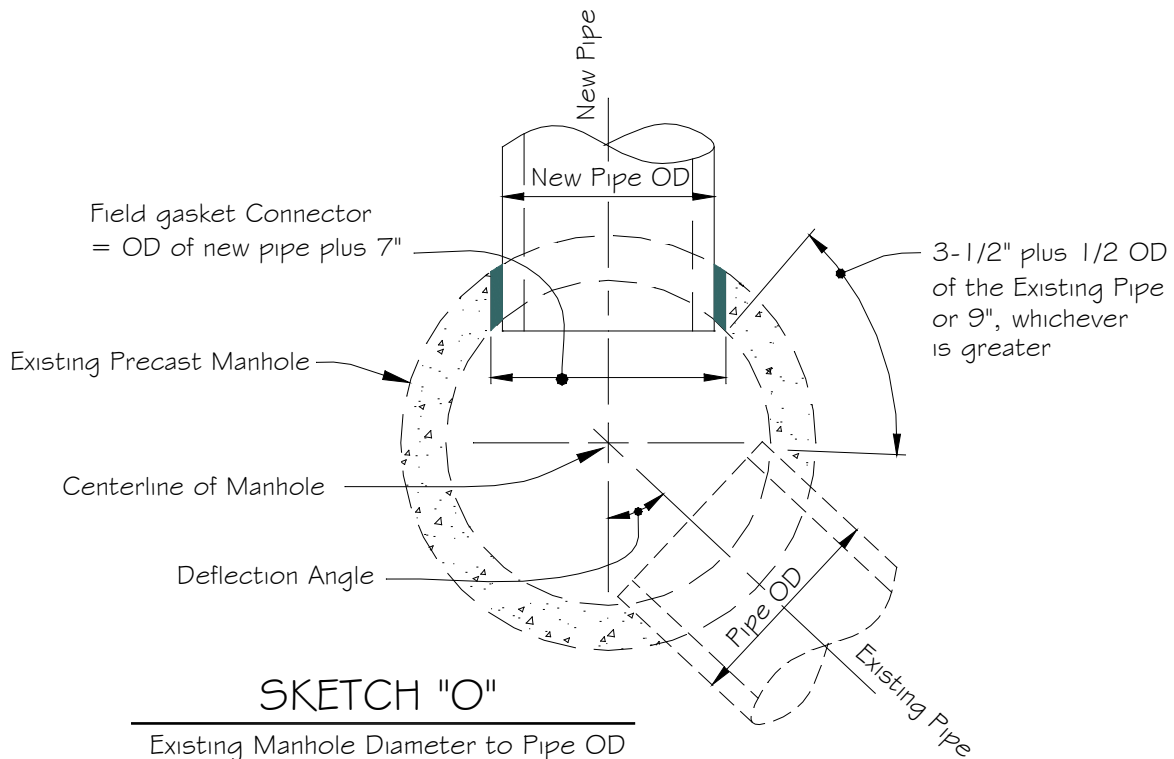
3) Existing brick manholes.

- a) If the existing manhole has an existing connection (stub), match the existing pipe material or remove the connection if the pipe material is not one of the approved pipe materials in accordance with Specifications.





- b) If the manhole has no connections, the manhole will require a connection to be constructed in accordance with Standard Detail S/3.0a and Specifications. New sewer pipe connecting to the existing brick manhole can only be DIP or RCP. Provide nine (9") inches minimum clearance between sewer pipe OD's at the inside of the manhole wall following Sketch "N".
- c) When the minimum clearances between pipe openings cannot be met, see Offset Manholes, in this section.

**e. Offset Manholes.**

- 1) When the clearance between the pipe openings is not in accordance with Sketch "N" and "O" or if the sewer pipe leaving the manhole has a problem with clearances, provide a design for the sewer to be offset or askew at the manhole. The design will require details, dimensions, etc., to be shown on the drawings, see Sketch "P".

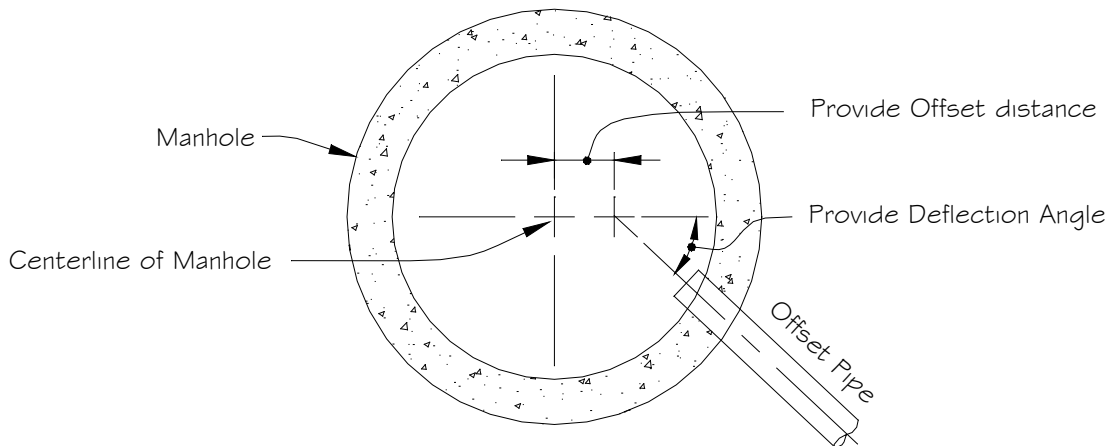

**SKETCH "P"**

Offset Manhole

**f. Mechanical Flow Control Devices in Manholes.**

- 1) For special manholes that require mechanical flow control devices (slide gates, weirs, etc.), provide detailed drawings showing locations, manufacturer's recommendation, required clearances, etc., with sufficient inside dimensions for installation and removal of these devices.
- 2) These devices will require the manhole or vault to have an opening large enough for their removal. In some cases, additional access equipment hatches may be required.

**g. Non-Circular Manholes.**

- 1) If the design requires a manhole to be non-circular, provide all necessary details required to construct this type of manhole.



**h. Special Pipe Openings in Manholes.**

## 1) Manhole connections for steep pipe grades.

- a) Pipe connections to precast concrete manholes are typically installed with a flexible type gasket per the Specifications. When the pipe slope is greater than ten (10%) percent for sewer pipeline materials other than PVC (AWWA C900) pipe, the flexible gasket cannot be used and the pipe opening at the manhole wall requires the diameter of the opening to be larger in diameter or oblong, see Standard Detail S/3.03. Provide all necessary details required, see requirements below and Sketch "R". For PVC AWWA C900 pipe requirements on pipe slopes ten (10%) percent or greater, see Part Two, Section 16 (Pipe Slope and Manhole Distance).

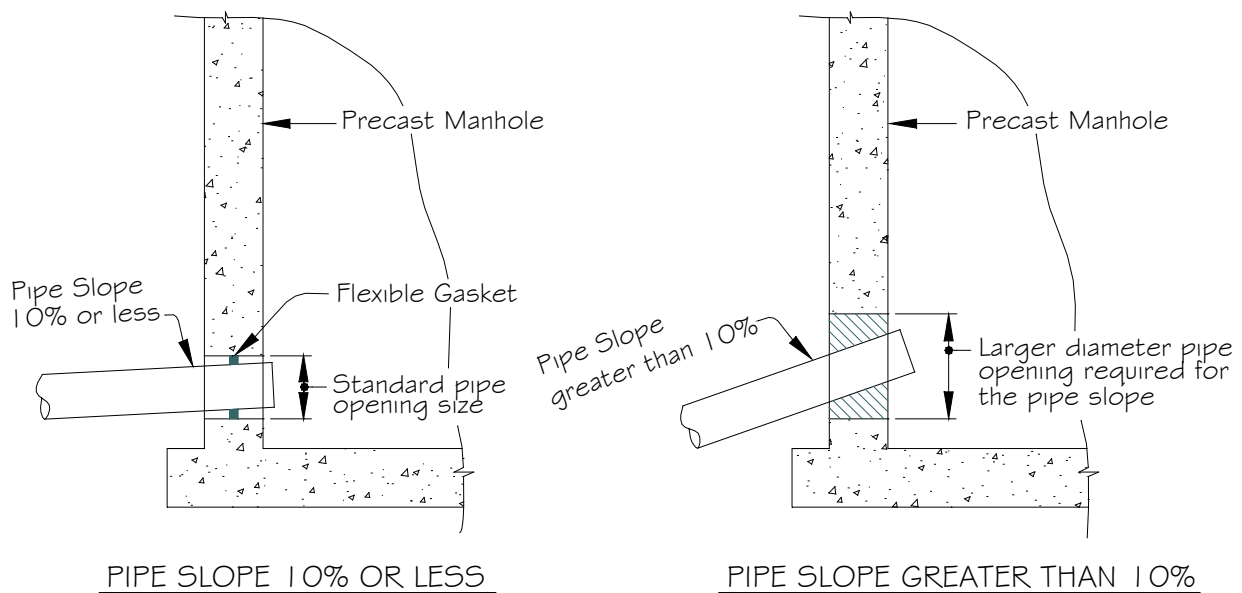
**SKETCH "R"**

Pipe Manhole Connection for Steep Grades

b) Sewers 12-inch and smaller.

- (1) Pipe slopes ten (10%) percent or greater and sewers 12-inch or smaller, see Standard Detail S/3.03 and use PVC (AWWA C-900) pipe only, see Part Two, Section 15 (Pipe Slope and Manhole Distance).
  - (2) Pipe slope greater than sixty (60%) percent. Indicate the size of the pipe opening on the drawings and coordinate with the manhole manufacturer to assure the proposed opening dimensions are compatible with the precaster's capabilities.
  - (3) Review the design of the pipe slope, to determine if the slope could be changed so that the pipe slope is under ten (10%) percent, see Part Two, Section 15 (Pipe Slope and Manhole Distance) and Sketch "T".
- c) Sewers greater than 12-inch diameter. Indicate the size of the pipe opening on the drawings,



specify DIP, PVC AWWA C-900 or RCP and coordinate with the manhole manufacturer to assure the proposed opening dimensions are compatible with the precaster's capabilities.



## 15. Pipe Slope and Manhole Distance.

### a. Design.

- 1) Indicate the invert elevation on profile for each pipe entering and leaving the manhole at the inside manhole wall.
- 2) Pipe slope and distance for sewers smaller than 48-inch diameter.
  - a) To determine the pipe distance for sewers smaller than 48-inch, subtract one-half (1/2) the inside manhole dimension for both manholes from the total distance between the centerline of both manholes. The distance between the manholes that is shown on the profile is the total distance between the centerlines of the manholes.

#### **Example:**

If both manholes are 48-inch diameter, the total distance between both manholes (centerline to centerline) is 304 feet, and the distance between the centerline of the manhole to the inside wall of the manhole is two (2) feet.

Since both manholes are the same diameter, subtract four (4) feet from the total distance.

$304 - 4 = 300$ , the pipe distance between manholes will be 300 feet but a distance of 304 feet should be shown on the profile.

- b) To determine the pipe slope, subtract the two manhole inverts and divide the difference by the pipe distance and multiply by one hundred (100) to obtain the percent grade of the pipe.

#### **Example:**

If the manhole invert elevations are 101.00 for one manhole and 99.00 for the other, then the difference between the two manhole inverts will be 2.0 feet.

Take the invert difference (2.0 feet) and divide it by the pipe distance (300 feet). The pipe slope will be 0.0067 feet per hundred feet or 0.67%. Show the pipe slope on the profile.

- 3) Pipe slope and distance for sewer pipelines 48-inch and larger diameter.

- a) To determine the pipe distance for 48-inch and larger sewers in circular manholes, determine the amount of pipe that is extended into the inside diameter of the manhole (d), See Sketch "S".

First determine (a), which is one half (1/2) the pipe OD and (c), which is one half (1/2) the manhole inside diameter. Solve for (b), using this formula.  $b = (c^2 - a^2)^{1/2}$

Then, determine the amount of pipe that is extended into the inside of the manhole.

Solve for (d), using this formula  $d = c - b$

After determining (b) for each manhole (each end of the sewer run), then determine the pipe distance between the two (2) manholes. To determine the pipe distance, add the two (b) dimensions and subtract it from the total distance between the centerline of the two (2) manholes.



**Example:**

If both manholes are seven (7) foot diameter, the pipe is 48-inch RCP, wall C and the total distance between both centerline of manholes is 600 feet.

$$c = 3.5 \text{ feet (1/2 of 84-inch diameter manhole)}$$

$$a = 2.48 \text{ feet (1/2 of OD of 48-inch RCP, wall C pipe, which has an OD of 59.5")}$$

Solve for b.

$$b = (c^2 - a^2)^{1/2}$$

$$= (3.5^2 - 2.48^2)^{1/2}$$

$$= (12.25 - 6.15)^{1/2}$$

$$= (6.10)^{1/2}$$

$$b = 2.47 \text{ feet}$$

Then, determine the pipe distance, since both manholes are 84-inch diameter, multiply 2.47 (b) by 2 and subtract it from the total distance between the two manholes.

$$2.47 \times 2 = 4.94 \quad 600 - 4.94 = 595.06 \quad \text{The pipe distance will be 595.06 feet.}$$

- b) To determine the pipe slope, subtract the two manhole inverts and divide the difference by the pipe distance and multiply by one hundred (100) to obtain the percent grade of the pipe.

**Example:**

If the manhole invert elevations are 200.00 for one manhole and 199.00 for the other, than the difference between the two manhole inverts will be 1.0 foot.

Take the invert difference (1.0 foot) and divide it by the pipe distance (595.06 feet). The pipe slope will be 0.0017 feet per hundred feet or 0.17%. Show this pipe slope on the profile.

- c) For non-circular manholes, determine the pipe distance from the special details for the manhole, see Part Two, Section 14 (Pipe to Manhole Geometry), non-circular manholes.

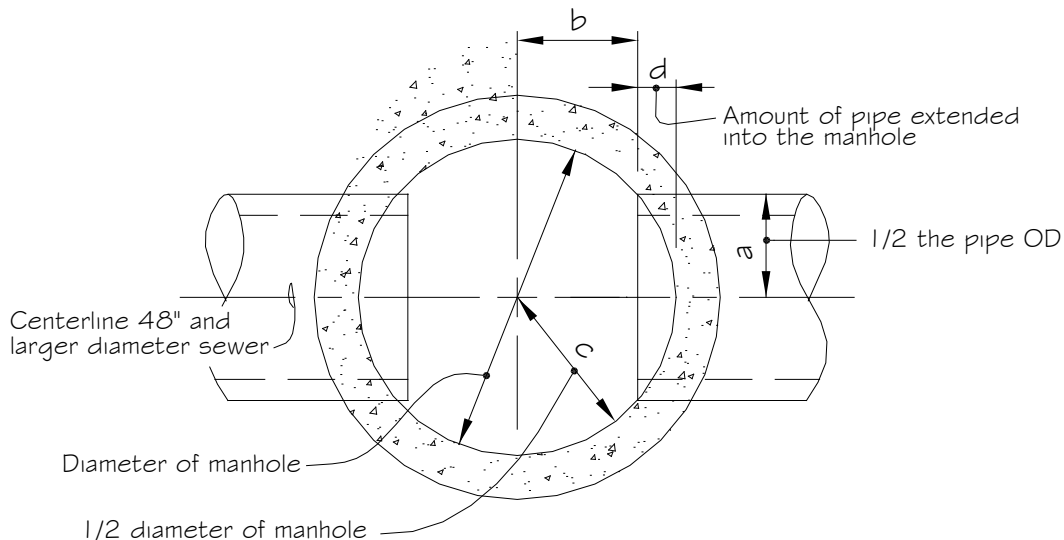
**SKETCH "S"**

Determining Pipe Length Between Manholes  
For Sewer Pipelines 48" and Larger



- 4) Verify that the pipe distances and pipe size shown on the plan drawings are the same as the profile drawings.

**b. High Velocities in Pipelines.**

- 1) When pipe grades produce velocities approaching fifteen (15) fps (feet per second) or greater at full capacity flow, provide a design according to one of the following with all flows, designs and details to account for high sewer velocities.
  - a) Review the pipe slope and determine if the velocity can be reduced by changing the vertical alignment slope by adjusting manhole distances, invert elevations, etc., or design the vertical alignment with a drop manhole connection, see requirements in Part Two, Section 17 (Manhole Drop Connections).
  - b) If the vertical alignment cannot be reduced, provide DIP or AWWA C900 PVC pipe for 12-inch and smaller sewer pipelines and DIP or PVC AWWA C905 for sewers larger than 12-inch, within the limits of high velocities, see design requirements in Part Two, Section 3 (Selection of Pipe Material).
- 2) In any case, orient manhole channel and other influent sewers/sewer house connections such that incoming flow from steep sewer pipelines is not directed into other incoming sewer/sewer house connections.

**c. Pipe Slope 10% to 35%.**

- 1) Review the pipe slope and determine if the slope can be reduced to under ten (10%) percent. This can be done by providing more distance between the manholes, providing more of a channel drop across the inside of the manhole so that the pipe slope can be reduced to under ten (10%) percent, see Sketch "T" and Part Two, Section 16 (Manhole Channel Design) or design a manhole drop connection at the manhole, see Part Two, Section 16 (Manhole Drop Connections).
- 2) If the slope cannot be reduced, specify **DIP or** AWWA C900 PVC pipe, see the Specifications for 12-inch and smaller sewer pipelines. Indicate the limits in the General Notes and on the profile drawing, to use only **DIP or** AWWA C900 PVC. For sewers larger than 12-inch, specify DIP or PVC AWWA C905. See design requirements in Part Two, Section 3 (Selection of Pipe Material). See Special Pipe Openings in Manholes under Part Two, Section 14 (Pipe to Manhole Geometry) for additional information. Also, see design requirements under Part Three, Section 14 (Anchoring Pipes on Steep Slopes).
- 3) In any case, orient manhole channel and other influent sewers/sewer house connections such that incoming flow from steep sewer pipelines is not directed into other incoming sewer/sewer house connections.



**d. Pipe Slope Greater Than 35%.**

- 1) When the pipe slope is greater than thirty-five (35%) percent, **DIP** or AWWA C900 PVC pipe.
  - a) For 12-inch and smaller sewer pipelines, used if Standard Detail S/3.03 is specified and a note is added indicating to see Specifications for exterior pipe wall at manhole wall. Specify and indicate the limits in the General Notes and on the profile drawing to use only **DIP** or AWWA C900.
  - b) For larger than 12-inches, provide a special design following Standard Detail S/3.03.
  - c) In all cases, a note is added indicating to see Specifications for exterior pipe wall at manhole wall. Specify and indicate the limits in the General Notes and on the profile drawing to use only **DIP** or AWWA C900 PVC pipe.
- 2) See Special Pipe Openings in Manholes under Part Two, Section 14 (Pipe to Manhole Geometry) for additional information. Also, see design requirements under Part Three, Section 14 (Anchoring Pipes on Steep Slopes).
- 3) In any case, orient manhole channel and other influent sewers/sewer house connections such that incoming flow from steep sewer pipelines is not directed into other incoming sewer/sewer house connections.

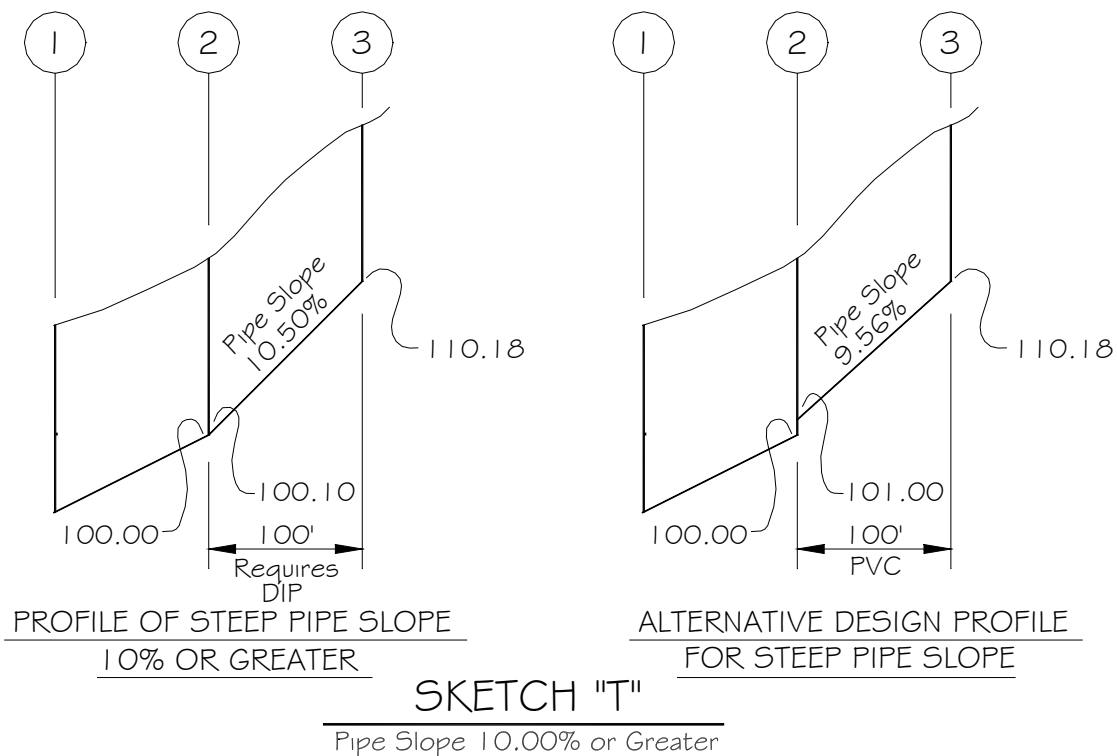

## 16. Manhole Drop Connections.

### a. General.

- 1) Manhole drop connections are to be in accordance with Standard Details S/3.1 and S/3.1a for 8-inch through 12-inch diameter sewers mains; S/3.1b and S/3.1c may also be used only for 8-inch diameter sewer mains. All other sizes of drop connections require special design. Larger size sewer pipelines are not usually specified because the fittings often exceed the space for their installation and/or the larger sizes of fittings may not be available.
- 2) **Do not design manhole drop connection to existing brick manholes.**
- 3) Do not design drop connections for future connections.
- 4) Label the manhole drop connections in plan and profile, and design the drop connection with the same pipe material as the incoming (influent) sewer. The Standard Details for drop manholes are just a schematic of the piping arrangement and do not represent specific fitting locations.
- 5) If a drop connection is to be designed for an existing pipeline, verify and determine the existing pipe material. If the drop connection cannot be constructed with the same material as the existing pipeline, use another alignment, or provide two (2) manholes; one over the existing pipeline and the other near by to have a transition between the different pipe materials.

### b. Design Requirements.

- 1) Determine the drop connection requirements using the following guidelines:
  - a) Standard Detail S/3.1, Type A drop manhole connections for 8-inch through 12-inch diameter sewer pipelines only. Maximum drop allowed at the manhole is 3'-9" and the minimum drop allowed is 2'-2".
  - b) Standard Detail S/3.1a, Type B drop manhole connections for 8-inch through 12-inch diameter sewer pipelines only and the minimum drop allowed at the manhole is 3'-9" and the maximum drop allowed is based on the following pipe slopes of the influent pipe entering the drop connection:
    - (1) Pipe slopes of five (5%) percent or less, the maximum drop allowed is twelve (12) feet.
    - (2) Pipe slopes of greater than five (5%) percent to fifteen (15%) percent, the maximum drop allowed is seven (7) feet.
    - (3) Pipe slopes of greater than fifteen (15%) percent to twenty (20%) percent, the maximum drop allowed is five (5) feet.
  - c) Standard Detail S/3.1b, Type B inside drop manhole for 8-inch PVC sewer pipelines connecting to precast concrete manholes. Only one inside drop can be constructed in the manhole, unless otherwise indicated on the drawings.
    - (1) Maximum pipe slope of the influent pipe is five (5%) percent.





- (2) Verify the following before specifying an inside drop manhole connection for an existing manhole:
    - (a) Existing manhole is precast concrete.
    - (b) Adequate room for personnel to work inside the manhole.
    - (c) The inside drop connection piping is not within the area that is defined by the projection of the manhole entrance vertically down to the manhole bottom. If necessary, relocate the existing frame and cover, existing precast cone section and existing manhole steps to allow unobstructed entry and exit.
  - (3) This detail can be used for existing brick type manhole; the Designer must submit special design for approval.
- d) Standard Detail S/3.1c, Type B inside drop manhole for 8-inch PVC sewer pipelines connecting to precast concrete manholes. Only one inside drop can be constructed in the manhole.
- (1) Maximum pipe slope of the influent pipe is less than ten (10%) percent.
  - (2) Verify the following before specifying an inside drop manhole connection for an existing manhole:
    - (a) Existing manhole is precast concrete.
    - (b) Adequate room for personnel to work inside the manhole.
    - (c) The inside drop connection piping is not within the area that is defined by the projection of the manhole entrance vertically down to the manhole bottom. If necessary, relocate the existing frame and cover, existing precast cone section and existing manhole steps to allow unobstructed entry and exit.
  - (3) This detail can be used for existing brick type manhole; the Designer must submit special design for approval.

**c. Design Considerations.**

- 1) When designing the vertical sewer alignment, review the profile to determine if drop manhole connections should be included. The following should be considered:
  - a) The cost of the drop manhole connection versus the cost of having the pipeline deeper, which increases the amount of excavation.
    - (1) Distance between manholes should be sufficient to make the manhole drop connection cost effective.
    - (2) Maintaining the pipeline should be considered in determining cost differences between designing drop connections at manholes or lowering the pipeline. Items that should be considered are: maintenance cost for cleaning the drop, repairing the drop when the manhole



- settles, repairing the eroded channels, release of Hydrogen Sulfide ( $H_2S$ ), etc.
- b) When other utilities cross a sewer near a manhole, adding a drop connection to the sewer vertical alignment may provide needed clearances for the utility crossing the sewer alignment.
  - c) Hydrogen Sulfide ( $H_2S$ ). The use of drop manholes is discouraged when it is found that Hydrogen Sulfide ( $H_2S$ ) is already present or is predicted to be likely in the wastewater. This is especially true downstream from a pump station or pressure sewer/force main discharge. These situations may result in the release of  $H_2S$ , which could likely corrode concrete manholes, concrete pipe, concrete lined pipe, or ferrous pipe materials. If drop manholes are required in these situations, evaluate the need for special provisions required to protect the pipe and associated structures. See Part Two, Section 28 (Hydrogen Sulfide Control) for additional requirements.

**d. Special Designs.**

- 1) Special design for drop manholes is usually required because the depth, pipe slope or pipe size of the incoming pipelines exceeds the requirements shown on the Standard Details S/3.1, S/3.1a, S/3.1b or S/3.1c. Consider the need for each drop on a case by case basis.
- 2) Show all necessary details on the drawings for all non-standard designs and modify the Standard Details to suit the special design for drop connections and indicate the required changes to the Standard Details on the drawings, see Part Three, Section 6 (Modifications to Specifications and Standard Details).
- 3) Examples for special designs for manhole drop connections.
  - a) When the incoming pipeline to the manhole drop connection has a pipe slope greater than twenty (20%) percent or the drop of the vertical pipe is greater than the allowable for Standard Detail S/3.1a, Type B drop connections, a special design, to be shown on the Drawings, could be made by changing the bend under the wye fitting from 1/8 bend to 1/16 bend.
  - b) Connecting to existing brick manholes.
  - c) Two (2) inside drop connections.



## 17. Manhole Channel Design.

### a. General.

- 1) When referencing the pipe invert elevations on the profile, provide the inverts of all pipes entering and exiting the manhole.
- 2) Pipes entering the manhole (in) can be at the same invert elevation if more than one pipeline is coming in the manhole and the pipelines are the same diameter. If the pipelines are not the same diameter, see Channel Slope, in this section.
- 3) Design the pipe exiting the manhole (out) at a lower invert elevation, see Channel Slope, in this section.
- 4) Channels for specially designed manholes and structures. When a manhole or structure is not in accordance with the Standard Details, provide all necessary dimensions, radius, etc., on the drawings to construct the manhole. Design the channel to conform to Standard Detail S/3.3.

### b. Channel Slope.

- 1) Design the drop or channel slope across the pipe inverts as follows:
  - a) Minimum drop between pipe inverts on mainline flow (in and out), same size diameter, design as follows and see requirements under angles between pipe entering manholes, in this section.
    - (1) For sewer pipelines 12-inch and smaller diameter, provide minimum drop of 0.10 foot.
    - (2) For sewer pipelines larger than 12-inch and smaller than 36-inch diameter, provide minimum drop of 0.10 foot or determine hydraulic loss to determine minimum drop across the pipe inverts.
    - (3) For sewer pipelines 36-inch and larger diameter, the drop across the pipe invert may have to be less than the 0.10 foot minimum. Determine hydraulic loss through the manhole and if greater than the minimum drop, provide drop equal to or greater than the hydraulic loss.
  - b) Maximum drop between pipe inverts entering and leaving the manhole, same size diameter, design as follows:
    - (1) For sewers pipelines 12-inch and smaller, the maximum drop is one (1) foot without providing a drop connection.
    - (2) For sewer pipelines larger than 12-inch, determine the hydraulic loss through the manhole and provide drop equal to or greater than the hydraulic loss. If design requires larger drop than calculated, a drop connection may be required.
  - c) Angles between pipes entering manholes.
    - (1) Consider the hydraulic losses created by sharp angles of pipes entering and leaving the manholes.



- (a) Provide an angle of ninety (90°) degrees or greater between the pipes entering and leaving the manhole.
- (b) For 12-inch and smaller sewer pipelines, when the angle of the pipes entering and leaving the manhole is between ninety (90°) degrees to one hundred twelve and one half (112.5°) degrees, see Table 16 and Sketch "U" for minimum drop.

**TABLE "16"**

Angles Between Pipes 12-inch and Smaller Entering Manholes and Minimum Drop Across Channel Inverts

Angle, see Sketch "U"	Angle Between Pipes Entering Manhole	Minimum Drop Across Channel Inverts		Minimum Drop Across Channel Inverts with Increased Radius of Channel/Diameter of Manhole
"A"	90° to 112.5°	0.24 feet	Or	0.16 feet and Increase channel radius to 3.0 feet and 6'-0" diameter manhole
"B"	112.5° to 135°	0.16 feet	Or	Increase channel radius to 3.0 feet and 6'-0" diameter manhole.

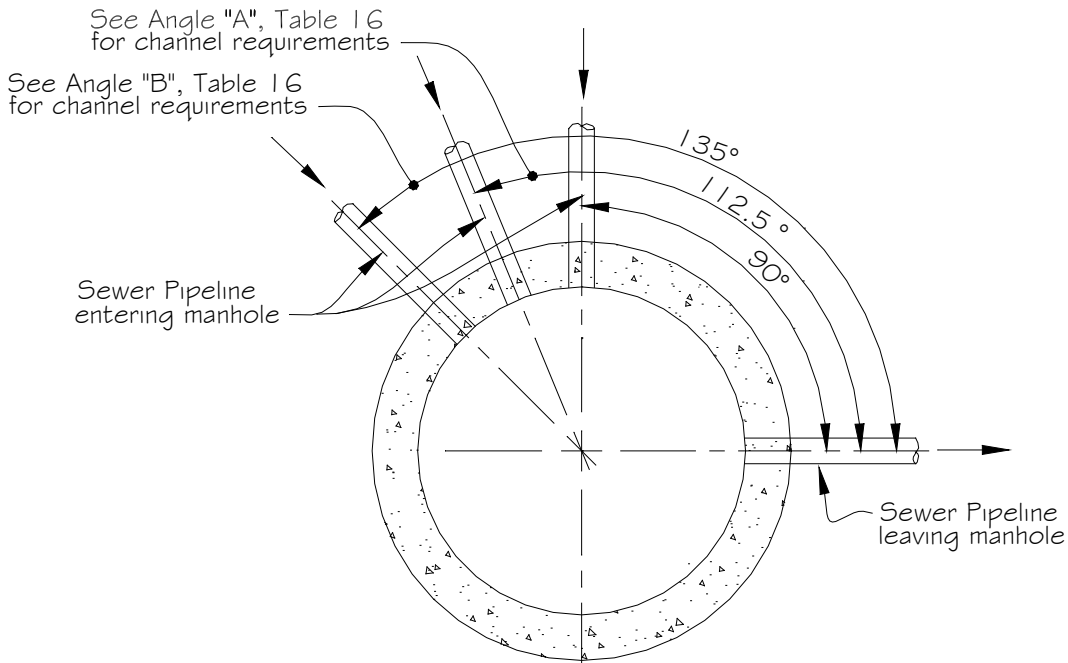

**SKETCH "U"**

Angles Between Pipes 12" and Smaller Entering Manholes

- d) Different pipe diameter entering and exiting the manhole, design invert elevations as follows:
  - (1) For sewer pipelines 12-inch and smaller, design the pipe invert elevations matching either the



5/6 flow depth of the different pipe diameters or the pipe crowns of the inlet and outlet pipes.

- (a) Matching the 5/6 flow depth may result in the crown of the larger pipe being slightly higher than the crown of the smaller pipe. In this case, adjust the larger pipe so that its crown matches that of the smaller pipe.
- (b) The invert of the outlet pipe shall be lower than the invert of the inlet pipe.

**Example A:**

6-inch SHC is entering the manhole at an invert elevation of 100.00 and an 8-inch Sewer Pipeline is exiting the manhole. First, determine the 5/6 flow of each pipe.

5/6 of 6" SHC = 0.42'      5/6 of 8" S = 0.56'      Then subtract 5/6 flows (0.42 from 0.56).

The difference in flows or inverts would be 0.14', which will make the invert of the 8" sewer leaving the manhole at an elevation of 99.86.

In this case, the inside top of the 6-inch SHC entering the manhole will be at an elevation of 100.50 and the inside top of 8-inch Sewer Pipeline exiting the manhole will be at an elevation of 100.53. In this case match the crowns elevations of the 6-inch SHC entering the manhole and the 8-inch Sewer Pipeline is exiting the manhole.

Matching crowns the difference in inverts will be 0.17', which will make the invert of the 8" sewer leaving the manhole at an elevation of 99.83, see Sketch "V".

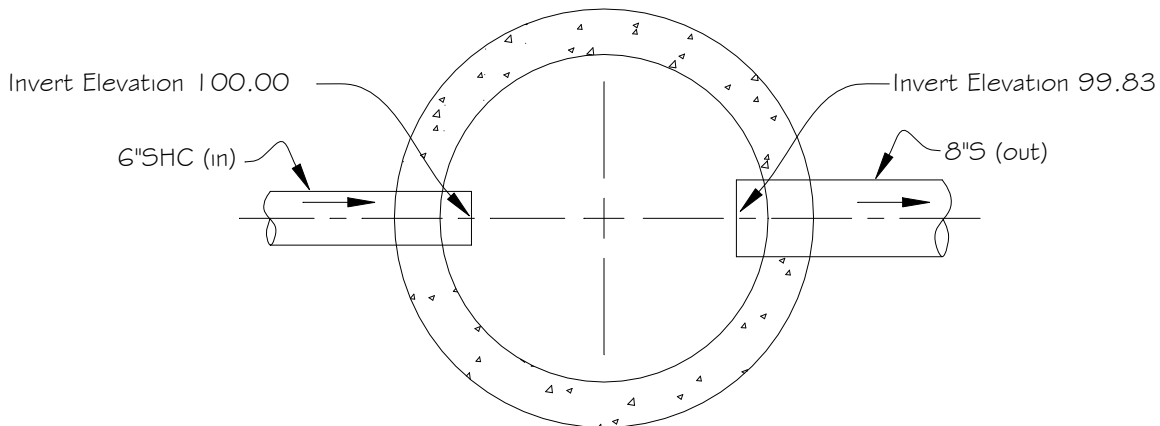

**SKETCH "V"**

Manhole Channel Design  
Matching Crown Elevations

- (2) Exception to matching the 5/6 flow depths or matching the crowns.

- (a) When one of the incoming pipelines is opposite (135° to 180° as shown on Sketch "W") the



other incoming (in) pipeline, see Sketch "W". In this condition, the invert of the smaller incoming pipeline must be set at a higher elevation than the invert of the larger pipe to avoid flow from the large pipe from entering the smaller pipe. This is accomplished by either: matching the crowns of the two pipes, then raising the invert of the smaller pipe by 0.20 feet, or matching the 5/6 flow levels, then raising the invert of the smaller pipe by 0.20 feet. The method resulting in the higher invert elevation for the smaller pipe is to be used.

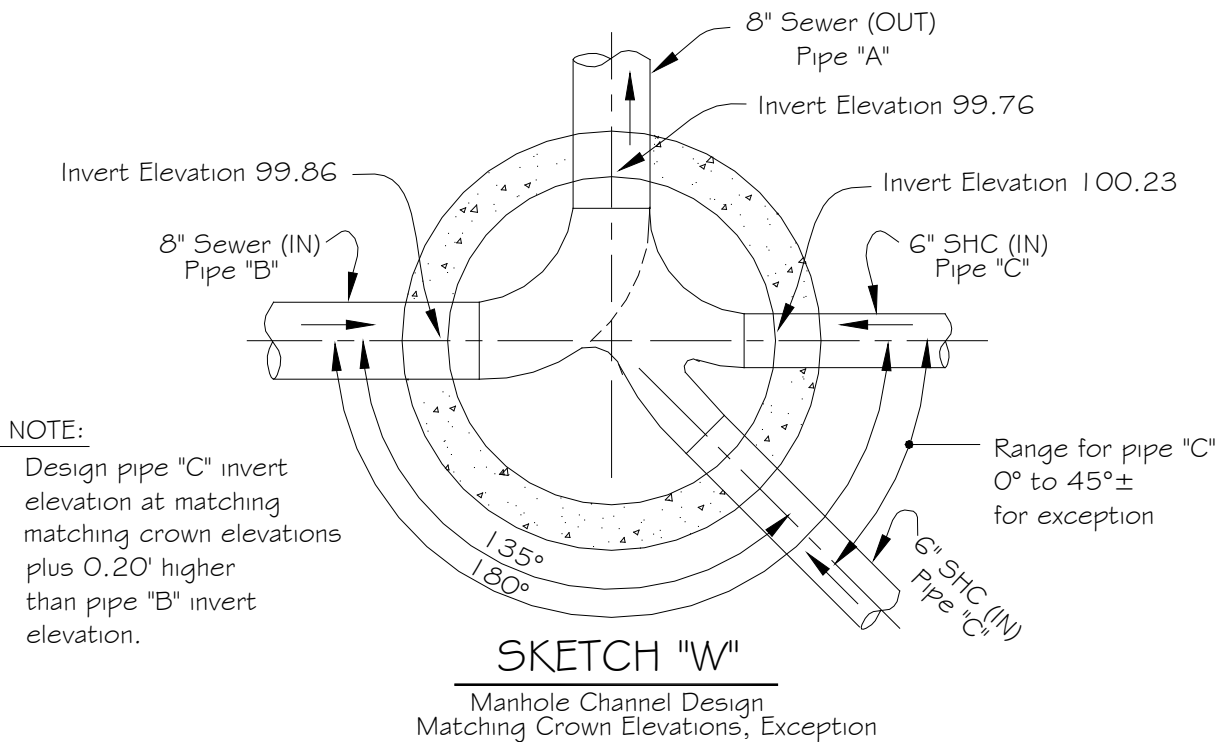

- (3) For sewer pipelines larger than 12-inch diameter and up to 27-inch diameter, design the pipe invert elevations by matching the crowns of the different diameter pipes. Determine hydraulic losses to verify the design.
- (4) For sewer pipelines larger than 27-inch, design the pipe invert elevations by matching the crowns of the different diameter pipes. For sewer pipelines larger than 27-inch diameter, with 12-inch and smaller laterals entering the manhole, design the laterals by matching the invert to or above the crown of the larger pipe to prevent flow from the larger pipe entering the smaller pipe. Determine hydraulic losses to verify the design.
- e) When the drop across the inverts (in and out) is greater than one (1) foot, adjust the inverts to suit the maximum one (1) foot drop or design the manhole with a drop manhole connection, see requirements under Part Two, Section 16 (Manhole Drop Connections).
- f) Evaluate drops across pipe inverts larger than 0.1 foot for hydrogen sulfide generation, see Part Two, Section 28 (Hydrogen Sulfide (H<sub>2</sub>S) Control) and Part Two, Section 16 (Manhole Drop Connections).



**c. Radius of the Channel.**

- 1) For sewer pipelines smaller than 12-inch diameter, provide a minimum radius of the centerline of the channel of one-half ( $1/2$ ) the inside diameter (ID) of the manhole, see Sketch "X".
- 2) For sewer pipelines 12-inch and larger, provide a minimum radius of the outer channel wall of one-half ( $1/2$ ) the inside diameter (ID) of the manhole, see Sketch "X".
- 3) Design the channels to have a uniform curve, with no reverse curves within the manhole.

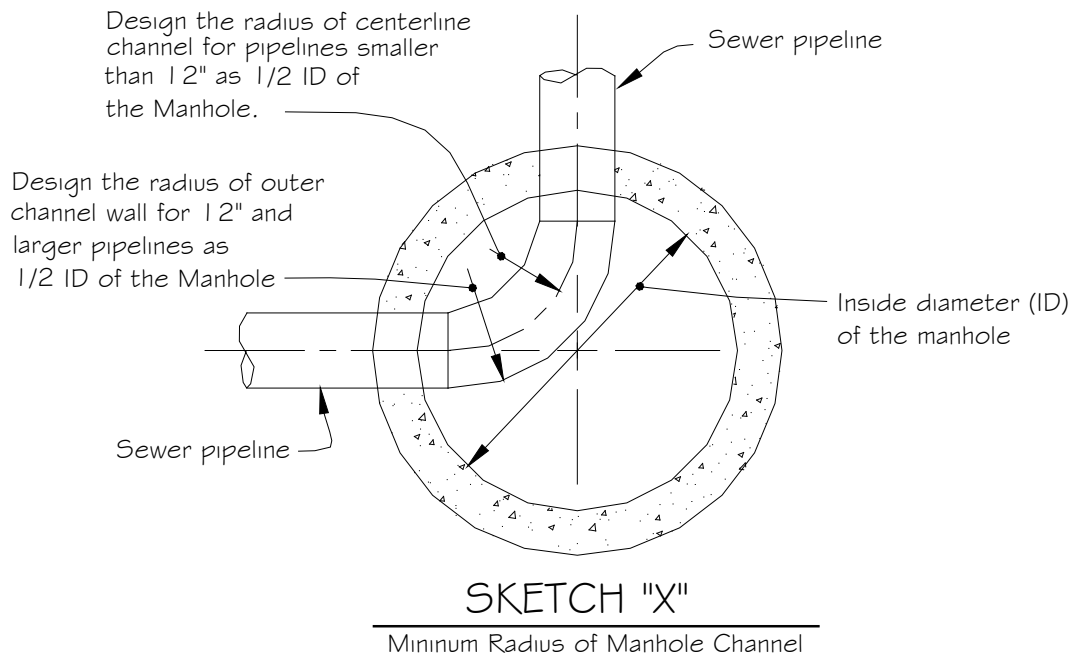
**Example:**

For a 48-inch diameter manhole for 8-inch sewers, minimum centerline channel radius equals two (2) feet.

**d. Width of Channel.**

- 1) The channel width for sewer pipelines having the same diameter entering and exiting a manhole is the same as the pipe inside diameter.
- 2) The channel width for sewer pipelines having different diameters is tapered from one pipe size to the other.

**e. Channels for 36-inch and Larger Diameter Sewers.**

- 1) Design manhole channel steps in the channel wall; see Standard Detail S/3.4.
- 2) Provide safety platform, when the width of the channel is inadequate or unsafe for a worker to



straddle the width of the open channel, the design may require a platform to bridge the channel for safety and for maintenance of the sewer and/or manhole. Size the grating platform so that it can be removed through the manhole openings, (frame and cover or hatch).

- 3) If the design requires flow control devices in the manhole, provide special details showing dimensions, sizes, etc., to layout the flow control devices in the manhole channel.

**f. Top of Bench Elevation.**

- 1) When both the incoming and outgoing pipes are the same diameter, set the top of bench at same as the top of pipe.
- 2) When the incoming and outgoing pipes have different diameters, set the top of bench at the top of pipe elevation of the highest pipe within the manhole, except when a manhole drop connection is designed. When a SHC entering the manhole is significantly higher than the mainline sewer, the bench on the side where the SHC enters may be elevated, and the bench on the opposite side may match the top of the mainline sewer for more convenient access.
- 3) If the HGL in the manhole is higher than the top of pipe within the manhole, set the top of the bench at an elevation of 3-inch above the HGL.
- 4) If the top of bench needs to be higher than the incoming or outgoing pipes, the top of bench elevation must be shown at the manhole on the profile.

**g. Width and Slope of the Top of the Bench.**

- 1) The bench should provide good footing for a worker and a place where tools and equipment can be laid and must **have** adequate slope to drain.
  - a) Design the top of bench with an eight (8%) percent or 1-inch per foot slope from the wall to the channel's edge.
  - b) Design the width of the bench to have a minimum of 12-inch on each side of the channel. If the width of the bench is not adequate, increase the diameter of the manhole.
  - c) Where space permits, the sewer can be offset to provide a wider bench on the side of the manhole that the steps are located on.
  - d) In cases when the manhole is existing and the design requires the channel to be increased, provide details on the drawings showing design of the modified channel.





## 18. Manhole Depth Design.

### a. General.

- 1) For design purposes, the manhole depth is measured from the top of the manhole frame and cover (rim) to the invert of the manhole (the invert of the channel at the center of the manhole).
- 2) Design all new manholes as precast concrete manholes.

### b. Precast Concrete Manholes.

- 1) Precast concrete manholes 48-inch diameter, see Standard Detail S/1.0, minimum depth of four (4) feet and maximum depth of twenty (20) feet, measured from the rim to the invert of the manhole. When the manhole depth is 4 feet or less, but not less than three (3) feet, provide a shallow type manhole, see Standard Detail S/3.2. Maximum pipe size for shallow type manholes is 12-inch diameter.
- 2) Precast concrete manholes 60-inch, 72-inch, 84-inch and 96-inch diameter, see Standard Detail S/1.1 for 60-inch diameter manholes and S/1.2 for 72-inch, 84-inch and 96-inch diameter manholes. Minimum depth of six (6) feet, measured from the rim to the invert, for 60-inch diameter manholes and four and one half (4-1/2) feet for 72-inch, 84-inch and 96-inch diameter manholes. When the manhole requires less than the minimum standards above, provide special details on the drawing modifying the Standard Details, see requirements under Part Three, Section 6 (Modifications to the Specifications and Standard Details).
- 3) For all precast concrete manholes provide the following, at the depths noted below.
  - a) For all size precast concrete manholes, when the depth exceeds sixteen (16) feet, a note must be provided on the drawings calling for pipe to manhole connections according to Standard Detail S/3.02.
  - b) For 48-inch diameter precast concrete manhole **where** depth would be twenty (20) feet or greater, instead provide a 60-inch diameter manhole and equip the manhole with a fall prevention system, see requirements in Part Two, Section 20 (Fall Prevention Systems).
  - c) **F**or 60-inch, 84-inch and 96-inch diameter precast concrete manhole **where** depth is twenty (20) feet or greater, equip the manhole with a fall prevention system, see requirements in Part Two, Section 20 (Fall Prevention Systems).
  - d) For all precast concrete manholes, **where** the depth would exceed twenty-four (24) feet, redesign the alignment so that the manhole depth is less than twenty-four (24) feet or request an exception from WSSC. If this exception is approved, include in the design of the manhole the following:
    - (1) Check the manhole for flotation, see requirements under Part Three, Section 4 Buoyancy of Pipelines).
    - (2) Verify that the exterior water pressure on the precast concrete manhole section joints from the ground water conditions will not exceed the requirements of ASTM C443 and the



## Specifications.

- (3) Verify that the water pressure on the pipe to manhole connections from the ground water conditions will not exceed the requirements of ASTM C 923 and the Specifications.
- 4) Precast concrete manholes built over existing sewer pipelines, for minimum and maximum depths of manhole diameters of 48-inch, 60-inch and 72-inch (Standard Detail S/2.0, S/2.1 or S/2.2), see above for precast concrete manholes.
- 5) Precast concrete manholes 84-inch and 96-inch diameter built over existing sewer pipelines - not directly covered by standard details, provide design on the drawing for the following:
  - a) When 84-inch and 96-inch diameter precast concrete manholes built over existing sewer pipelines are required, provide a reference to Standard Detail S/2.0, S/2.1 or S/2.2 and include a design on the plans for the bottom slab. Provide design calculations and details for the bottom slab of the built-over manhole; see requirements under Part Three, Section 6 (Modifications to the Specifications and Standard Details).
  - b) For minimum and maximum manhole depth requirements, see requirements for 72-inch diameter manholes built over existing sewers.

**c. Existing Brick Manholes.**

- 1) New brick manholes are not allowed, design all manholes as precast concrete.
- 2) When the design requires modifications to an existing brick manhole, use the following design guidelines to determine if the existing brick can be modified in place. If not, design the manhole to be replaced with a precast concrete manhole.
- 3) Do not connect new PVC sewer pipelines to existing brick manholes.
- 4) Existing brick manhole wall thickness, see Table "17".

**TABLE "17"**

Wall Thickness for Depth of Brick Manholes

Manhole Depth (to invert of manhole)	Required Thickness of Manhole Walls
Under 12'- 0"	8-inch
12'- 1" to 16'- 0"	12-inch
16'- 1" and over	Requires special design

- 5) Depth requirements for brick manholes:
  - a) When the depth exceeds the maximum depths for brick manholes, the following are required:
    - (1) When a brick manhole depth exceeds sixteen (16) feet, provide wall thickness design calculations/details.
    - (2) When 48-inch diameter brick manhole depth is twenty (20) feet or greater, provide a new 60-



- inch diameter precast manhole and equip the manhole with a fall prevention system, see requirements in Part Two, Section 20 (Fall Prevention Systems).
- (3) When 60-inch, 72-inch, 84-inch and 96-inch diameter brick manhole depth is twenty (20) feet or greater, provide a new 60-inch diameter precast manhole and equip the manhole with a fall prevention system, see requirements in Part Two, Section 20 (Fall Prevention Systems).
  - (4) For manhole depths exceeding twenty-four (24) feet, provide a diameter precast manhole and equip the manhole with a fall prevention system, see requirements in Part Two, Section 20 (Fall Prevention Systems).
- b) Minimum depths for existing brick manholes are as follows:
- (1) For 48-inch diameter brick manholes, eight (8) feet from the channel invert to the rim elevation.
  - (2) For 60-inch diameter brick manholes, eight feet four inches (8'-4") from the channel invert to the rim elevation.
  - (3) For 72-inch diameter brick manholes, nine feet three inches (9'-3") from the channel invert to the rim elevation.
  - (4) For 84-inch diameter brick manholes, eleven (11) feet from the channel invert to the rim elevation.



## 19. Manholes Built Over Existing Sewers.

### a. General Requirements.

- 1) When designing a new manhole over an existing sewer pipeline, see Standard Details S/2.0 and S/2.1. If existing sewer pipeline is PVC, see Standard Detail S/2.2.
- 2) Design the built-over manhole to maintain flow in the existing pipeline at all times.
- 3) For additional requirements, see Part Two, Section 7 (Relocating Sewer Pipelines).

### b. Design Requirements.

- 1) Design the built-over manhole as a **precast** manhole.
- 2) When cast in place manholes are to be designed over an existing sewer, see Part Two, Section 11 (Design of Structures).
- 3) Provide clearances between the OD's of the existing and proposed sewer pipelines, for the relationship between the two pipeline, see Part Two, Section 14 (Pipe to Manhole Geometry).
- 4) Design the channel to conform to Standard Detail S/3.3 and provide adequate space within the manhole for removal of existing pipe. Design the channel to suit the existing channel flow and provide adequate width at the top of the bench within the manhole for worker safety and maintenance, see requirements in Part Two, Section 17 (Manhole Channel Design).
- 5) The diameter of the manhole will depend on the requirements in Part Two, Section 14 (Pipe to Manhole Geometry).
- 6) For depth requirements, see Part Two, Section 18 (Manhole Depth Design).
- 7) Design manhole drop connections only for the new sewer pipeline entering into the built-over manhole.
- 8) When the existing pipeline is 12-inch or less above the new pipeline, slope the channel to suit; see Part Two, Section 17 (Manhole Channel Design). For differences over 12-inch, provide two manholes, one to be built over the existing sewer pipeline and the other to make up the difference in elevation.
- 9) When a manhole is built over an existing Asbestos Cement Pipe (ACP), abandon ACP following the requirements for abandonment of sewers in the Sanitary Sewage System Specification.



## 20. Fall Prevention Systems.

### a. General Requirements.

- 1) Provide a fall prevention system in any buried structure which exceeds twenty (20) feet depth. This includes tunnel access manholes, vaults, air release structures, blowoff structures, sewer manholes and junction chambers, etc.
- 2) Depth is measured from the top of manhole frame and cover (rim) to lowest invert elevation.
- 3) A Fall Prevention System consists of an aluminum ladder (see Standard Detail M/16.0) and a safety rail with rail extension kit in accordance with the Specifications.
- 4) Fall prevention systems to be aluminum. When sewerage structures are coated to prevent corrosion, verify to assure that aluminum is the proper material for the environment expected. If aluminum is not the proper material for the corrosive conditions, then provide a special design using appropriate materials.

### b. Design Requirements for Deep Manholes.

- 1) Provide the following design information on the drawings when the manhole depth exceeds twenty (20) feet:
  - a) Minimum 60-inch manhole diameter, [see Standard Detail S/1.4](#).
  - b) Aluminum ladder, see Standard Detail M/16.0.
  - c) Fall prevention system, see Specifications.



## 21. Adjusting Manhole Frames and Covers.

### a. General.

- 1) When the design requires the elevation of an existing frame and cover or hatch to be adjusted, the method of adjustment depends upon the material of the existing manhole (brick, precast concrete, or cast in place).

### b. Adjusting Existing Precast Concrete Manholes.

- 1) Provide the elevation of the top of the existing precast concrete manhole section (cone section or top slab) and new rim elevation, see requirements for setting frame and covers or hatches under Part Two, Section 11 (Design of Structures).
- 2) Method of manhole adjustment: In most cases the existing frame and covers can be adjusted by adding or removing bricks or concrete grade rings; this area is called the "transition". The transition is a minimum of 4-inches to a maximum of 18-inches; see Standard Details S/4.2 and S/4.3. If the transition cannot be adjusted, determine the vertical length of an existing precast manhole section that must be removed and the vertical length of a new precast manhole section that will be required to make the transition.

### c. Adjusting Existing Brick Manholes.

- 1) Determine the shape of the existing brick manhole (round, pear, square, etc.); the "H" dimension (rack/taper) of the existing manhole [see Standard Detail S/3.0 and Table "17", under Part Two, Section 18 (Manhole Depth Design)]; the elevation of the top of rack/taper; and the depth from the existing grade to invert of the existing manhole.
- 2) Method of brick manhole adjustment.
  - a) If the transition cannot be adjusted, the design must call for the reconstruction of the brick rack/taper or replacing the existing brick manhole with a new precast concrete manhole. In most cases, the existing brick manhole will have to be removed and a new manhole will have to be installed. Provide design calculations and details for adjusting existing brick manholes.
  - b) Review the depth of the manhole with Table "17", Part Two, Section 19 (Manhole Depth Design). If the manhole depth exceeds the allowable depth for a given wall thickness for brick manholes, as shown on Table "17", the design must include the removal of the manhole or replacement of the existing brick manhole with a new precast concrete manhole.
  - c) In most cases, the existing frame and cover can be adjusted by adding or removing the brick transition area. The transition is a minimum of 4-inches to a maximum of 18-inches; see Standard Details S/4.2 and S/4.3.

### d. Adjusting Existing Cast in Place Manholes.

- 1) The Designer will be required to verify that the existing cast in place manhole can be adjusted.
- 2) If cast in place manhole can be adjusted, see requirements for Adjusting Existing Precast Concrete Manhole in this section.



## 22. Impact of Storm Water Facilities on Existing Sewers.

### a. General.

- 1) Frequently, Storm Water Management (SWM) facilities are planned and designed to be constructed in close proximity to existing WSSC sewer pipelines and manholes. In these cases, precautions are required so that the proposed SWM facility (generally a storm water impoundment) does not adversely impact the operation, maintenance, and intended function of the sanitary sewer facilities and does not cause increased infiltration into the sewer system. The developer of a SWM facility is to locate any proposed impoundments and berms as far from WSSC facilities as possible.

### b. Coordination.

- 1) WSSC will coordinate the inspection of pipelines and appurtenances impacted by SWM facilities. If the existing pipeline requires relocation, assure that the design will not reduce the pipeline capacity and the new alignment does not create safety concerns, for example, access to structures and excessive depth of manholes.

### c. Requirements for Impact Assessment.

- 1) When existing sewer pipelines are within the site of a proposed SWM facility, determine the need for relocation or rehabilitation of the sewer in accordance with the following guidelines:
  - a) Existing manholes.
    - (1) Remove existing manholes within the pool required for the **ten (10)** year design storm floodpool.
    - (2) Rehabilitate as necessary, existing manholes within the one-hundred (100) year design storm floodpool to eliminate all significant inflow/infiltration points.
  - b) Existing sewer pipelines.
    - (1) Rehabilitate as necessary, existing sewer pipelines under the **ten (10)** year design storm floodpool to eliminate all infiltration points.
    - (2) Dam embankments may be permitted over or around existing sewer pipelines if the following is provided: Cost analysis showing the relocation around the embankment is more costly than protection of the existing pipeline; access is provided for equipment to maintain the pipeline; and an agreement to ensure the proper repair of the embankment by a suitable public agency in the event that WSSC has to excavate the embankment.
    - (3) If the existing sewer pipeline and manholes are to remain within the floodpool, request an inspection of the existing sewer pipeline and manholes through WSSC. WSSC will coordinate inspection and rehabilitation recommendations.
- 2) "Sewer Rehabilitation Procedure for Installing Stormwater Management Facilities Over Existing WSSC Sanitary Sewer Lines and Appurtenances".



- a) Pre-design inspection for manholes. Inspect existing manholes that fall within the **one-hundred (100) year design storm** floodpool and make recommendations for the manholes. The following are typical recommendations:
  - (1) Leave existing manhole as is.
  - (2) Insure watertight frame and cover is bolted and sealed on the existing lead, or silicone seal older covers.
  - (3) Provide waterproof parging or other exterior waterproof coating to the existing manhole.
  - (4) Provide an interior waterproof sealant within the existing manhole.
  - (5) Ensure watertight pipe connections at the existing manhole.
  - (6) Replace existing manhole, as it is beyond repair.
  - (7) Remove existing manhole and relocate existing sewer pipeline.
- b) Pre-design inspection for sewer pipelines. Using television inspection of the existing sewer pipelines within the **ten (10) year design storm** floodpool, make recommendations for the sewers. The following are typical recommendations:
  - (1) Leave existing sewer pipeline as is.
  - (2) Spot repair infiltration points.
  - (3) Line existing sewer pipeline in its entirety.
  - (4) Relocate existing sewer pipeline.
- c) Note any existing manholes, or existing sewer pipelines that lie within the earth embankment area and make written recommendations for removal.
- d) If the proposed embankment would be located over the existing sewer, make a cost analysis of the recommended treatment versus relocation of the existing sewer pipeline around the embankment. Final determination will be made by the WSSC.
- e) Submit all recommendations to WSSC. Once approved by WSSC, incorporate the recommendations in the SWM constructions plans.





## 23. Relief Sewer Design.

### a. Interaction of Relief Sewer with Existing Sewer.

- 1) Relief sewer design. Determine how the design flow will be routed. The topography, available outlets, and available head may dictate which alternative is selected. Three (3) alternatives for relief sewer design are as follows:
  - a) Flow is divided between the existing and relief sewer;
  - b) Flows in excess of a predetermined quantity are diverted to the relief sewer;
  - c) A predetermined flow from the upper end of the system is diverted to the relief sewer.
- 2) An examination of the flow quantities in the existing and relief sewer may determine the method of relief. If on the other hand, the relief sewer is designed to take flows in excess of a fixed quantity, the relief sewer itself will stand idle much of the time and solid deposits are likely. Judgment is required in deciding which relief alternative is most appropriate. In some cases, the best alternative may be to make the new sewer large enough to carry the total flow and abandon the old one.
- 3) Diverting the flows.
  - a) If the flows are divided according to a predetermined ratio, the inlet structure to the relief sewer must be designed to divide the flow.
  - b) If the relief sewer is to take all the flows in excess of a predetermined quantity, the excess flow may be discharged over a weir to the relief sewer.
  - c) If a predetermined quantity is to be diverted in the upper reaches of the system, the entire flow at the point of diversion may be sent to the relief sewer or the flow may be divided in a diversion structure.
- 4) The design of the relief sewer must maintain a self-cleansing velocity of a minimum of two and one half (2.5 fps) feet per second, see Hydraulic Design of Relief Sewers, in this section. Determine the flow ratio between the relief sewer and the existing sewer and indicate this information on the drawings.
- 5) The extent of the existing sewer line to be relieved will be determined by WSSC.

### b. Flow Distributions.

- 1) Determine how the initial flows will be distributed and what changes are needed to redistribute the ultimate flows. The flow quantity for both the initial and ultimate flow must be noted on the drawings.



## 2) Devices to regulate flow.

- a) A weir can be designed to divert flows in excess of predetermined flow or ratio of flow. Weirs can be either a permanent weir or temporary/adjustable weir.

(1) Permanent weir.

- (a) Design a brick or concrete weir (same material as the channel).
- (b) Minimum of 12" wide at the top of weir, with a side radius slope to the channel invert the same as the diameter of the relief sewer piping and channel, see Sketch "Y".
- (c) Indicate on the drawings the elevation of the top of the weir and the weir material.

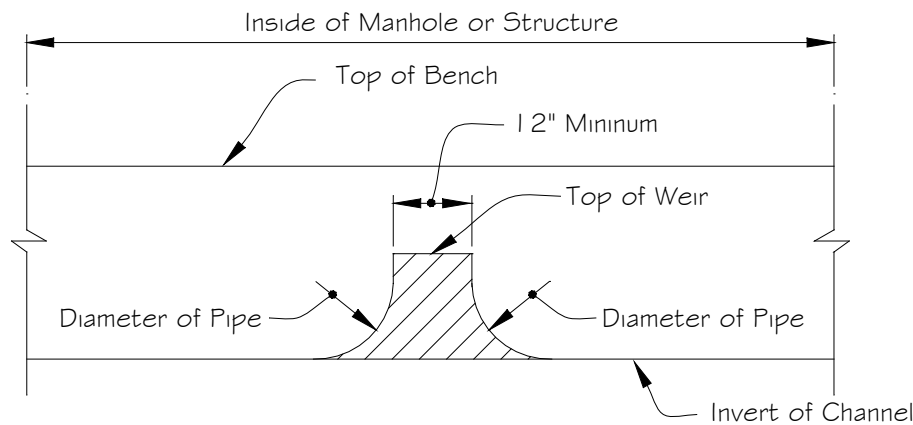

SKETCH "Y"

Relief Sewer - Flow Control Device (Weir)

(2) Temporary/adjustable weir.

- (a) Design a weir plate, using an aluminum plate with lifting handles.
- (b) The channel at the weir plate must be designed to suit the guide frame of the weir plates. Typically the weir plates are non-circular and the channel must be designed to transition from a circular channel to a flat bottom channel at the weir.
- (c) Indicate on the drawings, the elevation at the top of the weir.
- (d) If the design requires the weir to have adjustable height for flow control, provide the capacities for each weir plate.
- (e) Provide storage hooks on the manhole or structure wall to store the plates when they are not in use.
- (f) Lifting hooks above the weir plate location at the channels must be designed and provided on the underside of the top slab.



- b) To divert all the flows from the existing sewer to the relief sewer, design the diversion structure with a slide gate.
  - (1) Design the slide gates and their frame to suit the channel. Typically the slide gate is non-circular and the channel must be designed to transition from a circular channel to a flat bottom channel at the weir.
  - (2) Provide all manufacturers' catalog material for slide gates and frames.

**c. Junction Chambers, Structures or Manholes.**

- 1) For the design guidelines for junction chambers, structures or manholes, see Part Two, Section 11 (Design of Structures).
- 2) In addition to the above requirements, provide the following:
  - a) Removable grating platform with access openings for the devices to regulate flows. The platform must be above the top of the bench and a minimum of **six (6) inches** above the hydraulic gradient of the design flow of the sewers.
  - b) Minimum of six and one half (6-1/2) feet of head room.
  - c) Channel design with all dimensions, sizes, shapes, slopes, etc.

**d. Horizontal Alignment.**

- 1) For general horizontal alignment requirements, see Part Two, Section 5 (General Horizontal Alignment).
- 2) For most cases, the location of the relief sewer is designed parallel to the existing sewer. Determine the spacing requirements between the two pipelines and the total working area required, (**easement** and construction strips). Consider the following to determine the required construction area:
  - a) The construction area over the existing sewer must not impose any additional loading on the pipe which includes heavy construction equipment, trench excavation, etc., unless calculations are submitted showing the existing sewer will not be damaged by the additional loading.
  - b) Area required for stockpiling materials along the alignment. Items that are considered to be stockpile materials include storing the pipe along the trench, storing stone and gravel, and storing excavated trench material, etc.
  - c) Contractor access road. This area must be left open at all times.
  - d) Trench width.
  - e) Area for construction equipment on the side of the trench.



- f) Minimum spacing requirements between relief sewer and original sewer pipelines; see Part Three, Section 3 (Pipeline Crossings and Clearances).
- g) Minimum work area on the side of the relief sewer, opposite of the existing sewer, is twenty-five (25) feet. This area can be a combination of the **easement** and **a** construction strip.

**e. Vertical Alignment.**

- 1) For vertical alignment and profiles, see requirements under Part Two, Section 8 (Vertical Alignment-Profiles).

**f. Design Flows for Both Systems.**

- 1) Show the design flows (Q) on the profile at all connecting sewer manholes, changes in pipe sizes, changes in pipe slopes, and any other locations that will change the capacities will occur. These flows are ultimate design flow.

- a) Design flows for both pipelines.

(1)  $Q^{\text{Design Relief}}$  = the design flow for the relief sewer

(2)  $Q^{\text{Existing Sewer}}$  = the design flow for the existing sewer

- b) Design capacities of both the pipelines.

(1)  $Q^{\text{Pipe Relief}}$  = the design capacity of the pipe for the size and slope of the relief sewer

(2)  $Q^{\text{Pipe Existing}}$  = the design capacity of the pipe for the size and slope of the existing sewer

- c) See Hydraulic Design of Relief Sewers, in this section.

**g. Hydraulic Design of Relief Sewers.**

- 1) Flow rates.

- a) Determine the flow rate using the existing range of flow rates (existing average, existing peak) and future flow rates (ultimate [future] minimum, ultimate [future] average, and ultimate [future] peak), consult WSSC.

- b) Evaluate hydraulic limitations of the existing sewer. This will include an evaluation of the existing sewer capacity, flow velocities, downstream controls/outfall conditions, and overflow points.

- 2) Preliminary hydraulic **analysis** includes:

- a) Relief sewer design alternatives. Specify the extent of the relief sewer and the locations of tie in with the existing sewer at the upstream and downstream ends of the relief sewer. Evaluate the method of providing relief capacity for the existing sewer. The choice of the method of relief can depend on several factors such as peak and minimum flows, velocities in the existing



and proposed sewers, topography, available head, and downstream control/outfall conditions. Consider the following alternatives:

- (1) The proposed relief sewer is designed to divert part of the total flow from the upper reaches of the system. This may require more than one point of flow diversion/distribution.
  - (2) The proposed relief sewer is designed to divert all flows in excess of a certain quantity, which may be determined by the capacity of the existing sewer, or the flow at which the minimum flushing velocity is attained.
  - (3) The proposed relief sewer is designed to accommodate all rates of flow in combination with the existing sewer. This may require the design of an inlet structure at the upstream end or more than one interconnecting junction structure for the system to divide the flows.
- b) Estimate flows (minimum/maximum) to be conveyed by each sewer line. These flows may vary along the length of the sewer lines.
  - c) Provide preliminary sizing of the relief sewer based on available head and proposed flows.
    - (1) Size the relief sewer flow for open channel flow conditions, using Manning's equation.
    - (2) A surcharged flow condition is not desirable for a gravity sewer. Use Manning's friction factor of 0.013 (minimum) for new pipes, and reflect the type of pipe material and increase of friction factor due to aging of the sewer pipes.
  - d) Provide preliminary HGL profiles for each sewer line for the range of flow rates. Include backwater effects from the downstream control location and significant headlosses at manholes and interconnecting structures.
  - e) Estimate the minimum/maximum flow velocities in each sewer line for the range of flow rates considered. The minimum velocity of two and one half (2.5) fps for gravity sewers **must** be achieved daily.
  - f) Determine the method of flow diversion and distribution. The use of transverse weirs, side-overflow weirs, orifices, baffles, sluice gates, proportioning flow channels, etc., may be considered. Adjustable devices may be required to allow for flow adjustment.
  - g) Provide hydraulic design of flow diversion/distribution structures. For preliminary design, the flow diversion/distribution devices may be sized assuming open channel flow conditions prevail in the downstream sewer segments. Estimate headlosses and the HGL elevations of the merging flow streams should match inside the interconnecting structure. The total number of such structures should be minimized.
- 3) Detailed hydraulic analysis. Complete by the final design a detailed hydraulic analysis. Incorporate any changes and modifications made to the preliminary design. Consider the following guidelines:
    - a) Base the final calculations of backwater profiles/HGL profiles for the sewer system on the step backwater profile calculation methods to account for any backwater effects due to downstream



control and energy losses at manholes, interconnecting structures and pipe friction. Calculation of energy losses at manholes or interconnecting structures must be done individually for each structure. The purpose of these calculations is to ensure that the sewer pipeline would be operating under open channel flow conditions at design flows. The starting location and hydraulic grade in the existing downstream sewer for the backwater profile analysis will be provided by WSSC. Provide references for the method employed for energy loss calculation at the manholes and structures. If a computer program is used, provide adequate information to show that the program computes the backwater profile accurately.

- b) Headlosses at manholes and interconnecting structures should be minimized. These losses can be caused by abrupt flow expansion and contraction due to improper channel design, changes in flow direction, changes in flow velocities due to differences in upstream and downstream pipe size/slope, changes in flow quantity and losses at flow control devices. It may be necessary to compensate for these losses in order to avoid surcharge flow conditions.
  - c) Check the design of the flow diversion or distribution devices by incorporating any backwater effects from the downstream sewer segment, based on the HGL profiles developed.
  - d) If surcharged flow conditions cannot be avoided, plot the HGL profile associated with the maximum design flow on the pipeline profile.
  - e) High velocity transitions in interconnecting structures should be avoided so as to minimize excessive turbulence and headlosses, especially for structures where there are flow diversions or distribution devices.
  - f) If more than one pipe enters an interconnecting structure, it is necessary to design the transition such that flow streams from individual influent sewers can blend together without abrupt changes in water surface elevations. It is desirable to keep the velocities of the incoming flows approximately the same.
- 4) Identify and shown on the drawings, for each sewer pipeline that discharges into a downstream wastewater pumping station, the location and elevation of the wastewater overflow point, as a result of an inoperative wastewater pumping station.
  - 5) Submit the drawings and detailed final hydraulic calculations in support of the relief sewer design.



## 24. Force Main Design.

### a. Alignment - Horizontal and Vertical

- 1) Locate the force main as if it is a water pipeline, see requirements under Part One (Water), with the following exceptions.
  - a) When adjacent or parallel to a water pipeline, design the force main in accordance with the requirements of the sewer pipelines, see Part Three, Section 3 (Pipeline Crossings and Clearances). Do not provide concrete encasement of the force main.
  - b) When the force main alignment is running parallel to a sewer pipeline, see the following requirements:
    - (1) Where the sewer is existing, design the force main in accordance with the requirements of relief sewers under Part Two, Section 23 (Relief Sewer Design) and Part Three, Section 3 (Pipeline Crossings and Clearances).
    - (2) Where the sewer is not existing, see Part Three, Section 3 (Pipeline Crossings and Clearances).
  - c) Provide minimum vertical slope on the pipeline in profile: provide one tenth (0.1) of a foot in fifty (50) feet of vertical alignment for pipelines 12-inch and smaller and one tenth (0.1) of a foot in one hundred (100) feet of vertical alignment for pipelines larger than 12-inch.
- 2) For force mains in tunnels or casing pipes, see requirements under Part One, Section 18 (Tunnels or Casing Pipes).

### b. Profile Requirements.

- 1) See the requirements under Part One, Section 11 (Vertical Alignment - Profile).
- 2) Show the HGL on the profile for the design of the force main or provide a table on the plans, providing the HGL elevation every fifty (50) feet along the length of the force main.
- 3) Design the top of the force main and its appurtenances, such as air release, and air and vacuum valves, lower than the HGL.
- 4) Ideally, the force main should be designed without intermediate high points, and with the top of the force main being below the hydraulic grade line at the minimum pumping rate so that air release valves will not be needed. If the elimination of high points is not feasible or if the design requires air and vacuum valves, for long, relatively flat vertical alignments, the design may require air release and air and vacuum valves, see requirements under Part Two, Section 26 (Air Valves).



**c. Allowable Pipe Material and Fittings.**

## 1) Allowable pipe material.

a) DIP. For requirements using DIP, see Part One, Section 4 (Selection of Pipe Material) with Sections 2 (Pipe Material and fittings) and 4 (Selection of Pipe Materials). All DIP Fittings see Part One, (Pipe and Fittings) with special interior ling, see Specifications.

b) AWWA C900 PVC. May be used for force mains in diameters 12-inch and smaller as an alternative to DIP if the PVC pipe meets the external load and internal pressure requirements, as stated in this section.

(1) Pipe dimension ratio for AWWA C900 PVC. The use of PVC for force mains is limited by the pipe diameter, operating pressure (including pump cyclic loading), and pipe dimension ratio (DR) as follows:

(a) AWWA C900 DR14, total allowable internal, pressure operating and surge pressure is less than two hundred (200) psi, except as noted in Pumping cyclic loading, in this section.

(b) Pumping cyclic loading.

[1] The on/off operation of pumps creates a cyclic loading, which may limit the total allowable pressure in the force main. Information on cyclic loading is available from the PVC PIPE Association – Handbook of PVC.

[2] Confirm the number of pump "on" and "off's" during the life of the force main and submit calculations indicating whether total allowable pressure has to be reduced to account for cyclic loading. For purposes of this design criteria, use the following equations for finding the total allowable internal pressure:

DR14 pipe. The maximum total internal pressure =  $3618 \div C^{0.204}$

Where C is the number of pump "on" and "off's" during the life of the force main.

Example: Assuming a pump operates twice per hour (4 "on" and "off's") 24 hours per day, 365 days per year for 75 years.

Then  $C = 4 \times 24 \times 365 \times 75 = 2,628,000$ .

The maximum total internal pressure =  $3618 \div 2,628,000^{0.204} = 177$  psi.

The above equation for the DR14 for cyclic loading include a derating factor assuming a wastewater temperature of 80 degrees.

(2) Allowable cover for AWWA C900 PVC.

(a) AWWA C900 DR14, allowable cover is twenty five (25) feet. If the DR 14 pipe is encased in granular material in accordance with the Specifications for PVC Gravity Sewer Pipe and Standard Detail M/8.1a, maximum allowable cover is forty (40) feet: see Standard Detail W/6.1.

(b) The allowable cover with native bedding/backfill is based on a soil modulus of 0,





deflection lag factor of 1.0, earth load calculated as prism load, and maximum allowable deflection 2.5%.

- (3) Information required on the Drawings.
  - (a) Indicate the allowable type(s) of pipe; DIP and/or AWWA C900 PVC.
  - (b) If AWWA C900 PVC is allowed, the specifications require DR14 pipe, unless noted otherwise on the drawings. Calculate the maximum operating pressure and surge, and assure that the operating and surge pressure is less than two hundred (200) psi and adjusted for cyclic loading. In considering surge, note that the modulus of elasticity of PVC is much less than that for DIP and therefore, for a given change in velocity, the resulting surge is less for PVC than DIP. Consult the [PVCPIPE Association – Handbook of PVC](#) for additional information.
  - (c) If granular material bedding is required due to the depth of cover, see "Allowable cover for AWWA C900 PVC" in this section, and include a note to provide bedding for the PVC according to Standard Detail M/8.1a.
- c). High-Density Polyethylene Pipe (HDPE) for 12-inch and smaller force mains.
  - (1) Pipe Dimension Ratio (DR)
    - (a) ASTM F714/AWWA C906, DR-11
    - (b) For HDPE, total allowable internal pressure, operating plus surge, not to exceed one hundred thirty (130) psi.
    - (c) HDPE pipe OD equals DIP OD. The Designer must consider difference in pipe ID and OD when using HDPE pipe.
    - (d) Allowable cover for HDPE DR-11 is twenty five (25) feet.
  - (2) Method of Construction
    - (a) HDPE pipe can be installed in open-cut only.
    - (b) HHD will require the contractor to test pit along the alignment every one-hundred (100) feet, see Specifications.
  - (3) Joints and thrust restraint.
    - (a) HDPE- Joined by thermal butt-fusion or electrofusion and is consider restrained.
    - (b) HDPE has a very high coefficient of thermal expansion/contraction. To prevent pullout of the HDPE pipe from an unrestrained joint because of contraction due to change in temperature, a thrust collar is installed on the HDPE pipe adjacent to the manhole, see Standard Detail PS/3.1.



- (4) Horizontal and vertical alignment, see requirements under in this section under Force Main Design, except for the following:
- (a) For minimum radius of curvature for HDPE force mains, see Table "18". Radius of curvature at low points should be maximized.

**TABLE "20"**  
Minimum Curve Radius for HDPE Force Mains

Pipe Size	Minimum Radius
4-inch	130 feet
6-inch	200 feet
8-inch	270 feet
10-inch	330 feet
12-inch	400 feet
14-inch	470 feet
16-inch	530 feet
20-inch	670 feet
24-inch	800 feet

- (b) Do not design ninety (90°) degree bends in the pipeline alignment.
- 2) Allowable fittings for AWWA C900 PVC and HDPE.
- a) AWWA C900 PVC
- (1) Limit the type of fittings on the force main to only bends; see allowable fitting requirements under Part One, Section 7 (Allowable Fittings).
  - (2) Use only DIP Fittings; see allowable fittings in accordance with Part One, Section 2 (Pipe Materials and Fittings) and with special interior ling, see Specifications.
- b) HDPE
- (1) Fittings on HDPE
    - (a) Electrofusion coupling only for Air Release Manhole
    - (b) DIP fittings, see allowable fittings in accordance with Part One, Sections 2 (Pipe Materials and Fittings) and 3 (Pipe and Fittings) with special interior ling, see Specifications.
 

[1] DIP Fittings diameters does not match HDPE pipe outside diameter. Determine the correct diameter of DIP fittings for HDPE pipe.



3) Thrust restraint for AWWA C900 PVC and HDPE.

a) AWWA C900 PVC

- (1) For thrust restraint, concrete thrust blocks are the preferred method of restraint. If blocking is not possible, restrained joints may be used, see "Allowable fittings for AWWA C900 PVC", in this section.
- (2) Design the thrust restraint, in accordance with Part Three, Section 27 (Thrust Restraint Design for Buried Piping).

b) HDPE

- (1) HDPE- Joined by thermal butt-fusion or electrofusion and is consider restrained.
- (2) HDPE has a very high coefficient of thermal expansion/contraction. To prevent pullout of the HDPE pipe from an unrestrained joint because of contraction due to change in temperature, a thrust collar is installed on the HDPE pipe adjacent to the manhole, see Standard Detail PS/4.0.

4) Design criteria for AWWA C900 PVC.

- a) Design the PVC C900 pipeline without curves using fittings only. See Part One, Section 12 (Allowable Joint Deflections) and Part One, Section 14 (Joint Deflections at Fittings).
- b) Field bending of PVC pipe is not permitted and the manufacturers' allowable PVC pipe joint deflection is limited. See Part One, Section 13 (Allowable Joint Deflections).

**d. Appurtenances and Structures.**

- 1) Air release, and air and vacuum valves, see requirements under Part Two, Section 26 (Air Valves) and Profile Requirements, in this section.
- 2) Blowoffs.
  - a) Locate blowoffs near the wastewater pumping station. The wastewater pumping station bypass piping may be used to blowoff the force main piping, see WSSC Design Guidelines for Wastewater Pumping Stations (DG-06).
  - b) Blowoffs along the force main normally are not required; however, where the force main contains a long depressed section between two high points or in case the force main needs a point to drain the system, WSSC may require a blowoff. The design of blowoff piping consists of a valve connection on the force main and piping to either a gravity sewer manhole or to a manhole so that a pump can be used to drain the force main to a gravity sewer manhole, tank truck, etc.
- 3) Provide flushing connections on the force main if required by WSSC. Design the flushing connection to allow WSSC to clean the force main. WSSC will determine the size and spacing, if required.



- 4) Transition manhole.
  - a) Design the connection between the force main and gravity sewer with a transition manhole so that wastewater will be flowing full at all times in the force main. Typically, the invert of the gravity sewer will be one (1) inch above the crown or top of the force main.
  - b) For force mains smaller than 12-inch in diameter, see the WSSC Standard Detail S/6.6.
  - c) When the force main is 12-inch and larger, provide a design for the transition manhole with a connection to the manhole that will allow the force main to remain full at all times. The design must also protect maintenance personnel or others from falling in the pipeline because of the steep slope required for the channel when larger force mains are used.
  - d) Hydrogen Sulfide (H<sub>2</sub>S) corrosion mitigation.

- (1) Transition Manholes

- (a) See the Specifications for interior coatings and specify on the drawings the limits of interior coating for the transition manhole, at least one-hundred (100) feet of the force main before the transition manhole and distance from the transition manhole along the gravity sewer pipeline if it is other than PVC pipe. The minimum distance along the gravity sewer pipeline is to the next manhole for the interior coating, but the design may require several downstream manholes and pipeline sections to have interior coatings, see Specifications for transition manholes.
- e) PVC AWWA C900 and HDPE force mains require a tracer wire on top of the PVC AWWA C900 or HDPE pipe, in accordance with the Specifications.
  - (1) The tracer wire shall be placed on top of the PVC AWWA C900 pipe and to be connected to a Continuity Test Stations; see Standard Detail W//9.0.
    - [1] Locate Continuity Test Stations next to all vaults and manholes; see Standard Details W/9.0.
    - [2] If spacing between Continuity Test Stations is over eight hundred (800) feet, provide Continuity Test Stations every five hundred (500) feet; see Standard Details W/9.0.
    - [3] Locate Continuity Test Stations at every connection to existing force mains; see Standard Details W/9.0.

- e. **Hydraulic Design of Force Mains.**

- 1) Guidelines for hydraulic design of force main are as follows:
  - a) The design of a sewage force main must be coordinated with the design of the wastewater pumping station. Provide a design criteria report, which discusses the range of design flow for the planning period, the proposed design of the pumping station, and the force main as a unified system.



- b) Develop the proposed alignment in plan and depict the changes in force main elevations in profile.
- c) The number of air valve installations should be minimized. This can be achieved by reducing the number of high points and slope breaks, and by using a profile that rises continuously from the pumping station toward the transition manhole. This allows the use of air injection as a method for the control of hydrogen sulfide ( $H_2S$ ) corrosion and odor problems, if necessary.
- d) Develop the system curve for the force main, which shows the total energy losses associated with the range of possible pumping rates. Using the system curve, develop the HGL profiles.
  - (1) Use Hazen-Williams (HW) equation for estimating friction losses; HW friction factors applicable for the type of pipe material and age of the force main. Since the friction factor cannot be exactly defined for a new design, two values of HW friction factors may be selected to cover a range of possible pump operating points. Incorporate minor losses at transitions and bends. Darcy-Weisbach equation may be used as an alternative.
  - (2) Develop HGL profiles for the range of pumping rates (minimum, average and maximum rates) planned for the pumping station.
  - (3) For calculating friction losses in an existing force main, existing flow and pressure data, if available for the force main and pumping station system can be used to determine the HW friction factor.
  - (4) Base the static head on the difference in vertical elevations between the wet well low operating level and the point of force main discharge to the gravity sewer.
- e) It is desirable to minimize the length of the force main so as to minimize the cost of construction and operation.
- f) Vertical alignment.
  - (1) Uphill pumping is preferred in a force main, where the force main discharge point to the gravity sewer is at a higher elevation than the rest of the system, so as to keep the force main under pressure.
  - (2) If an intermediate high point in the force main lies above the downstream point of the gravity discharge, a partial vacuum condition can be created at the high point, when the force main drains after pumps shut off and when the HGL profile drops below the high point.
  - (3) Downhill pumping, vertical profiles which are conducive to siphoning at high points and gravity drain/air locking in downhill pumping conditions will require special analysis to ensure proper hydraulic performance. These types of force main profiles are also conducive to potential severe waterhammer pressures caused by rapid velocity change in the force main resulting from pump start up or shut down. It is therefore recommended that force main profiles which can generate downhill flow be avoided. If downward pumping condition cannot be avoided, then proper hydraulic performance of the force main should be ensured based on sound engineering and design principles. Consider the following, when downhill pumping is required.



- (a) The downward sloping force main section following the high point may not flow full during initial line start up because the flow carrying capacity exceeds the line filling rate. The elevation of the high point, in this case, will give the highest static head that the pump must overcome during initial start up.
- (b) The downward sloping force main section may not flow under pressure at some pumping rates during normal operation of the pumping station and when pumps shut down. Consider whether and how the pressurized pipe flow should be achieved and maintained.
- (c) The extent and effects of partial vacuum condition/siphon action on force main hydraulic performance. Consider allowing the partial vacuum condition during normal conditions and how is it maintained.
- (d) The trapping of air/sewer gases at the high point and the downward sloping section, and the effects on pumping head and removal of the air/gas from the force main.
- (e) Potential waterhammer pressure due to pump shutdown or power failure.
- g) In general, a minimum velocity of two (2) feet per second (fps) is required to maintain solids in suspension. Velocities ranging from three (3) to three and one half (3.5) fps would be required to re-suspend solids that have settled in the force main. This higher velocity is required for force main profiles which exhibit multiple high points and low points. Relatively small stations with intermittent pumping of one or two pumps generally should be designed for higher minimum velocities in the force main, compared to larger stations having more than three pumps. The minimum velocity required must be based on engineering as well as operation and maintenance considerations.
- h) The maximum velocity in a force main is about six (6) fps. High velocities generating high headlosses and potential severe waterhammer pressures are not desirable. Flow velocity can vary in a force main, depending on the number of pumps operating in a pumping station. Base the maximum force main velocity on the peak pumping rate that would be delivered during the peak wastewater influent condition.
- i) The minimum size for a force main size is 4-inch diameter.
- j) Evaluate the severity of waterhammer pressures in the force main under the worse case scenario assuming power failure at the pumping station coincident with firm pumping capacity. Upon power failure at the pumping station, severe down surge (low pressure) can propagate throughout the entire force main, followed by upsurge (high pressure). Examine potential for water column separation in the force main. Methods of waterhammer pressure control and relief should be incorporated, if necessary.
- k) Consider the operating pressure and the surge pressure in designing thrust restraint for the force main, see Part Three, Section 27 (Thrust Restraint Design for Buried Piping).
- l) Submit drawings, details and final hydraulic calculations to support the force main design.



**f. Hydraulic Transients.**

Hydraulic transients are the time-varying phenomena that follow when the equilibrium of steady flow in a system is disturbed by a change of flow that occurs over a relatively short time period.

- 1) Surge Control for Raw Sewage Force main: The strategies for controlling surge in raw sewage force main/ sewage pumping stations are limited as compared to the pumping of clean water, because some of the valves (globe and butterfly, for example are unsuitable, the reliability of other valves (such as vacuum and air release) depends on frequent and vigilant maintenance, and air chambers are far more maintenance-dependent for sewage than for water. However adequate control strategies remain and any proposed solution should be checked thoroughly.
- 2) Transients are important in hydraulic systems because they can cause rupture of pipe and pump casings, pipe collapse, vibration, excessive pipe displacements, pipe fitting and support deformation /failure, vapor cavity formation, cavitations and column separation. There is no simple, easy way to perform reliable transient analyses. Computer modeling is the most effective means available, but there are practical constraints on time and cost. Every pump and pipeline system is subject to transient pressures, but it is impractical to spend the time and expense necessary to analyze all of them. The following guidelines can be used to decide whether a complete transient analysis is required or not:
  - a) Do Not Analyze:
    - (1) Pumping station with flow rate less than 100 gal/min. discharge piping is usually such that velocity is low and transient pressures are low.
    - (2) Pipelines in which the velocity is less than 2ft/sec.
    - (3) Pumping systems with a static differential pressure between suction and discharge of less than 30 ft. Warning: it is possible that a very low static head coupled with a relatively high dynamic head could result in a column separation problem.
  - b) Do Analyze:
    - (1) Pumping systems with a total dynamic head greater than 50ft if the flow rate is greater than 500 gal/min.
    - (2) High lift pumping systems with a check valve, because high surge pressures may result if the check valve slams shut upon flow reversal.
    - (3) Any system in which column separation can occur:
      - (a) Systems with “knees” (high points).
      - (b) A force main that needs automatic air venting or air-vacuum valves.
      - (c) A pipeline with a long (more than 300ft.), steep gradient followed by a long, relatively flat gradient.



- 3) A serious surge may occur if any one of the following conditions exists and if two or more conditions exist, a surge will probably occur with a severity proportional to the number of conditions met:
- a) High spots in pipe profile.
  - b) Steep gradient: Length of force main less than 20 TDH.
  - c) Flow velocity in excess of 4 ft/sec.
  - d) Factor of safety (based on ultimate strength) of pipe (and valve and pump casing) less than 3.5 for normal operating pressure.
  - e) Slowdown and reversal of flow in less than  $t_c$  (Critical Period, sec.).

The critical period ( $t_c$ ) is the roundtrip time of travel of the pressure wave from and back to the point of flow change and is given by the following equation:

$$t_c = 2L/a, \text{ where}$$

$L$  = length of force main between point of flow change and point of reflection, (ft) and

$a$  = velocity of pressure wave, (ft/sec.).

The velocity of a water hammer pressure wave depends on the physical properties of the fluid and the force main pipe, and the acceleration due to gravity. It can be calculated with the following equation:

$$a = \frac{4720}{\sqrt{1 + C1(kd / Ee)}} \text{ (U.S. customary units)}$$

$C1 = 1$ , for pipe with expansion joints throughout

=  $1 - \mu^2$  for pipes anchored against axial movement (buried force mains, for example)

=  $5/4 - \mu$ , for pipes without expansion joints and anchored at the up-stream end

$\mu$  = Poisson's ratio

$k$  = bulk modulus of water, taken as 300,000 Ib/in<sup>2</sup>

$d$  = pipe diameter, in

$E$  = modulus of elasticity of pipe material, Ib/in<sup>2</sup>

$e$  = thickness of pipe wall, inches

- f) Check valve closure in less than  $t_c$ .
- g) Any valve closure (or opening) in less than 10 sec.
- h) Damage to pump and motor if allowed to run backward at full speed.
- i) Pump stopped or speed reduced to the point where shut-off head is less than static head before the discharge valve is fully closed.
- j) Pump started with discharge valve opened.





- k) Booster stations that depend on operation of main pumping station.
- l) Presence of quick-closing automatic valves that becomes inoperative if power fails or pumping system pressure fails.

4) References

Fluid Transients in Systems (Wylie & Streeter),

Collection and Pumping of wastewater (Metcalf & Eddy, INC)

Pumping station design (Robert L. Sanks).

**g. Field Testing Requirements for Force Mains.**

- 1) According to the Specifications, a contractor is required to field test newly constructed sewage force mains to pressures indicated on the drawings or in the special provisions. Develop the required test pressures based on operating and surge pressures and indicate them in the contract documents. This may require the calculation of these numbers based upon force main configuration and pump characteristics. Some of the information required to develop these numbers may be obtained from the pumping station design or found in the contract documents for the pumping station. Submit documentation for calculations for test pressures, for approval by WSSC.

**h. Required Analysis for Hydrogen Sulfide (H<sub>2</sub>S) Generation and Release.**

- 1) Generation.
  - a) Perform the analysis for the proposed design indicated in Part Two, Section 28 (Hydrogen Sulfide (H<sub>2</sub>S) Control) to determine the potential for hydrogen sulfide generation.
  - b) Design the system piping layout to minimize the total piping lengths and pipe sizes within the constraints of the hydraulic design criteria, so as to minimize sewage detention time in the system. Downhill pumping conditions with a high point above the transition manholes will potentially cause the release and accumulation of hydrogen sulfide gas at the high points. Avoid high points in the design, if possible.
- 2) The discharge of sewage from a force main into a gravity sewer can potentially generate odor and the release of hydrogen sulfide at the transition manhole and in the downstream gravity sewer. Turbulence in the transition manhole should be minimized. Consider in the design and selection of gravity sewer pipe material downstream of transition manholes, corrosive effects of hydrogen sulfide, see the requirements in Transition Manhole, in this section and Part Two, Section 28 (Hydrogen Sulfide (H<sub>2</sub>S) Control) and Part Two, Section 3 (Selection of Pipe Material-Gravity Sewer).



## 25. Grinder Pump, Pressure Sewer System.

### a. General.

- 1) Refer to WSSC Standard Operating Procedure governing authorization of grinder pump/pressure sewer systems. A grinder pump and pressure sewer system is to be considered as an alternative for providing sewer service for a site, only if the site cannot be serviced by conventional gravity systems (including pumping stations).
- 2) Pressure sewer system is defined in this section as an area to be serviced by more than a single grinder pump.

### b. Design Requirements.

- 1) Grinder pumps used in pressure sewer systems for residential areas can only be the ones that have been previously approved or ones that may be subject to approval by the WSSC for systems applications. Determine the type and model of the pump suitable for the system.
- 2) All pump types and models are to be the same in a single pressure sewer system unless otherwise approved by the WSSC.
- 3) Primary design parameters to be considered are the number of pumps under simultaneous operation, flow velocities in pressure sewer piping, and limiting the operating head at a pump. Consider the following guidelines in defining these parameters:

#### a) Number of pumps under simultaneous operation.

- (1) For Semi-positive displacement pump systems, using Environment One (E/1) pumps, the maximum number of simultaneously operating pumps has been statistically defined and referenced in the Environment One Pressure Sewer Design Handbook. Use this information for the design of such systems.
- (2) For Centrifugal pump systems.
  - (a) The maximum number of pumps that may be expected to operate simultaneously has not been consistently developed for centrifugal pump systems. Such systems shall be sized so that the pumps under simultaneous operation shall be able to discharge the peak flow generated by the dwelling units located upstream of any point in the pressure sewer system under consideration.
  - (b) For centrifugal pumps having a nominal discharge rate relatively close to that of an E/1 pump, the maximum number of simultaneously operating pumps developed for E/1 pump systems may be used.

#### b) Flow velocities.

- (1) Size a system for the maximum number of pumps that may be expected to operate under the full development stage, thereby generating the highest flow velocities and pumping head. Also consider in the design system hydraulics during the initial stage when a fewer number



- of pumps are expected to operate and lower velocities may be expected.
- (2) The minimum flow velocity should be approximately three (3) fps under simultaneous pump operating conditions, except for piping servicing one to two dwelling units where a two (2) fps minimum velocity shall be used. A three (3) fps minimum velocity criteria is required for pressure sewer profiles which have multiple high points and low points.
  - (3) The maximum velocity shall be approximately seven (7) fps under simultaneous pump operating conditions.
- c) Operating head at a pump.
- (1) Design an E/1 semi-positive displacement pump at one hundred twenty-five (125) ± feet (maximum) of pumping head, although the manufacturer's pump performance curve may show a maximum operating head of one hundred thirty-eight (138) feet. WSSC recommends maximum pumping head for system design to be ninety (90%) percent of the manufacturer's pump performance curve.
  - (2) Design a centrifugal pump not to operate at above ninety (90%) percent of its shut off head and at or below its cut off point. The shut off head is the head at zero pump discharge; the cut off point is a point on the pump curve where discharge head decreases abruptly with a small incremental flow.
  - (3) Size a pressure sewer system and develop alternative designs such that the above criteria can be met during the full development stage and the initial stage as well.
- 4) Piping system design. With the selected maximum number of grinder pumps in simultaneous operation, design the piping system and submit all calculations, using the following design methods:
- a) For semi-positive displacement pump systems using E/1 pumps, the design methodology is described in detail in the E/1 Design Handbook for Pressure Sewer Systems. Computerized design may be used for complex systems to give better accuracy in hydraulic calculations.
  - b) For centrifugal pump systems, a number of branches should be used to represent the piping layout similar to the design of semi-positive displacement pump systems. The peak flow generated by all dwelling units in a branch shall be estimated. Locations of the pumps shall be designated and computer designs shall be used for analyzing system hydraulics during simultaneous pump operation.
  - c) Pumps located at the most remote part of a system, farthest from the point of discharge to gravity system, and pumps located at the lowest elevations in a system must be considered in pump selection for simultaneous operation.
  - d) Size of pressure sewers, maximum 4-inch pipe diameter and minimum 1-1/4-inch pipe diameter.
  - e) Allowable pipe material, SDR-21 PVC pipe and/or SDR-11 HDPE pipe, see Specifications. PVC pipe is generally installed in open-cut trench and HDPE pipe can be installed in open-cut trench or by horizontal directional drilling.



- f) Use Hazen-Williams (HW) friction coefficient of one hundred forty (140) for calculating headlosses through piping. Consider headlosses through fittings and bends and other minor losses when calculating the total dynamic head.
- g) In computing the static head, base the pump elevation on the developer's proposed elevation at which the grinder pump will be installed.
- h) Centrifugal grinder pumps should not be designed to operate at or below the pump's cut off point. This situation can occur at centrifugal pumps located relatively close to the transition manhole and at pump elevations close to that of the transition manhole, when fewer than the maximum number of pumps is operating simultaneously. These operating scenarios should be analyzed during system design, so as to ensure that the pumps will perform satisfactorily under various operating conditions.
- i) Use sound engineering and hydraulic principles in design and analysis. Consider various scenarios of pipe sizes, system layout, and pump operation to arrive at an optimum design. Use of computer analysis enables checking for minimum and maximum flow velocities and pump discharge head under various operating scenarios.
  - (1) Uphill pumping is preferred in a pressure sewer system where the point of discharge to gravity system is at a higher elevation than the rest of the system, so as to maintain positive pressure throughout the system.
  - (2) Eliminate vertical piping alignment that may be conducive to siphoning at high points or gravity drain/air binding in downhill pumping conditions.
  - (3) Ideally, high points and low points are to be avoided and a continuously rising pressure sewer profile toward the point of gravity discharge is to be designed. Place pressure sewer air vacuum and air release valves at all high points in a system, if the high point cannot be eliminated.
  - (4) PVC and HDPE pipe having the same nominal diameter have different inner diameters. Hydraulic calculations used for sizing the pipe diameters of the system should reflect this. If the option of using PVC and/or HDPE piping is allowed, the nominal pipe diameters called for on the drawings may be different depending on the material. For example, calculations might indicate 1-1/2-inch PVC is hydraulically satisfactory in a particular situation. Calculations may indicate, however, that 1-1/2-inch HDPE, due to its smaller ID, is not hydraulically compatible for the same situation. The use of HDPE as an alternative may therefore require 2-inch HDPE. If the Contractor has the option of using either PVC or HDPE under these circumstances, a note must be placed on the drawings indicating that where the drawings show 1-1/2-inch PVC, 2-inch HDPE installed by horizontal directional drilling may be used as an alternative.
- j) Verify calculations used in sizing the grinder pump system with basement elevations shown on the drawings.
- k) Joints and thrust restraint.



- (1) Lengths of PVC pressure sewer pipe greater than 1-1/4-inch diameter are joined together using push-on gasketed integral bell and spigot joints or bell by bell gasketed couplings. 1-1/4-inch PVC pipe is joined together using solvent weld couplings or integral solvent weld bell and spigot joints. In limited cases, for instance at connections to valves in flushing connection manholes, flanged or threaded joints are necessary, see Standard Details PS/1.2 and PS/1.3. Material and installation requirements for all joints are provided in the Specifications. Thrust restraint for PVC pressure sewer pipe is provided by concrete thrust blocking; see Standard Details PS/1.4, PS/1.41 and PS/1.42.
- (2) HDPE pipe is generally a continuous pipe from a long coil or lengths of pipe and fittings joined by thermal butt-fusion, electrofusion, or by special mechanical couplings. Joints for all HDPE pipe that is to be installed by horizontal directional drilling will be butt-fused. Butt-fusion and electrofusion joints are restrained joints and this should be considered in cases where sufficient lengths of pipe can be harnessed for use in thrust restraint in lieu of using concrete thrust blocking. For information on thrust restraint design using restrained joint pipe, see Part Three, Section 27 (Thrust Restraint Design for Buried Piping). Where sufficient length of restrained joint pipe is not available to restrain a fitting, provide thrust blocking, see Standard Details PS/3.0. Special mechanical couplings and transition fittings are used for connecting HDPE pipe to HDPE pipe or to different pipe materials such as PVC in open-cut installation. Material and installation requirements for these special mechanical couplings and transition fittings are included in the Specifications. Some of the mechanical couplings provide joint restraint. HDPE has a very high coefficient of thermal expansion/contraction. To prevent pullout of the HDPE pipe from an unrestrained joint because of contraction due to change in temperature, a small thrust collar is installed on the HDPE pipe adjacent to the unrestrained joint, see Standard Detail PS/3.1. Where an HDPE pipe end is to be inserted into a mechanical type coupling or joint, a metal insert must be installed inside the end of the HDPE pipe that goes into the joint, see Specifications.
- 5) Locator Stations. It may become necessary in the future to locate the HDPE pipe installed by horizontal directional drilling. The Specifications therefore require the Contractor to pull a copper wire along with the pipe. The wire is terminated at each end of the HDPE in a locator station. Two types of locator stations are specified in the Specifications and shown in the Standard Details. One type is used when the wire is terminated in a manhole, such as used for a flushing, air release and transition manholes, see Standard Detail PS/8.0. At the other end provide a flush-mounted underground station used when a manhole is not available or convenient, see Standard Detail PS/8.1. Refer to and indicate on the drawings, the location(s) and type of the locator stations.

**c. Appurtenances and Structures.**

- 1) Flushing connections. Install approximately every four hundred (400) feet in the system, at dead ends and along downhill sloping piping. There are two (2) types of flushing connections, in-line and terminal.
  - a) For terminal and in-line flushing connections for pressure sewers less than 2-1/2-inch diameter, see Standard Detail PS/1.2.
  - b) For in-line flushing connections for pressure sewers 2-1/2-inch to 4-inch diameter, see Standard Detail PS/1.3.



- 2) Air valves. For the design see requirements under Part Two, Section 27 (Air Valves). For Standard Details, see PS/1.5 and PS/1.5a.
- 3) Transition manhole.
- a) Design the connection between the pressure sewer and the gravity sewer with a transition manhole. Set the top of weir elevation in the transition manhole 1-inch higher than the crown of the pressure sewer. Pressure sewers 4-inch and smaller in diameter; see the Standard Details PS/4.0, PS/4.1 and PS/4.2.
  - b) Design the invert elevations of both the pressure sewer and the gravity sewer at the same elevation.
  - c) Hydrogen Sulfide (H<sub>2</sub>S) corrosion mitigation.
    - (1) Coat the interior of the transition manhole, see Specifications and provide a note on the drawings.
    - (2) Coat the interior of the gravity sewer pipeline if it is other than PVC pipe. Note the distance of the gravity sewer piping requiring interior coating on the drawings. The minimum distance for interior pipe coating is to the next manhole, but the design may require several downstream manholes and pipeline sections to have interior coatings, see Specifications.
- 4) Pressure sewer house connections (PSHC).
- a) For trench details for PSHC, see Standard Detail PS/1.0. Provide a service valve assembly at the end of the PSHC; see Standard Detail PS/1.1.
  - b) Do not design PSHC in a common trench with a water house connection (WHC); see Part Three, Section 3 (Pipeline Crossings and Clearances).

**d. Horizontal and Vertical Alignment.**

- 1) Horizontal alignment, see requirements under Part Two, Section 24 (Force Main Design), except for the following:
  - a) For minimum radius of curvature for PVC and HDPE pressure sewer pipe, see Table "18". Radius of curvature at low points should be maximized.

**TABLE "18"**

Minimum Curve Radius for PVC and HDPE Pressure Sewers

Pipe Size	Minimum Radius
1-1/4-inch to 1-1/2-inch	60 feet
2-inch	70 feet
2-1/2-inch	90 feet
3-inch	100 feet
4-inch	130 feet

- b) Do not design ninety (90°) degree bends in the pipeline alignment.



- c) Design the piping layout to minimize the total piping length.
  - 2) Vertical alignment, see requirements under Part Two, Section 24 (Force Main Design).
  - 3) To install HDPE pipe by horizontal directional drilling construction areas will be required at one end of the operation for layout and fusing pipe lengths to be pulled unless coils are used, and at the other end to set up and operate the drilling/pulling machine and drilling fluid storage tank and waste fluid storage. The amount of area required depends on the specific equipment used. Generally, sufficient area will be available in the normal **easement** and construction strip used in the pipeline design. Verify that adequate space is available in the **easement** and construction strip limits.
- e. Required Analysis for Hydrogen Sulfide (H<sub>2</sub>S) Generation and Release.**
- 1) Generation.
    - a) Design submittal requirements. Perform the analysis for the proposed design as indicated in Part Two, Section 29 (Hydrogen Sulfide (H<sub>2</sub>S) Control) to determine the potential for hydrogen sulfide generation.
    - b) System design. Design the piping layout to minimize the total piping lengths and pipe sizes within the constraints of the hydraulic design criteria, so as to minimize sewage detention time in the system. Avoid downhill pumping conditions with a high point above the transition manholes, which will potentially cause the release and accumulation of hydrogen sulfide gas at the high points.
  - 2) Release. The discharge of sewage from a pressure sewer into a gravity sewer can potentially generate odor and the release of hydrogen sulfide at the transition manhole and in the downstream gravity sewer. Turbulence in the transition manhole should be minimized. Consider the corrosive effects of hydrogen sulfide in the design and selection of gravity sewer pipe material downstream of transition manholes, see the requirements in Transition Manhole, in this section, and under Part Two, Section 28 (Hydrogen Sulfide (H<sub>2</sub>S) Control) and Section 3 (Selection of Pipe Material – Gravity Sewers).
- f. Industrial or Commercial Developments.**
- 1) Except for on-site systems, where each system is designed to service one property, the use of grinder pumps systems for non-residential development is not permitted. For on-site grinder pump systems, it is important to recognize the uncertainties in estimating total system flows, daily flow pattern, and the number and capacity of grinder pumps that may be expected to operate simultaneously.
- g. Abandonment of Existing Pressure Sewer.**
- 1) For PVC PSHC, remove minimum one (1) foot section of PSHC; cap existing PSHC at mainline tee and at end of abandoned PSHC. See Standard Detail PS/6.0.
  - 2) For HDPE PSHC, remove minimum two (2) foot section of PSHC, provide coupling, PVC nipple



and cap on mainline side of abandoned PSHC. Provide cap on end of abandoned PSHC. See Standard Detail PS/6.0.

**h. Connecting to Existing Pressure Sewer.**

- 1) Connect new mainline pressure sewer or PSHC to existing pressure sewer using socket tee, nipples and coupling. See Standard Detail PS/5.0.

**i. Connecting Pressure Sewer House Connection (PSHC) into a Gravity Sewer.**

- 1) Connect PSHC to a clean-out and gravity sewer house connection; see Standard Detail PS/1.6.

**j. Shutdown of Existing Pressure Sewer System.**

- 1) Shutdown requirements are in the Specifications.





## 26. Air Valves.

### a. General.

- 1) Ideally, the vertical alignment of sewage force main(s) and grinder pump pressure sewer systems should have only one high point at the discharge point to the gravity sewer. Air release and air and vacuum valves require frequent maintenance in order for them to function as intended. Consider the cost of maintaining the air valves versus the cost associated with eliminating high points on the profile and constructing the force main, or pressure sewer deeper to accommodate the air release, and air and vacuum valves.

### b. Design Requirements.

- 1) First, consider the cost of constructing the force main or pressure sewer deeper to eliminate the need for air valves.
- 2) Determine the appropriate location and size for all air release, and air and vacuum valves and submit the design computations.
- 3) Sulfide build-up in the force main usually can be prevented by injection of compressed air into the force main at the pumping station. Unfortunately, air cannot always be used because of an irregular profile of the force main. Where air release, and air and vacuum valves will be used, determine the process of controlling sulfide buildup and coordinate with the design of the pumping station.
- 4) On profile, determine the invert of the pipeline using the design depth shown on the details for the air valve vaults and manholes; see the requirements under Part Two, Section 10 (Design of Structures).
- 5) Include coating of the interior of the air valve vault/manhole in the design, see Specifications.

### c. Type and Piping Configuration.

- 1) The type of air release, and air **and** vacuum valves used shall be for sewage application only. The air release and air **and** vacuum valves for sewage applications must be equipped with a back-flushing system. Do not use the type of air release, and air **and** vacuum valves which are for water mains.
- 2) Piping configuration.
  - a) Determine the piping configuration for air release, and air and vacuum valves in vaults or manholes and provide details on the drawings.
  - b) Take into account odor from sulfide buildup and locate the vent piping so as not to discharge odor into the air near homes, schools, churches or businesses. If venting of the air release and air and vacuum valves must be discharged near homes, churches, schools or businesses, provide a deodorizing system **as part of the design**.



**d. Design of Air Vacuum Valves and Air Release Valves.**

- 1) Air vacuum valves and air release valves for force mains and pressure sewers generally serve similar purposes as the valves designed for water pipelines. Attempt to avoid and minimize the use of air vacuum and air release valves in force mains and pressure sewers, because these valves generally require regular maintenance to ensure proper performance. The same principles recommended for sizing and locating air valves on water pipelines may be considered applicable for force mains and pressure sewer applications. However, note the following differences.
  - a) Air valve design.
    - (1) **As a minimum requirement** design pressure sewer system, air/vacuum valves and air release valves at the high point in the piping systems. High flow velocities generated during simultaneous operation of the maximum number of pump, may remove some of the air entrapped in a downwardly sloping pipe. However, an exact criterion for the velocity is lacking. Air valves would be needed if the volume of downwardly sloping pipe from a high point to the next low point is in excess of that which can be pumped out during a continuous pumping interval. Under these situations, air valves would be needed at intermediate points along the downward sloping pipe.
    - (2) Sizing.
      - (a) Since blowoff valves generally are not used for the maintenance of force mains or pressure sewer piping, air vacuum valves need not be sized for line draining through blowoff valves for normal maintenance. Air vacuum valves must be sized for line filling. In case of downhill pumping conditions, vacuum pressure can occur at high points elevated above the transition manhole, when pumps shut down. If vacuum pressure is to be prevented, then air vacuum valves should be sized to break the vacuum. However, downhill pumping conditions should be avoided in force main and pressure sewer systems.
      - (b) Evaluate the possibilities of catastrophic conditions such as column separation due to waterhammer effects, and buckling of force main due to internal vacuum. Large size sewage air vacuum valves may be used to alleviate these negative impacts. Air intake through air vacuum valves must be eventually released through small-orifice air release valves. Waterhammer analysis by computer modeling maybe needed for complex systems.
      - (c) Base the operating pressure to be used for sizing of air release valves for a force main on the HGL, developed for the sewage pumping/force main system, assuming new force main conditions, i.e., lower friction losses and lower HGL elevations.
      - (d) Consider the range of pumping rates (minimum to maximum) with estimated range of air release rate to arrive at optimum valve sizes. If the HGL profile elevations exceed the force main elevations during the minimum flow and accumulation of air or sewer gases is not of concern, air release valves may not be needed.



**27. Sewer **Service (House)** Connections (SHC).****a. Type of Service Connections.**

- 1) Connections for individual residential houses and most townhouses require an individual connection.

**b. Allowable Pipe Material for SHC.**

- 1) See Part Two, Section 3 (Selection of Pipe Material – Gravity Sewers).

**c. Size of SHC.**

- 1) SHCs for residential services are generally 4-inch or 6-inch. Larger sizes (8-inch to 12-inch) may be approved by WSSC if required. Submit justification for approval.

**d. Connection of the SHC to the Mainline Sewer.**

- 1) SHCs can be installed using a tee or saddle on mainline sewers 15-inch diameter and smaller. See Connection Notes on Standard Detail S/6.0.
- 2) For SHCs to mainline sewers larger than 15-inches in diameter, provide a manhole at the connection to the mainline sewer.
  - a) A variance may be given on the mainline sewer size requirement for smaller than 27-inches in diameter, if a justification flow analysis and detailed design are provided for review and approval by WSSC. For connection to a mainline using a drop connection; see Standard Detail S/6.0. For mainline sewer 27-inch and larger, SHCs is not allowed without using a manhole.
- 3) No SHC will be permitted if downstream of transition manhole for force mains larger than 4-inch in diameter, no connections between the transition manhole and the next manhole will be allowed.
  - a) Variance may be given on the location of the SHC, if justification, flow analysis and detailed design are provided for review and approval.
- 4) Type of connection to the mainline sewer.
  - a) For PVC mainline sewers, use PVC tee and PVC pipe for the SHCs for a new proposed mainline sewer. When the mainline sewer is existing use a PVC saddle tee; see Standard Detail S/6.3.
  - b) For DIP mainline sewers, use a mechanical joint (MJ) tee and a transition gasket which makes the MJ compatible to a PVC pipe for the SHC; see Specifications.
  - c) When the mainline sewer is other than PVC and DIP, see Specifications and provide a design accordingly.
  - d) For all SHCs 8-inch and larger connection must be made with a manhole.



- e) A SHC connected to a sewer main with a slope of 1% or less shall have a T-Wye fitting at the main line connection. The T-Wye fitting shall be oriented so that the flow from the SHC is directed into the main line in a downstream direction at the T-Wye fitting.

**e. Connection of the SHC to a Manhole.**

- 1) Single SHC to manhole; see requirements under Part Two, Section 12 (Design of Structures). Drop **Service** Connections (DHC) may be designed when single connections are required, see requirements in this section.
- 2) Multiple SHCs to manhole; to facilitate the maintenance of sewer **Service** connections in areas of high-density multi-family residential development, see the following requirements.
  - a) When two (2) or more SHCs are to be provided at the same location, provide a manhole at the mainline sewer.
  - b) Manhole inside diameters, minimum 48-inch and maximum 60-inch.
  - c) Channelization in the manhole.
    - (1) Channel each SHC with a smooth curved channel through the manhole.
    - (2) Interior angle of intersection of the centerline of the multiple SHCs and the discharge mainline sewer pipe, to be not less than ninety (90°) degrees; see requirements and Sketch "W", under Part Two, Section 17 (Manhole Channel Design).
    - (3) Provide 9-inch minimum between outside diameters of SHCs at the interior manhole wall, see requirements and Sketch "N", under Part Two, Section 14 (Pipe to Manhole Geometry).
    - (4) Type of manhole installations for SHCs.
      - (a) Radial SHC see Standard Detail S/6.4 and the following:
        - [1] Whenever possible, design multiple SHCs in a radial manner.
        - [2] Centerline of the SHCs must be designed to pass through the centerline of the manhole.
        - [3] No more than 5 influent radial connections (incoming SHCs and/or mainline sewers) may be connected to a manhole.
      - (b) Parallel SHC; see Standard Detail S/6.5 and the following:
        - [1] Whenever space and alignment constraints prevents the design of radial multiple SHCs, design the connections in a parallel manner.
        - [2] Connections into a manhole are governed by required channelization, diameter of the manhole and the flow of the mainline sewer. Provide a detail of the manhole channelization for the parallel SHCs on the drawings.



d) Inverts of SHCs at manholes.

(1) For mainline sewers smaller than 15-inch diameter, see Part Two, Section 17 (Manhole Channel Design).

(2) For mainline sewers 15-inch and larger, design the invert of the SHC a minimum of 12-inches above the crown of the mainline sewer.

**f. Horizontal Alignment.**

1) **The Designer should** coordinate with the Applicant to determine the appropriate location, **slope** and size.

a) SHC information required on the drawings: limits of the SHC, from the mainline sewer to the property line or as required in this section and the WSSC permit numbers in the General Notes or below the lot number. These numbers will be provided by WSSC **after reviewing and approving of the application.**

b) Type of lots that can be served with a SHC.

(1) Improved lots.

(a) For existing dwellings or buildings, show the elevation of the lowest level of the dwelling or building, (basement or first floor) on the plans and profiles. If the lowest level cannot be served, a note must be provided on the drawings stating what can be served in the dwelling or building with the proposed **SHC.**

(b) For **new/proposed** dwellings or buildings, show the proposed elevations on the plans and profiles.

(2) Unimproved lots.

(a) Existing lots with no dwellings or buildings.

(b) Proposed or future lots with no plans for any dwellings or building.

2) Horizontal location of the SHC.

a) Improved lots; locate the SHC to readily serve the existing or proposed dwellings or buildings in a cost-effective manner.

b) Unimproved lots; where practical, locate the SHC ten (10) feet downgrade from the center of the property being served and individually serve each dwelling or building. In no case should the SHC be closer than ten (10) feet from the downgrade side of the dwelling or building if the SHC must run to the back side of the dwelling or building. See Sketch "Z".

c) When both a Water **Service** Connection (WHC) and a SHC are to be provided, locate both **service** connections in the same trench when possible, see Standard Detail M/18.0 and Part



Three, Section 3 (Pipeline Crossings and Clearances). Existing dwellings or buildings may have existing water (wells) and sewer (septic tanks) connections on the opposite sides of the dwelling or building; in this case locate the SHC in a cost-effective manner.

d) Limits of SHCs.

(1) For SHC 6 inches and smaller.

(a) When within a **public** roadway right of way, terminate the SHC at the property line; see Standard Detail S/6.2.

(b) When within a WSSC **easement**, terminate the SHC as indicated on Standard Detail S/6.7.

(c) At the end of the SHC, terminate the SHC with a vertical and horizontal connection, as shown on Standard Detail S/6.8. The Plumbing Code requires the end of the SHC to have a vertical connection in accordance with Standard Detail S/6.8.

(2) For SHC's 8 inches and larger the connection at the mainline sewer will only be with a manhole. To provide maintenance access to the service line, one of the options below must be used at the customer end of the service connection:

(a) This option is for a future site utility or minor site utility plan where the service line is of the same diameter and on the same line and grade with the terminus service connection.

[1] At the property line and the terminus of the service connection to the mainline provide a cleanout, see Standard Detail S/5.2. At the time when the site utility or minor site utility connects to the existing service connection, the cleanout at the property line shall remain.

[2] For future site utility or minor site utility plan, that indicates a building shall be placed at the property line, provide a cleanout within five (5) feet of the property line or as approved by WSSC.

[3] To meet legal requirements.

[a] This note shall be placed on the site utility plans: "WSSC shall be granted access on private property to the on-site manhole for maintenance of \_\_\_-inch diameter service connection as allowed per WSSC Plumbing Code".

[4] For Onsite utility or minor site utility plan, provide an on-site manhole accessible to WSSC for maintenance purposes, no further than one hundred fifty (150) feet from the WSSC manhole on the mainline connection.

(b) Provide a WSSC manhole on the plan at the customer end of the service connection. This option is required if the conditions for option "a" cannot be met.

**g. Vertical Alignment.**

1) Minimum Cover over the SHC.



- a) Provide minimum cover of three (3) feet over the SHC.
  - b) For minimum clearance between SHC and WHC, see Part Three, Section 3 (Pipeline Crossings and Clearances).
- 2) Maximum Pipe Depth for Pipe Material, see Part Two, Section 3 (Selection of Pipe Material - Gravity Sewers).
- a) Refer to Part Two, Section 8 (Vertical Alignment (Profiles)) for deep sewer requirements.
- 3) Grade or Slope of the SHC. Provide minimum two (2%) percent grade for the SHC.
- 4) Pipeline Clearances; see Part Three, Section 3 (Pipeline Crossings and Clearances).
- 5) Determining the depth of the SHC at the mainline sewer.
- a) Improved lots, determine the invert of the SHC on the mainline sewer using Formula "J" and Sketch "Z"
  - b) Unimproved lots.
    - (1) In existing areas with existing mainline sewers, the SHC is controlled by the invert elevation of the existing mainline sewer. Insure the SHC can connect to the existing mainline sewer with sufficient slope.
    - (2) For proposed mainline sewer extensions for unimproved lots, the normal depth of the mainline sewer is controlled by the adjacent lots (which have dwellings or building) and in general, is not to exceed ten (10) feet. For unimproved commercial areas, the normal depth of the mainline sewer is not to exceed twelve (12) feet.
- c) Drop **Service** Connections (DHC).
- (1) When the depth of the SHC exceeds the twelve (12) feet of cover at the mainline sewer and the minimum elevation of the SHC as calculated using Formula "J" states that the mainline sewer can be at depth of eight (8) feet below the centerline elevation of the road, provide a DHC as follows:
    - (a) DHC to the mainline sewer, Standard Detail S/6.0. Provide the location (station along the mainline sewer) and the invert elevation of the upper vertical 1/8 bend; see Standard Detail S/6.0. Minimum depth of cover required is eight (8) feet measured from the centerline elevation of the roadway or finished grade at the property line.
    - (b) DHC at manholes, Standard Detail S/6.1. Provide the location of the connection at the manhole and the top elevation (invert of the SHC at the property line). Minimum depth of cover required is eight (8) feet measured from the centerline elevation of the roadway finished grade at the property line.
- 6) **Maximum depth of SHC.**



- a) For mainline sewer **20 to 24 feet deep**, connect SHC with a manhole **and not directly to the mainline sewer pipe**.
- b) For mainline sewer **over 24 feet deep**, the SHC should be relocated out of deep areas when possible. When approved by WSSC, **connect SHC with a manhole and not directly to the mainline sewer pipe**.

### FORMULA "J"

$(C - d - h - ID) =$  minimum elevation at the mainline sewer

Where:

- C = elevation of the cellar of the dwelling/building (use FF for first floor)  
 h = distance from the furthest point of the dwelling/building to the mainline sewer multiplied by two (2%) percent, (which is the required **service connection slope**)  
 d = standard dimension for determining the minimum depth requirement under the cellar floor (slab) for clearing the dwelling or building foundation;  
 ID = Inside Diameter of the SHC. (Typically 4-inch or 6-inch diameter)

#### Example (Proposed):

Proposed Cellar elevation of the house to be served is 100.00 and the SHC is 4-inch diameter. Distance using Sketch "Z" (see following page) from Design Point 'a' at the house to Design Point 'b' at the mainline sewer is 75 feet.

House is located in a proposed development and the house is proposed.

$$\begin{aligned} \text{minimum invert elevation @ mainline sewer} &= C - d - h - ID \\ &= 100.00 - 2' - (75' \times 0.02) - 0.33' \\ &= 100.00 - 2' - 1.5' - 0.33' \\ \text{minimum invert elevation @ mainline sewer} &= 96.17 \end{aligned}$$

If the mainline sewer is 8-inch, then the invert of the mainline has to be at 96.00 or lower.

$$\begin{aligned} 96.17 - 0.17' &= 96.00 && 0.17' \text{ is one-half the difference between 8" and 4"} \\ 8" &= 0.67' && 4" = 0.33' && (0.67' - 0.33') \div 2 = 0.17' \end{aligned}$$

#### Example (Existing):

Existing Cellar elevation of the house to be served is 100.00 and the SHC is 4-inch diameter. Distance using Sketch "Z" (see following page) from Design Point 'a' at the house to design Point 'b' at the mainline sewer is 75 feet.

House is located in an existing development and the house is existing.

$$\begin{aligned} \text{minimum elevation @ mainline sewer} &= C - d - h - ID \\ &= 100.00 - 3' - (75' \times 0.02) - 0.33' \\ &= 100.00 - 3' - 1.5' - 0.33' \\ \text{minimum elevation @ mainline sewer} &= 95.17 \end{aligned}$$

If the mainline sewer is 8-inch, then the invert of the mainline has to be at 95.00 or lower.

$$\begin{aligned} 95.17 - 0.17' &= 95.00 && 0.17' \text{ is one-half the difference between 8" and 4"} \\ 8" &= 0.67' && 4" = 0.33' && (0.67' - 0.33') \div 2 = 0.17' \end{aligned}$$





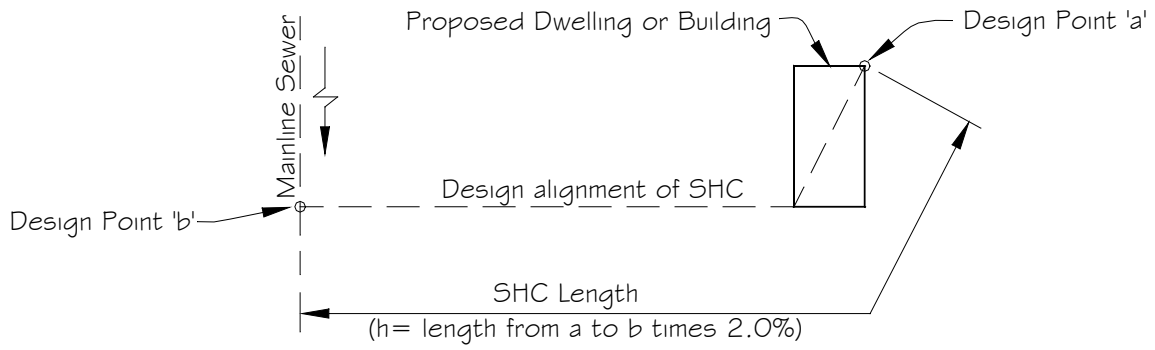

PLAN - Design of the rate of run from Proposed Dwelling or Building to Mainline Sewer

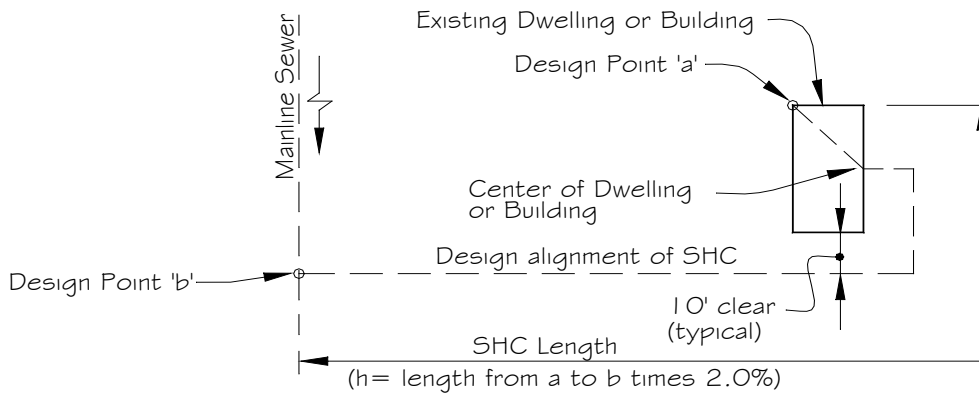

PLAN - Design of the rate of run from Existing Dwelling or Building to Mainline Sewer

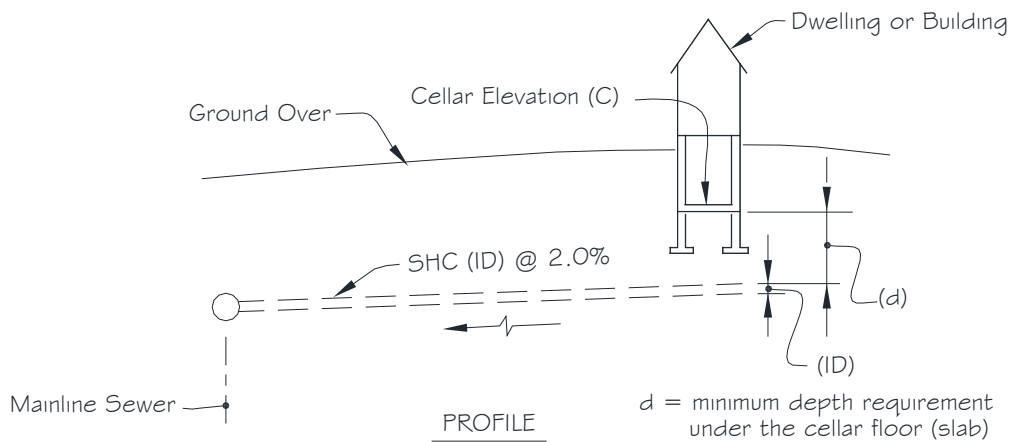

$d$  = minimum depth requirement under the cellar floor (slab)  
 use three (3) feet for existing and two (2) feet for proposed dwelling/building

SKETCH "Z"

Determining SHC Invert Elevation at Mainline Sewer



## 28. Hydrogen Sulfide (H<sub>2</sub>S) Control.

### a. General.

- 1) Consider the potential for hydrogen sulfide generation and release into proposed and existing sewers as result of the proposed design. Design the sewer systems to minimize the generation and release of hydrogen sulfide as indicated in this section.
- 2) Evaluate the following sewer pipelines for hydrogen sulfide generation and release:
  - a) H<sub>2</sub>S generation. All gravity sewers 27-inch and larger must be evaluated and designed to minimize hydrogen sulfide (H<sub>2</sub>S) generation, see requirements in this section.
  - b) H<sub>2</sub>S release. The release of hydrogen sulfide which is most prevalent downstream of force mains and small diameter pressure sewers, occurs in all sizes of gravity sewers at transition manholes and in a portion of the piping and manholes downstream of the transition manhole. Therefore, hydrogen sulfide generation concentrations in small diameter pressure sewer systems and all force mains must be evaluated at the transition manhole as indicated below.
- 3) Perform analyses and prepare calculations according to the guidelines in this section and submit calculations and design to the WSSC.

### b. Analysis for Hydrogen Sulfide Generation.

- 1) Criteria for H<sub>2</sub>S generation forecasting in the design of gravity sewers 27-inch and larger.
  - a) Chart "B", curves A/B provides approximate qualitative guidelines to indicate the likelihood of H<sub>2</sub>S generation.
  - b) If the design of the sanitary sewer falls in the field above curve A, it is unlikely that there will be any significant sulfide buildup.
  - c) If the design falls below curve B, the development of sulfide is likely, see Selection of Pipe and Structure Material, in this section.
- 2) Grinder pump systems and force mains.
  - a) Use Pomeroy's Equation for predicting hydrogen sulfide generation in 4-inch and smaller diameter pressure sewers (grinder pump systems) and all force mains.
  - b) If hydrogen sulfide generation is predicted in these systems, include in the design the necessary provisions to either neutralize the H<sub>2</sub>S or protect the downstream piping and structures from sulfide attack. Minimum sulfide concentrations (S<sub>2</sub>) of 1 mg/l can cause problems in sewers.
- 3) After performing the analysis, request guidance from WSSC on the necessary provisions in the design to protect the sewer from H<sub>2</sub>S attack, see Selection of Pipe and Structure Material, in this section.



**POMEROY'S EQUATION**

$$S_2 = S_1 + [M \times t \times \text{EBOD} \times ((4/d) + 1.57)]$$

Where:

$S_2$  = sulfide concentration at the transition manhole, mg/l

$S_1$  = sulfide concentration at the pump station wet well, mg/l;

for pump station influent sewers 24" and smaller,  $S_1 = 0$ ;

for pump station influent sewers 27" and larger, consult with WSSC for determining  $S_1$

M = empirical coefficient;

for force mains larger than 6", M = 0.001;

for pressure sewers and force mains 6" and smaller, M = 0.0003

t = detention time, hours

EBOD =  $\text{BOD}_5 \times 1.07^{(T-20)}$ , (assume EBOD = 300 mg/l maximum during summer months)

d = pipe diameter in meters

**NOTE:** The use of the A/B curves is restricted to sanitary sewers with flow depths not exceeding two-thirds of the pipe inside diameter. Use the initial six-hour average high flow, which occurs during the hottest three months of the year. Do not use the ultimate flow, when using the A/B curve to predict H<sub>2</sub>S generation. (Assume the initial high flow equals 1.5 times the initial annual average daily flow)

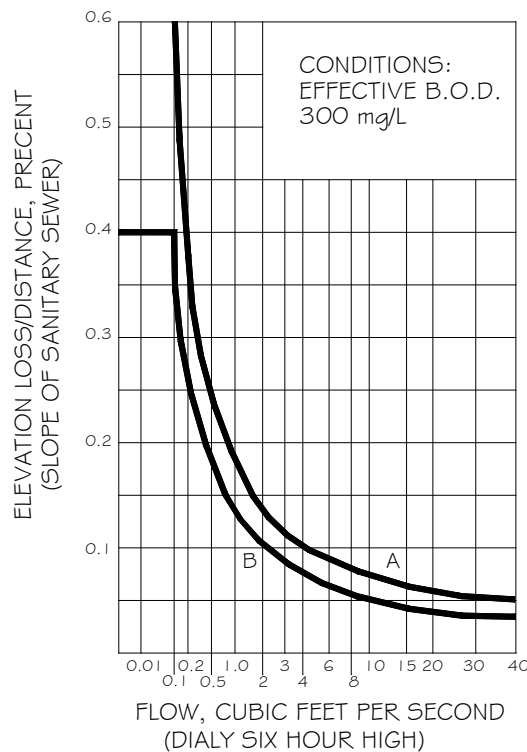

**CHART "B"**  
Flow-Slope Relationship  
as a Guide to  
Sulfide Forecasting,  
Effective BOD of 300 mg/L

Chart "B" is a copied from Figure 4-5, Flow-slope relationship as a guide to sulfide forecasting, Effective BOD of 300 mg/L (From: the ASCE, Manual and Reports on Engineering Practice, No. 60, Gravity Sanitary Sewer Design and Construction, Chapter 4, Sulfide Generation, Corrosion, and Corrosion Protection in Sanitary Sewers.)



**c. Selection of Pipe and Structure Material.**

- 1) Give consideration to the selection of the sewer pipeline and structure materials when substantial hydrogen sulfide generation has been predicted and cannot be prevented through design changes in pipe size, pipe slope, etc. Design susceptible sewer pipelines and structures to resist attack from sulfuric acid, which is a product of hydrogen sulfide concentrations. Protect pipelines and structures from this condition, either by the use of H<sub>2</sub>S corrosion resistant pipe materials such as PVC and/or linings/coatings for the sewer pipe and associated manholes/structures, manhole steps, etc.

**d. Additional Design Considerations to Mitigate Hydrogen Sulfide Generation and Release.**

- 1) For additional design considerations to mitigate H<sub>2</sub>S generation and release, see the following sections in Part Two; Section 3 (Selection of Pipe Material - Gravity Sewer), Section 8 (Vertical Alignment - Profiles), Section 15 (Pipe Slope and Manhole Distance), Section 16 (Manhole Drop Connections), Section 24 (Force Main Design), Section 25 (Grinder Pump, Pressure Sewer System) and Appendix C.





# PART THREE

## Common Design Guidelines

**PART THREE**

**COMMON DESIGN GUIDELINES**

**General.**

Part Three of the Pipeline Design Manual covers the minimum standard design criteria which are common to the design of both water and sewer pipelines, and is to be followed when preparing the design of water and sewer pipelines and appurtenances within the Washington Suburban Sanitary District (WSSD). This part of the manual is to be used in conjunction with Part One, Water Design Guidelines and Part Two, Sewer Design Guidelines. Although this manual is intended as a guideline, it shall remain the Engineer's/Designer's responsibility to review and verify the applicability of all material presented herein as it pertains to the specific project under design.



## TABLE OF CONTENTS

### PART THREE - COMMON DESIGN GUIDELINES

<b>1. Survey and Stakeout Information.</b>	<b>C - 1.1</b>
a. General.	C - 1.1
b. Survey Controls.	C - 1.1
c. Stakeout Controls.	C - 1.1
<b>2. Easements and Construction Strips.</b>	<b>C - 2.1</b>
a. General.	C - 2.1
b. Existing Pipeline Width Requirements.	C - 2.1
c. Proposed Pipeline Width Requirements.	C - 2.2
d. Location of Pipelines Within Rights of Way and Construction Strips.	C - 2.3
e. Easement for Water Pipeline Appurtenances.	C - 2.4
f. Construction Strips.	C - 2.4
g. Access Points Along the Easement.	C - 2.5
h. Property of the Maryland National Capital Park and Planning Commission (MNCPPC).	C - 2.5
i. Potomac Electric Power Company (PEPCO).	C - 2.5
<b>3. Pipeline Crossings and Clearances.</b>	<b>C - 3.1</b>
a. General.	C - 3.1
b. Vertical Clearances for Pipeline or Utility Crossings.	C - 3.1
c. Working within Maryland Transit Administration (MTA)) Rail Lines.	C - 3.2
d. Horizontal Separation With Other Utilities/Structures.	C - 3.4
e. Crossing under Existing Pipelines and Utilities.	C - 3.6
f. Vertical Separation For Gravity and Pressure Sewer Pipelines Crossing Water Pipelines.	C - 3.7
g. Horizontal Separation Between SHC and WHC.	C - 3.7
h. Alternatives - When Water and Sewer Clearances Cannot Be Met.	C - 3.7
i. Working in the Vicinity of Existing 30-inch and Larger Water Mains.	C - 3.9
j. Requirements for Construction across on in Vicinity of City of Rockville's Existing 24-inch Water Transmission Main	C - 3.10
<b>4. Buoyancy of Pipelines.</b>	<b>C - 4.1</b>
a. General.	C - 4.1
b. Design Procedures.	C - 4.1
c. Preventive Procedures.	C - 4.5
d. Example.	C - 4.5
e. Reference.	C - 4.7
<b>5. Pipeline Abandonment.</b>	<b>C - 5.1</b>
a. General.	C - 5.1
b. Requirements.	C - 5.1
<b>6. Modifications to Specifications and Standard Details.</b>	<b>C - 6.1</b>
a. General.	C - 6.1
b. Modified Standard Details.	C - 6.1
c. Special Provisions to Specifications.	C - 6.1



<b>7. Erosion Checks.</b>	<b>C - 7.1</b>
a. Requirements.	C - 7.1
b. Design.	C - 7.1
<b>8. Erosion and Sediment Control and Tree Protection.</b>	<b>C - 8.1</b>
a. General.	C - 8.1
b. Utility Erosion and Sediment Control Plan Approval and Permit Acquisition for Utility Construction.	C - 8.1
c. Design Requirements.	C - 8.4
d. Sediment Control Devices.	C - 8.5
e. Tree Protection.	C - 8.12
<b>9. Pipeline Stream Crossings.</b>	<b>C - 9.1</b>
a. General.	C - 9.1
b. Selection of Crossing Alignment.	C - 9.1
c. Data Collection.	C - 9.2
d. Estimate of Stream Design Flow.	C - 9.2
e. Determination of Cover Depth.	C - 9.3
f. Post Construction Stabilization of Channel Banks.	C - 9.4
g. Special Considerations.	C - 9.5
h. Calculations for Existing Mean Annual Flood and Existing Bankful Flood Discharge.	C - 9.6
i. Calculations for the Required Cover Depth for Protection Against Channel Bed Erosion.	C - 9.6
<b>10. Bridge Crossings.</b>	<b>C - 10.1</b>
a. Conceptual Design.	C - 10.1
b. General.	C - 10.1
c. Predesign Submittals and Approvals.	C - 10.1
d. Predesign Bridge Crossing Meeting.	C - 10.2
e. Allowable Pipeline Material.	C - 10.2
f. Fittings on Bridge Structures.	C - 10.4
g. Joint Deflections on Bridge Structures.	C - 10.4
h. Pipeline Coating Requirements.	C - 10.4
i. Pipeline Identification.	C - 10.4
j. Design of Pipelines in Casing Pipes.	C - 10.5
k. Isolation Valves.	C - 10.5
l. Location of the Pipeline on the Bridge Structure.	C - 10.5
m. Buried Pipelines Entering the Bridge Structure.	C - 10.6
n. Pipe Thrust on the Bridge Structure.	C - 10.7
o. Pipe Load on the Bridge Structure.	C - 10.7
p. Attaching the Pipeline to the Bridge Structure.	C - 10.7
q. Design of the Pipeline to Prevent Freezing.	C - 10.8
r. Design of the Pipeline for Expansion and Contraction.	C - 10.9
s. Design of Dewatering and Air Release Appurtenances on Bridge Structures.	C - 10.10
t. Pipelines to be Abandoned on the Bridge Structure.	C - 10.10
u. References.	C - 10.11
<b>11. Loading Analysis of Existing Pipelines.</b>	<b>C - 11.1</b>
a. General.	C - 11.1
b. Abbreviations.	C - 11.1
c. Ductile Iron Pipe (DIP) Water Pipelines.	C - 11.1





d. Cast Iron Pipe (CIP) Water Pipelines.	C - 11.2
e. Polyvinyl Chloride (PVC) Pipe AWWA C-900 DR 14 Water Pipe	C -11.4
f. Prestressed Concrete Cylinder Pipe (PCCP) Water Pipelines.	C - 11.4
g. Asbestos Cement Pipe (ACP) Water Pipelines.	C - 11.7
h. Polyvinyl Chloride (PVC) Pipe Sewer Pipelines.	C - 11.7
i. Polyvinyl Chloride (PVC) Pipe AWWA C-900 DR 14 Water Pipe	C -11.7
j. Ductile Iron Pipe (DIP) Sewer Pipelines.	C - 11.8
k. Vitrified Clay Pipe Extra Strength (VCPX), Concrete Sewer Pipe Extra Strength (CSPX) and Asbestos Cement Pipe (ACP) Sewer Pipelines.	C - 11.8
l. Reinforced Concrete Pipe (RCP), Reinforced Concrete Sewer Pipe (RCSP), Reinforced Concrete Culvert Pipe (RCCP), Reinforced Concrete Culvert Pipe Extra Strength (RCCPX) Sewer Pipelines.	C - 11.11
m. Ductile Iron Pipe (DIP) Force Mains.	C - 11.13
n. Cast Iron Pipe (CIP) Force Mains.	C - 11.14
o. Polyvinyl Chloride (PVC) Small Diameter Pressure Sewers.	C - 11.14
<b>12. Related Design and Analysis.</b>	<b>C - 12.1</b>
a. Methods to Increase Strength of Pipe Due to a Change in Loading Conditions.	C - 12.1
b. Field Investigations to Verify Assumptions Made in Analysis.	C - 12.2
c. Necessity for Pipeline Relocations.	C - 12.3
d. Methods to Protect Pipelines During Construction.	C - 12.4
e. Submittal Information Required for the Proposed Grading over WSSC Pipelines.	C - 12.5
<b>13. Concrete Encasement, Arches and Cradles.</b>	<b>C - 13.1</b>
a. Concrete Encasement.	C - 13.1
b. Concrete Arches.	C - 13.1
c. Concrete Cradles.	C - 13.2
<b>14. Anchoring Pipes on Steep Slopes.</b>	<b>C - 14.1</b>
a. General.	C - 14.1
b. Design Requirements.	C - 14.1
<b>15. Pipe Joint Clearances within Structures.</b>	<b>C - 15.1</b>
a. General.	C - 15.1
b. Minimum Distances for Flanged Joints.	C - 15.1
c. Minimum Distances for Mechanical, Push-on and Plain End Joints.	C - 15.1
<b>16. Design of Pipeline Structures.</b>	<b>C - 16.1</b>
a. General.	C - 16.1
b. Abbreviations for References.	C - 16.1
c. Design Loads for Pipeline Structures.	C - 16.1
d. Design Criteria (Codes and Standards) for Pipeline Structures.	C - 16.2
e. Concrete Structures.	C - 16.2
f. Miscellaneous Metals.	C - 16.5
<b>17. Evaluation of Existing Pipeline Structures.</b>	<b>C - 17.1</b>
a. General.	C - 17.1
b. Analysis.	C - 17.1
c. Procedure.	C - 17.1



d. Guidelines and References for Evaluating Existing Structures.	C - 17.1
e. Evaluation of Structural Components.	C - 17.3
<b>18. Temporary Construction Support Criteria.</b>	<b>C - 18.1</b>
a. General.	C - 18.1
b. Guidelines.	C - 18.1
<b>19. Geotechnical Considerations for Pipeline Alignments.</b>	<b>C - 19.1</b>
a. General.	C - 19.1
b. Geology of the Site.	C - 19.1
c. Soil Conditions.	C - 19.1
d. Groundwater Conditions.	C - 19.1
e. Crossing of Highways and Railroads Requiring Tunneling.	C - 19.1
f. Crossing of Environmentally Sensitive Areas.	C - 19.1
g. Crossing Contaminated Areas.	C - 19.2
h. Proximity to Existing Structures and Other Utilities.	C - 19.2
i. Need for Deep Cuts or Excessive Fills.	C - 19.2
j. Need for Special Bedding and/or Backfill.	C - 19.2
k. Need for Blocking and/or Restrained Joints.	C - 19.3
l. Crossing and working within Marlboro Clay areas	C - 19.3
<b>20. Geotechnical and Corrosion Submittals.</b>	<b>C - 20.1</b>
a. General.	C - 20.1
b. First Submittal	C - 20.1
c. Second Submittal.	C - 20.1
d. Electronic data submittals	C - 20.2
<b>21. Lateral Support for Buried Pipelines.</b>	<b>C - 21.1</b>
a. General.	C - 21.1
b. Guidelines.	C - 21.1
<b>22. Slope Stability.</b>	<b>C - 22.1</b>
a. General.	C - 22.1
b. Slope Failures.	C - 22.1
c. Soil cut and fill slope design considerations	C - 22.2
d. Selection of Pipeline Alignment.	C - 22.3
e. Method of Stabilization.	C - 22.3
f. References.	C - 22.3
<b>23. Pipeline Design in Wetlands.</b>	<b>C - 23.1</b>
a. General.	C - 23.1
b. Guidelines.	C - 23.1
c. Standard Wetlands Notes.	C - 23.1
<b>24. Design Guidelines for Pipelines Crossing or Located in the Vicinity of Contaminated Areas</b>	<b>C - 24.1</b>
a. General.	C - 24.1
b. Contaminant Type and Distribution.	C - 24.4



c.	Trench Excavation Considerations.	C - 24.6
d.	Pipeline Material Considerations.	C - 24.7
e.	Trench Backfill Considerations.	C - 24.9
f.	Regulatory Considerations.	C - 24.10
<b>25.</b>	<b>Tunnels.</b>	<b>C - 25.1</b>
a.	General.	C - 25.1
b.	Conditions and Requirements for Tunnels.	C - 25.1
<b>26.</b>	<b>Tunnel Design Criteria.</b>	<b>C - 26.1</b>
a.	General.	C - 26.1
b.	Tunnel Use.	C - 26.1
c.	Tunnel Casing Length.	C - 26.1
d.	Tunnel Casing Diameter.	C - 26.3
e.	Minimum Soil Cover.	C - 26.3
f.	Soil Ground Tunneling Methods.	C - 26.3
g.	Clearances with Surrounding Installations.	C - 26.3
h.	Tunnel Soil Investigation Submittals and Tunnel Geotechnical Report.	C - 26.5
i.	Soil Parameters.	C - 26.6
j.	Behavior of Ground at Heading.	C - 26.6
k.	Surface Settlement Estimation.	C - 26.11
l.	Tunnel Design.	C - 26.12
m.	Access Shaft and Jacking Pit.	C - 26.16
n.	Dewatering.	C - 26.16
o.	Casing Seal, Permanent/Temporary Bulkhead or Tunnel Access Manhole.	C - 26.17
p.	Carrier Pipe Tie-Downs.	C - 26.18
q.	Ground Movement Monitoring.	C - 26.18
r.	Codes	C - 26.19
s.	References.	C - 26.19
<b>27.</b>	<b>Thrust Restraint Design for Buried Piping.</b>	<b>C - 27.1</b>
a.	General.	C - 27.1
b.	General Requirements for Concrete Thrust Blocks.	C - 27.1
c.	Standard Design for Concrete Thrust Blocks.	C - 27.1
d.	Special Design for Concrete Thrust Blocks.	C - 27.2
e.	Design Example: Horizontal Bend Concrete Thrust Blocks.	C - 27.4
f.	Design Example: Upper Vertical Bend Concrete Thrust Blocks.	C - 27.9
g.	Design Example: Lower Vertical Bend Concrete Thrust Blocks.	C - 27.11
h.	Restrained Pipe Joints.	C - 27.12
i.	Design Example for Determining Requiring Length of Restrained Pipe.	C - 27.15
j.	Thrust Blocks for Quick Connections to Existing Pipelines.	C - 27.17
k.	Welded-on Thrust Ring Blocks for New Pipe.	C - 27.17
l.	Restraining Reducers.	C - 27.19
m.	Restraining Valves.	C - 27.23
n.	Unbalanced Thrust at Connections to Existing Water Pipelines.	C - 27.25
o.	Passive Soil Pressure for Concrete Thrust Blocks.	C - 27.27
p.	Blocking Notes on the Drawings.	C - 27.28
<b>28.</b>	<b>Corrosion Control.</b>	<b>C - 28.1</b>
a.	Abbreviation.	C - 28.1
b.	General.	C - 28.1
c.	Corrosion Design Procedure and Submittal Requirements.	C - 28.2



d. Soil Condition Analysis.	C - 28.3
e. Stray Current Analysis.	C - 28.6
f. Existing Pipe Analysis.	C - 28.7
g. Corrosion Survey Checklist.	C - 28.9
h. FORM "B" Corrosion Documentation.	C - 28.10

## FIGURES

<b>Figure "B"</b>	Backfill Volumes Over Pipe.	C - 4.3
<b>Figure "C"</b>	Trench Bedding for Circular Concrete, Clay and Asbestos Cement Pipe.	C - 11.15
<b>Figure "D"</b>	Anticipated Ground Behavior Based on $D_{10}$ Size.	C - 26.10
<b>Figure "E"</b>	Compressed Air Pressure for Tunneling in Silty Sands.	C - 26.10
<b>Figure "F"</b>	Error Function Representation of Settlement Trough Above Tunnel.	C - 26.12
<b>Figure "G"</b>	Relationship Between Width of Settlement Trough and Depth of Tunnel.	C - 26.12
<b>Figure "H"</b>	Coefficient of Pressure for Tunnel Design.	C - 26.14
<b>Figure "I"</b>	Dimensionless Anchor Resistance Ratio, $A^S/A^O$ .	C - 27.7
<b>Figure "J"</b>	Earth Pressure Coefficient for Normal Earth Pressure in Front of Block.	C - 27.8
<b>Figure "K"</b>	Dimensionless Anchor Resistance Ratio, $(\ell^c - 1) / (H + h)$ .	C - 27.8

## FORMS

<b>Form "A"</b>	Thrust Restraint Schedule.	C-20-Form A-1
<b>Form "B"</b>	Corrosion Documentation.	C-28.11

## SKETCHES

<b>Sketch "AA"</b>	Clearances - Pipeline Crossing.	C -3.2
<b>Sketch "UU"</b>	MTA Light Rail Zone of Influence Rails	C -3.2
<b>Sketch "VV"</b>	Profile of Tunnel Crossing MTA Rails	C -3.2
<b>Sketch "WW"</b>	Proposed Water and Sewer Mains and Connections Adjacent to Bio-Swale or Rain Garden Device.	C - 3.5
<b>Sketch "YY"</b>	Proposed Water and Sewer Mains and Connections Bio-Swale or Rain Garden – No Break.	C – 3.6
<b>Sketch "XX"</b>	Proposed Water and Sewer Mains and Connections Bio-Swale or Rain Garden – At Break.	C – 3.7
<b>Sketch "ZZ"</b>	Existing Water and Sewer Mains and Connections Adjacent to Proposed ESD with Structural Vertical Wall. .	C – 3.8
<b>Sketch "WW1"</b>	Existing Water and Sewer Mains and Connections Proposed Bio-Swale or Rain Garden Device.	C – 3.9
<b>Sketch "YY1"</b>	Existing Water and Sewer Mains and Connections Adjacent to Proposed Bio-Swale or Rain Garden – No Break.	C – 3.6
<b>Sketch "BB"</b>	Trench Erosion Checks for Pipelines.	C - 7.1
<b>Sketch "CC"</b>	Concrete Anchors for Pipelines.	C - 14.1
<b>Sketch "DD"</b>	Location of Flanged Joint at Structures.	C - 15.1
<b>Sketch "EE"</b>	Location of Mechanical, Push-on or Plain End Joints at Structures.	C - 15.1



<b>Sketch "VV"</b>	<b>Profile of Tunnel Crossing MTA Rails</b>	<b>C - 26.2</b>
<b>Sketch "FF"</b>	Profile of Tunnel Crossing MSHA Controlled Access and Interstate Highway.	C - 26.3
<b>Sketch "GG"</b>	Profile of Tunnel Crossing MSHA Highway other than Controlled Access and Interstate Highway.	C - 26.3
<b>Sketch "II"</b>	Example of Concrete Thrust Block for Horizontal Bend.	C - 27.5
<b>Sketch "JJ"</b>	Example of Concrete Thrust Block for Upper Vertical Bend.	C - 27.10
<b>Sketch "KK"</b>	Example of Concrete Thrust Block for Lower Vertical Bend.	C - 27.11
<b>Sketch "LL"</b>	Example of Restrained Joint System.	C - 27.16
<b>Sketch "LL1"</b>	<b>Example of Restrained Joint Systems</b>	<b>C - 27.16</b>
<b>Sketch "PPA"</b>	<b>Example of Restrained Joint Systems</b>	<b>C - 27.21</b>
<b>Sketch "MM"</b>	Thrust Block Cast Directly Around Reducer.	C - 27.22
<b>Sketch "NN"</b>	Welded-on Thrust Ring Block to Restrain Reducer (Large End).	C - 27.22
<b>Sketch "OO"</b>	Welded-on Thrust Ring Block to Restrain Reducer (Small End).	C - 27.23
<b>Sketch "PP"</b>	Blocking A Reducer When Reducing Down Into A Tee.	C - 27.23
<b>Sketch "QQ"</b>	Schematic Examples of Thrust Vaults For 16" and Larger Valves.	C - 27.24
<b>Sketch "RR"</b>	Valves 16" and Larger Restrained with Thrust Collar Blocking.	C - 27.24
<b>Sketch "SS"</b>	Connection PCCP to DIP Showing Unbalanced Thrusts.	C - 27.26
<b>Sketch "TT"</b>	Zone of Influence for Passive Soil Resistance.	C - 27.28

## TABLES

<b>Table "20"</b>	<b>Easement</b> and Construction Strip Minimum Width Requirements for Water Pipelines.	C - 2.2
<b>Table "21"</b>	<b>Easement</b> and Construction Strip Minimum Width Requirements for Sewer Pipelines.	C - 2.2
<b>Table "22"</b>	Manning's Roughness Coefficient for Stream Channel Material.	C - 9.6
<b>Table "23"</b>	Permissible Velocities for Stream Channel Material.	C - 9.8
<b>Table "24"</b>	Coefficients of Thermal Expansion.	C - 10.9
<b>Table "25"</b>	Empirical Correlation of Soils.	C - 26.9
<b>Table "26"</b>	Value of $P_1$ .	C - 26.4
<b>Table "27"</b>	<b>Restrain Joint Pipe Length</b>	<b>C - 27.14</b>
<b>Table "28"</b>	<b>Restrain Joint Pipe for Reducers.</b>	<b>C - 27.21</b>
<b>Table "29"</b>	DIP and PCCP Sealing Diameters.	C - 27.25
<b>Table "30"</b>	Soil Condition Analysis.	C - 28.4
<b>Table "31"</b>	Overall Corrosivity Rating.	C - 28.4
<b>Table "32"</b>	Stray Current Analysis.	C - 28.7

## CHARTS

<b>Chart "C"</b>	<b>Corrosion Control Decision Tree for new Ductile Iron Pipelines</b>	<b>C - 28.5</b>
<b>Chart "D"</b>	<b>Corrosion Control Decision Tree Connecting to Existing Ductile Iron Pipes</b>	<b>C - 28.8</b>



## 1. Survey and Stakeout Information.

### a. General.

- 1) Stakeout controls; provide the necessary stakeout controls on the drawings for setting the alignment to construct the pipeline(s). For SEP and DRP projects, stakeout controls are not required to be shown on design plans.
- 2) Survey controls, see Appendix "D" (WSSC Survey and Easement Criteria), for WSSC standards and requirements.

### b. Survey Controls.

- 1) Survey controls to be shown on the drawings. Depending on the type of pipeline construction, different survey controls may be required. The following guidelines indicate the type of information to be shown on the drawings. For additional requirements and information, see Appendix "D" (WSSC Survey and Right of Way Criteria).
  - a) For SEP and DRP projects, provide a note in the General Notes, stating that the applicant will be required to provide all controls and stakeout associated with the construction.
  - b) Existing subdivision, outfall, etc. provide survey and stakeout information on the drawings.

### c. Stakeout Controls

- 1) Provide survey information, when required. For additional requirements and information, see Appendix "D" (Survey and Easement Criteria).
  - a) Horizontal stakeout control (traverse lines), show the traverse station numbers, azimuths, distances between stations and sketches of the traverse references.
  - b) Vertical stakeout control, show the described turning points and bench marks with the index number, elevation and description. Provide at least three (3) bench marks per contract plan set, including at least one (1) bench mark per plan sheet.
- 2) Alignment stakeout information to be shown on the drawing(s).
  - a) Water pipelines smaller than 24-inch diameter.
    - (1) Show the final ties to all existing pipelines at the cap or plug. If no ties are available, note that on the plans as NTA (No Ties Available).
    - (2) Pipelines in horizontal curves. Show the radius of the curve and the location of the tangent points of the curve (PC, PI and PT). Exceptions, if the pipeline is 12-inch and smaller, and is running parallel to or meandering along a roadway.
    - (3) Provide stakeout ties for pipelines and appurtenances as follows:
      - (a) For pipelines larger than 12-inch and smaller than 24-inch, provide stakeout from the



traverse stations.

(b) For pipelines 12-inch and smaller, provide stakeout from physical features, if available. If not available, provide from the traverse stations.

(c) If the pipeline is located within a proposed subdivision or development, **provide coordinates as stated in Appendix D.**

b) Water pipelines 24-inch and larger in diameter.

(1) Show the final ties to all existing pipelines at the cap or plug. If no ties are available, note that on the plans as NTA.

(2) Provide stakeout ties for pipeline fittings and appurtenances from the traverse stations, which includes; tangent points (PC, PT) and points of intersection (PI) for all horizontal curves. For horizontal curves, show the delta, radius, tangent, length or arc of the curve, and pipeline stations and location of tangent points (PC, PT).

c) Sewer pipelines smaller than 24-inch in diameter, provide stakeout ties from the traverse stations for manholes. If the manholes and pipelines are located within a proposed subdivision or development, provide stakeout ties from property corners, proposed road stations, etc.

d) Sewer pipelines larger than 24-inch in diameter, provide stakeout ties from the traverse stations for manholes, and tangent points (PC, PT) and point of intersection (PI) for all horizontal curves.

e) Force mains and pressure sewers, provide stakeout in accordance with the requirements for water pipelines.



## 2. Easements and Construction Strips.

### a. General.

- 1) When a water or sewer pipeline(s) extends into property that is not publicly owned, show the limits of the **easement** and construction strip on the drawings; see the requirements listed in this section and in Appendix "D" (WSSC Survey and **Easement** Criteria). WSSC will review the widths of both the **easement** and the construction strip for maintenance and constructability due to the depth of the **pipe** and/or soil conditions and make any necessary changes to the widths.
- 2) After determining the limits of the **easement** and construction strips and receiving concurrence from WSSC, prepare the **easement** documents.

### b. Existing Pipeline Width Requirements.

- 1) The widths of existing **easements** shown / provided for existing large diameter pipelines (30-inch and larger) may be inadequate from a public safety, operation and maintenance perspectives. The most serious risks are posed in situations where occupied spaces are built within short distances of large diameter Pre-Stressed Concrete Cylinder Pipe (PCCP). Future design should take this into consideration. WSSC will provide available information and discuss potential design considerations upon request.

### c. Proposed Pipeline Width Requirements.

- 1) For **easement** and construction strip minimum width requirements for water and sewer pipelines, see Tables "20" and "21". WSSC may require an increase in the width of the **easement** and/or construction strip, greater than those indicated in Tables "20" and "21".
- 2) Consider the construction and maintenance requirements when determining the required widths for the construction strip(s) and the **easement(s)**.
  - a) Construction strip(s). Take into account the topography along the alignment, when determining the area necessary to construct the pipeline (i.e., steep side slopes which may require the contractor to bench an area to be able to construct the alignment, deep excavations, etc.). If additional area is required to construct the pipeline due to stockpiling material along the alignment, consider the following items: storing the pipe along the trench; stockpiling stone, gravel and/or select backfill, and excavated trench material; contractor's access along the alignment; trench width and equipment area; and the area along the trench for other construction equipment (i.e., front-end loader, etc.).
  - b) Easement(s). Take into account when determining the width of the **easement**, the area required to facilitate future maintenance, excavation, and repairs. Additional access points along the alignment may be required to facilitate the mobility of equipment and personnel.
    - 1) Provide sufficient **easement width** to minimize the potential for personal injury to the public and/or significant property damage caused by water or sewer pipeline breaks.
    - 2) When practical, provide sufficient **easement width to ensure required clearances as detailed in Part 3, Section 3 (Pipeline Crossings and Clearances)**.





Example: For a normal depth 8-inch sewer, the normal width of an easement would be twenty (20 feet), however in an area that could be developed on either side of the sewer, the easement should be increased to maintain the minimum separation from a building or dwelling of fifteen (15) feet for a total easement width of thirty-one (31) feet.

**TABLE "20"**

**Easement** and Construction Strip Minimum Width Requirements for Water Pipelines

Pipeline Diameter	Width of <b>Easement</b>	Total Width of Construction Strips
12-inch and smaller	20 feet	15 feet
<b>14-inch</b> to 24-inch	25 feet	20 feet
30-inch	30 feet	20 feet
36-inch to 42-inch	40 feet	To be determined by WSSC
48-inch to 66-inch	60 feet	To be determined by WSSC
72-inch and larger	75 feet	To be determined by WSSC

**TABLE "21"**

**Easement** and Construction Strip Minimum Width Requirements for Sewer Pipelines

Pipeline Diameter	Width of <b>Easement</b>	Total Width of Construction Strips
<b>12-inch</b> and Smaller	20 feet	20 feet
15-inch to 24-inch	45 feet	20 feet
30-inch to 36-inch	50 feet	To be determined by WSSC
42-inch and larger	55 feet	To be determined by WSSC

(For **Easement** widths for deep sewers, see information below)

- 3) When the depth of the sewer requires between sixteen (16) to twenty (20) feet of cover for 12-inch and smaller pipeline, provide a thirty (30) feet easement.
- c) Easements for Deep Sewers

- 1) For requirements for Deep Sewers, see Part Two, Section 8 (Vertical Alignment (Profile)).
- 2) For determining width of **easements** for sewer pipelines over twenty (20) feet of cover, use the following:
  - (a) For sewers 12-inch and smaller with depth greater than twenty (20) feet, multiply two (2) feet of **easement** width by each foot of cover pipeline depth. If Deep Sewer is sharing the **easement** with another pipeline, see additional in this section.

Example: For a 12-inch diameter sewer pipeline with twenty-three (23) feet of cover:

2 (feet of **easement**) times 23 (feet of cover) equals 46 feet.

Total **easement** width shall be 46 feet width.

- (b) For sewers 15-inch and larger, with depth greater than **twenty (20)** feet, multiply one (1) foot of **easement** width from the edge of the **easement** to the centerline of the deep sewer for each foot of cover pipeline depth. Also, see requirements for Location of Pipelines Within **Easements** and Construction Strips in this section



Example: For a 15-inch diameter sewer pipeline with twenty-three (23) feet of cover: 1 (feet of **easement**) times 23 (feet of cover) equals 23 feet for both pipelines (new sewer and future relief sewer).

Offset the sewer for future relief sewer, add minimum of 10 feet separation  
Total **easement** width shall be 56 feet width.

**d. Location of Pipelines Within **Minimum Easements** and Construction Strips.**

- 1) **Only one (1) pipeline within the **easement**.** Typically, locate one pipeline **only** in the center of the **easement** and **divide** equally the construction strip on both sides of the **easement**, except for the following **instances**:
  - a) **Water pipelines 48-inch to 66-inch**, provide a minimum of twenty-five (25) feet from the OD of the pipeline to the **easement** line, for total minimum width of the **easement**, see Table "20".
  - b) **Water pipelines 72-inch and larger**, provide a minimum of thirty (30) feet from the OD of the pipeline to the **easement** line, for total minimum width of the **easement**, see Table "20".
  - c) **Sewer pipelines 15-inch and larger**, If depth of cover is less than twenty (20) feet, provide a minimum distance of **twenty-two and one half (22.5)** feet from the **easement** line to the centerline of the pipeline, for total minimum width of **easement**, see Table "21". If depth of cover is twenty (20) feet or more, see **Easements** for Deep Sewers in this section. **If a future relief sewer is required by WSSC's Planning Group, provide sufficient easement to ensure required clearances as detailed in Part 3, Section 3 (Pipeline Crossings and Clearances).**

Example: For a normal depth 8-inch sewer, the normal width of easement would be (twenty (20) feet, however in an area that could be developed on either side of the sewer, the easement should be increased to maintain the minimum separation from a building or dwelling of fifteen (15) feet for a total easement of thirty-one (31) feet.

- 4) **Two (2) pipelines within the same **easement** and parallel to each other.**
  - a) **Existing **Easements**.** Research the recorded documents for existing rights of way, to see if another pipeline can occupy the existing **easement**.
    - 1) If the recorded documents state that it is for one pipeline, prepare a new **easement** document for the proposed pipeline.
    - 2) If the recorded documents state that it is for one or more pipelines, then see if the spacing of the proposed and existing pipelines are within the requirement for Minimum Spacing Requirements Between Two (2) Pipelines **as detailed in Part 3, Section 3 (Pipeline Crossings and Clearances)**. If the existing **easement** is not large enough to suit the required spacing, prepare a new **easement** document for the additional **easement** required.
  - b) **Proposed **Easements**.** If the design requires two pipelines to occupy the same **easement**, the proposed **easement** documents must include in the description the right to have more than one pipeline occupy the **easement**.



- c) Minimum separation requirements between two pipelines parallel to each other. Refer to Part Three, Section 3 (Pipeline Crossings and Clearances).
- d) Additional spacing requirements between two pipelines parallel to each other.
  - (1) If the soil boring logs show that rock will be encountered during the construction, determine if the distances stated above will be safe for blasting the trench if one (1) of the pipelines is existing.
  - (2) If one (1) of the pipelines is existing and the area over the existing pipeline will be used for the construction of the new pipeline, evaluate the impact of the construction over the existing pipeline. Construction over an existing pipeline should not add any additional pipe loading, which includes heavy construction equipment (exceeding AASHTO H20 loading), trench spoils, etc., unless calculations are submitted showing that the existing pipeline will not be jeopardized due to the additional pipe loading. Information may have to be added to the contract limiting the types of activities, types of construction equipment, etc., permitted in the area above the existing pipe.
  - (3) When one of the new pipelines is 15-inch or larger and parallel to an existing pipeline, provide a minimum working area of twenty five (25) feet on the opposite side of the new pipeline. (Combination of both the **easement** and construction strip).

**e. Easement for Water Pipeline Appurtenances.**

- 1) Fire hydrants: provide a minimum twelve (12) foot wide of the **easement**, **width of** six (6) feet on each side of the fire hydrant and extended six (6) feet behind the fire hydrant and construction strip is necessary.
- 2) Meters (box, vaults, etc.) and structures: provide an **easement** a minimum of ten (10) feet on each side of the outside edge of the vault wall, meter box, pipeline, (i.e., bypass line), etc.

**f. Construction Strips.**

- 1) Typically, the construction strip is equally divided on both sides of the **easement**. The location, type and size of the pipeline may require the construction strips to vary in size and location.
- 2) When one side of the **easement** cannot be used for construction, i.e., stream location, steep slopes, etc., provide the total width of the construction strip on the side that can be used for construction.
- 3) When the proposed pipeline is parallel to an existing pipeline, provide the construction strip adjacent to the new pipeline **easement**.
- 4) State in the **easement** documents whether the contractor has the right to cut trees within the construction strip. The need to cut trees in the construction strip will be determined after the design review stage.



**g. Access Points Along the Easement.**

- 1) Provide adequate access along the pipeline **easement**. Access points are to allow for entry to the **easement** so that traversing of private property will not be required. The exact distance between the access points can be varied slightly to be cost effective.
- 2) For 48-inch and larger water pipelines, design access points along the **easement** every six-hundred (600) feet, unless otherwise directed by WSSC.

**h. Property of the Maryland National Capital Park and Planning Commission (MNCPPC).**

- 1) In most cases, MNCPPC requires permits for the construction of pipelines within park property. Show the total working area required to construct the pipeline(s) on the drawings. Include both the width of the **easement** and construction strips in the total working area. Indicate the total working area on the drawings as "WORK LIMITS". Verify with MNCPPC for requirements within their property.

**i. Potomac Electric Power Company (PEPCO).**

- 1) In some cases, PEPCO owns a utility **easement** through a road easement. This may require WSSC to obtain **an easement** from PEPCO within a road easement.
- 2) No structures (manholes, vaults, etc.) are permitted within a PEPCO **easement**, unless approved by PEPCO.
- 3) Design pipeline crossings of PEPCO rights of way at ninety (90°) ± degrees and indicate the distances to PEPCO towers, etc. to reference the location.
- 4) Verify PEPCO requirements within its **easement**.



### 3. Pipeline Crossings and Clearances.

#### a. General.

- 1) When determining pipeline clearances, measure the distance between pipelines or utilities, from the outside diameter (OD) or edge of each pipe or utility unless otherwise noted.
- 2) Water and Sewer Pipelines.
  - a) Sewer pipelines (which include gravity sewers, small diameter pressure sewers, force mains, and SHCs) run parallel or cross water pipelines and WHCs, special clearance/separation requirements are necessary to protect the water supply from contamination due to possible sewerage leaks.
  - b) For other requirements see this section.
- 3) Tunnels Crossings.
  - a) For crossing and clearance requirements for tunnels, see Part Three, Section 26, Tunnel Design Criteria

#### b. Vertical Clearances for Pipeline or Utility Crossings.

- 1) Provide a minimum one and half (1'-6") foot vertical clearance between water and sewer pipelines and when water and sewer pipelines are crossing other utilities provide minimum one (1'-0") foot of vertical clearance at the closest points of the pipelines. Note that for pipeline crossing with either pipeline at a slope, the closest point will not be at the centerline crossing of the pipes.
- 2) If water vertical clearance between sewer pipeline cannot be met, provide at least six (6") of vertical clearance, install Polyethylene Mesh on the lower pipeline, see Detail C/1.9 and provide sand cushion between the water and sewer pipelines.
- 3) If sewer vertical clearance between water pipeline cannot be met, provide at least six (6") of vertical clearance, use either PVC AWWA C900 pipe or ductile iron pipe for the sewer pipeline and center a nominal full length (18 to 20 foot) at the crossing of the water pipeline, install Polyethylene Mesh on the lower pipeline, see Detail C/1.9 and provide sand cushion between the water and sewer pipelines.
- 4) If vertical clearance between water or sewer pipeline with other utility cannot be met, provide at least six (6") of vertical clearance, install Polyethylene Mesh on the water or sewer pipeline, see Detail C/1.9 and provide sand cushion between pipe and other utility.
- 5) For pipelines that are not crossing at angles less than ninety (90°) degrees horizontally, or when one of the pipelines or conduits has a diameter width of larger than thirty (36) inches, or when one of the pipes is at a slope larger than ten (10) percent calculations or sketch that verify inverts must be shown on a profile on the drawings.

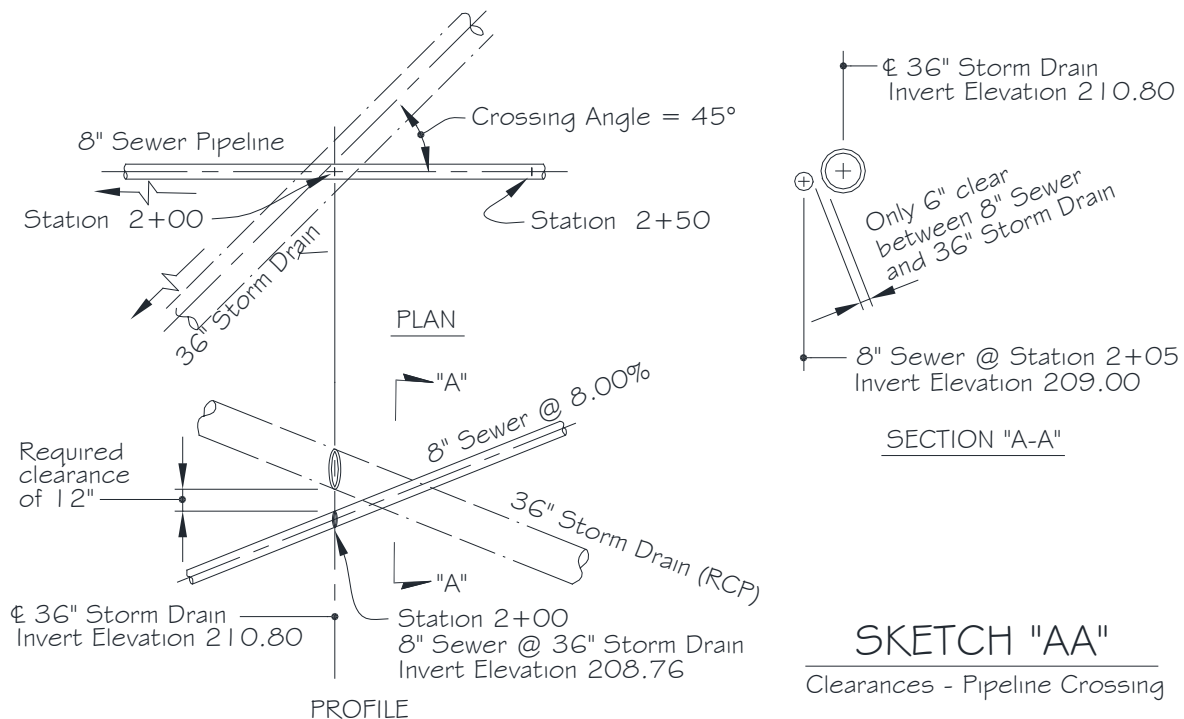

**Example:**

8-inch sewer at station 2+00 crosses a 36-inch storm drain at an angle of 45°. At the centerline of the two pipelines, the design shows that the two pipelines have a 12-inch clearance, but at station 2+05 the two pipelines have only 6-inch of clearance. This is due to the slope of the two pipelines; see "Section" of Sketch "AA".

To have the required pipe clearance at the centerline of the two pipelines, the clearance at station 2+00 will need to be at least two (2) feet so that the centerline crossing will have the required one (1) foot clearance over the entire pipeline crossing, see Sketch "AA".

- 6) The minimum vertical clearance for other jurisdiction's utilities, is governed by that utility (i.e., Colonial Pipeline requires a minimum of two (2) feet of vertical clearance).

**c. Working Within Maryland Transit Administration (MTA) Rail Lines.**

- 1) Locations of water and sewer pipelines (which include water mains and gravity sewers, small diameter pressure sewers, force mains SHCs, and WHCs, manholes, vaults, valves and fire hydrants) shall not be located with the MTA Rail Line of Influence, see Sketch "UU".
- 2) When within the MTA Rail Line of Influence install the water and sewer pipelines in a casing pipe, see Casing Pipe Lengths, Section 26 (Tunnel Design Criteria) and Sketch



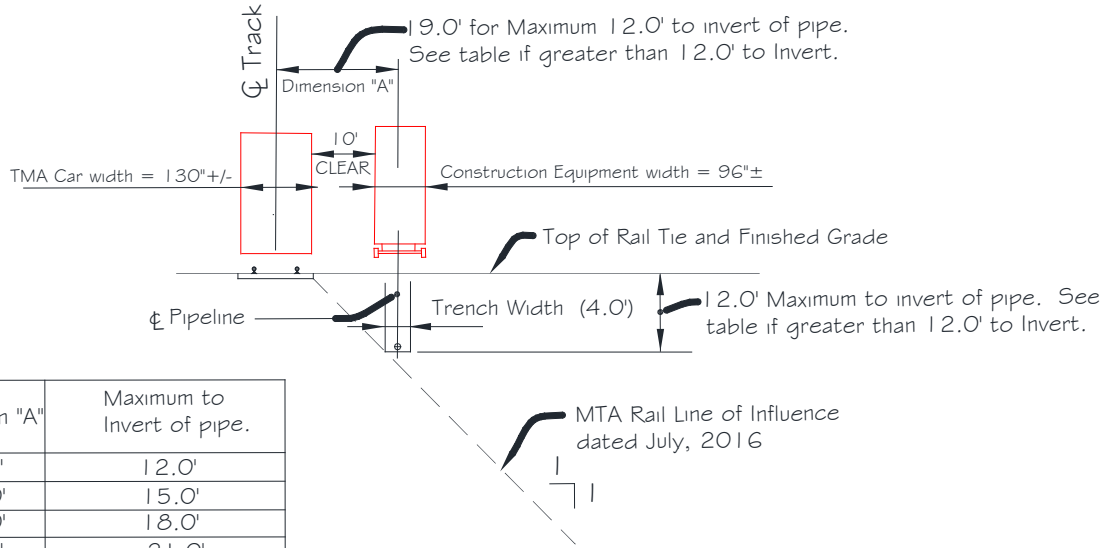

Notes:

1. Pipe trench or structure trench must be out of the MTA Rail Line of Influence.
2. For over 28' of cover must be approved by WSSC - Technical Services Group.

SKETCH "UU"

MTA Light Rail Zone of Influence

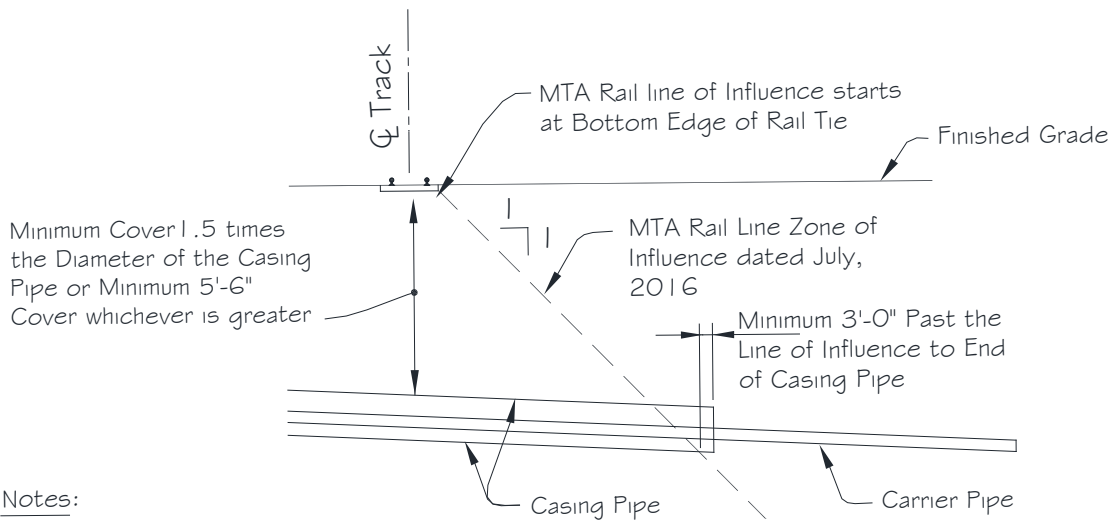

Notes:

1. All pipelines crossing under MTA Rail Line and within MTA Rail Line of Zone of Influent must be in a casing pipe.
2. Pipe trench or structure trench must be out of the MTA Rail Line of Influence.

SKETCH "VV"

Profile of Tunnel Crossing MTA Rail



**d. Horizontal Separation With Other Utilities/Structures.**

- 1) Provide a minimum of five (5) feet horizontal separation between water/sewer pipelines and other utilities and structures (manholes, inlets, vaults, poles, etc.).
- 2) Provide the following minimum separation when a water/sewer pipeline is parallel or adjacent to existing or proposed buildings or dwellings:

**a) Water Pipelines.**

- (1) For water pipelines 12-inch and smaller in diameter, provide a minimum separation from a building or dwelling the greater of the following: fifteen (15) feet horizontal separation or **distance on a 1:1 slope** from the bottom of the foundation of the existing or proposed building or dwelling to the bottom edge of the pipeline trench.
- (2) For water pipelines larger than 12-inch diameter, the minimum separation from a building or dwelling is to be determined based on the following factors; **maintain a minimum horizontal separation of twenty-five (25) feet and consider potential property damage and physical injury during construction, maintenance and failure of the pipeline in assessing whether a greater separation is warranted. Select the separation so that the existing or proposed foundation of the building or dwelling will not be damaged during the construction, maintenance and failure of the pipeline.**

**b) Sewer Pipelines.**

- (1) For sewer pipelines 12-inch and smaller in diameter, provide a minimum separation from a building or dwelling the greater of the following: fifteen (15) feet horizontal separation or **a distance on a 1:1 slope** from the bottom of the foundation of the existing or proposed building or dwelling to the bottom edge of the pipeline trench.
  - (2) For sewer pipelines larger than 12-inch diameter, the minimum separation from a building or dwelling is to be determined based on the following factors: **maintain a minimum horizontal separation of twenty-five (25) feet and consider potential property damage and physical injury during construction, maintenance and failure of the pipeline in assessing whether a greater separation is warranted. Select the separation so that the existing or proposed foundation of the building or dwelling will not be damaged during the construction, maintenance and failure of the pipeline.**
- 3). Minimum separation requirements between existing and proposed or relocated water pipelines, where the existing water line is to remain in service.
    - a) For water pipelines 14-inch and smaller in diameter, provide a minimum of ten (10) feet separation centerline to centerline of the two pipelines.
    - b) For water pipelines 16-inch to 24-inch in diameter, provide a minimum of ten (10) feet separation OD to OD of the two pipelines.
    - c) For water pipelines 30-inch and larger in diameter, provide a minimum of twenty (20) feet separation OD to OD of the two pipelines.





- d) Horizontal separation between the existing and proposed **water** pipelines may have to be increased when the pipeline is within the zone of influence of existing concrete blocking. To determine if there is adequate passive soil resistance, see Passive Soil Pressure for Concrete Thrust Blocks in Part Three, Section 27 (Thrust Restraint Design for Buried Piping).
- 4) Minimum separation requirements between existing and relocated sewer pipelines where the existing sewer is to remain in service until the relocation is complete.
- a) **For sewer** pipelines smaller than 14-inch diameter, provide a minimum of ten (10) feet separation, centerline to centerline of the two pipelines.
- b) **For sewer** pipelines 14-inch to 24-inch diameter, provide a minimum of ten (10) feet separation, OD to OD of the two pipelines.
- c) **For sewer** pipelines larger than 24-inch diameter, see requirements below for minimum separation requirements between relief sewers and original sewer pipelines.
- 5) Minimum separation requirements between relief sewers and original sewer pipelines.
- a) If both pipelines are 36-inch and smaller diameter, provide a minimum of twenty (20) feet separation, centerline to centerline of the two pipelines.
- b) If one or both pipelines are larger than 36-inch diameter, provide a minimum of twenty five (25) feet separation, centerline to centerline of the two pipelines.
- 6) Minimum separation requirements between an existing or new sewer and a new force main.
- a) If both pipelines are 12-inch and smaller diameter, provide a minimum of ten (10) feet separation, centerline to centerline of the two pipelines.
- b) If either pipeline is larger than 12-inch diameter, provide a minimum of ten (10) feet separation, OD to OD of the two pipelines.
- 7) Horizontal Separation Between Sewer and Water Pipelines.
- a) When a sewer is parallel to a water pipeline, provide ten (10) feet minimum horizontal separation, see Standard Detail M/18.0.
- b) Where sewers and water pipelines are less than ten (10) feet apart horizontally, design the bottom of the water pipeline with a minimum of eighteen (18) inches **of** vertical clearance above the top of the sewer pipeline; see Standard Detail M/18.0.
- c) **Minimum separation requirements when sewer and water pipelines is parallel to an existing PCCP water pipeline:**
- (1) **For an existing 16-inch to 24-inch PCCP water pipeline in diameter, provide a minimum of ten (10) feet separation OD to OD of the sewer or water pipelines.**



(2) For an existing 30-inch and larger PCCP water pipeline in diameter, provide a minimum of twenty (20) feet separation OD to OD of the sewer or water pipelines.

8) No structures will be allowed over WSSC pipelines.

9) If it is impossible to obtain the vertical separation between the water and sewer pipelines as stated above, see Alternative – When Water and Sewer Clearances Cannot Be Met, in this section.

**e. Crossing Under Existing Pipelines and Utilities.**

1) When crossing under an existing critical pipeline or other utility with a new pipeline(s), special precautions and provisions are necessary in the design to avoid damage and minimize future settlement of the existing utility. Consider the following pipelines and utilities as critical:

- a) All sizes of Prestressed Concrete Cylinder Pipes (PCCP), both water and sewer.
- b) All ductile iron water and sewer pipelines larger than 24-inch diameter.
- c) All non-PVC sewer pipes equal to and larger than 18-inch diameter.
- d) Any other critical utility identified on a case by case basis such as electrical ductbanks, etc.

2) The necessary precautions and provisions to be considered in the design of new pipelines crossing under existing utilities are as follows:

a) Supporting the existing pipe or utility across the proposed trench. This is accomplished by limiting the proposed pipe trench width so that the existing pipe is self-supporting or specially designing a support. New water and sewer pipelines that are installed according to the Specifications will be built using standard trench widths indicated in Standard Detail M/8.0.

(1) Generally, it is the responsibility of the contractor to provide support as necessary when trenching under existing utilities. This provision is included in the Specifications; therefore, special design typically is not required.

(2) If there is considerable interest in protecting the existing pipeline or utility which may be undermined by a wide trench, etc. and if directed by the WSSC provide a design for the support of the excavation and the utility as part of the contract documents; see Part Three, Section 18 (Temporary Construction Support Criteria).

b) Restoring a firm foundation and bedding. Restore a firm foundation and bedding for the existing utility to minimize future settlement and maintain the structural strength of the pipe.

(1) When the design calls for crossing under the critical pipelines listed in 1) a) through c) above, provide a note on the drawings, both plan and profile, referring to Standard Detail M/8.3. This detail calls for replacing disturbed earth under and to 1'-0" above the existing pipeline with compacted structural fill.

(2) For special crossing situations, such as 1) d) above, provide the special design and details



for backfilling under the utility.

**f. Vertical Separation For Gravity and Pressure Sewer Pipelines Crossing Water Pipelines.**

- 1) When the sewer is below the water, provide minimum **one and half (1'-6")** feet of vertical clearance.
- 2) When the sewer is above the water, provide minimum **one and half (1'-6")** feet vertical clearance and design the new pipeline with one full eighteen (18) to twenty (20) foot nominal pipe length centered at the crossing. If the design requires pipe bedding for the new pipes, provide a compacted well graded material such as special borrow material, in accordance with the Specifications, for a minimum of ten (10) feet on each side of the crossing.
- 10) If it is impossible to obtain the vertical separation between the water and sewer pipelines as stated above, see Alternative – When Water and Sewer Clearances Cannot Be Met, in this section.

**g. Horizontal Separation Between SHC and WHC.**

- 1) Separate Trench; provide ten (10) feet minimum horizontal separation between gravity SHC and WHC when they are designed in separate trenches.
- 2) Common or Combined Trench, when the WHC and SHC are designed in a common or combined trench see Standard Detail M/18.0 for the horizontal and vertical clearances and the following:
  - a) If a ductile iron WHC and SHC are less than ten (10) feet apart horizontally, design the bottom of WHC with a minimum of eighteen (18) inches vertical clearance above the top of the SHC and a minimum of eighteen (18) inches horizontal separation.
  - b) If a copper pipe WHC and SHC are less than ten (10) feet apart horizontally, design the bottom of WHC with a minimum of **eighteen (18)** inches vertical clearance above the top of the SHC and a minimum of eighteen (18) inches horizontal separation.
- 3) Provide ten (10) feet minimum horizontal separation between Pressure Sewer House Connection (PSHC) and WHC when designed in separate trenches. Do not design PSHC's and WHC's in a common or combined trench. Where PSHC and WHC are less than ten (10) feet apart horizontally, design the bottom of WHC with a minimum of eighteen (18) inches vertical clearance above the top of the PSHC.

**h. Alternatives - When Water and Sewer Clearances Cannot Be Met.**

- 1) If it is impossible to obtain the vertical and horizontal separations between water and sewer pipelines as stipulated in "Vertical Separation For Gravity and Pressure Sewer Pipelines Crossing Water Pipelines" and "Horizontal Separation Between Sewer and Water Pipelines" in this section, then specify one or more of the following alternative methods for the section of the pipeline which is less than the required clearance.
- 2) Prior to specifying these alternatives, consider re-aligning the pipeline to meet the required vertical and horizontal separations between water and sewer pipelines, unless it is more cost



effective to use the alternative methods.

3) Alternative Methods.

- a) Slip lined sewer pipelines. Nothing additional is required if the existing or proposed sewer pipeline are slip lined with an approved continuous liner such as the following.
- (1) Slip line existing sewer pipeline. Review the Sewer 200-foot reference sheets to determine if the existing sewer in question has been lined. See example of 200-foot reference sheet below. Provide a note on the drawings indicating that the existing sewer has been lined.

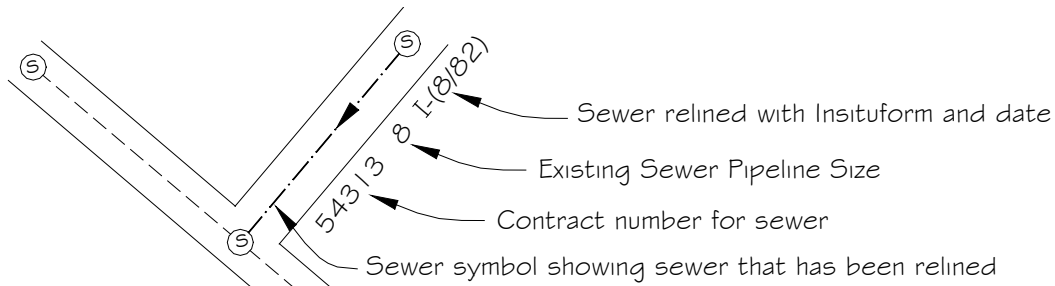

- (2) Slip lined water pipeline. The allowable water pipeline liner is a steel pipe liner with welded joints.
- b) Pipe bell joint leak clamps. Provide pipe bell joint leak clamps on either the water or sewer pipeline. Provide special provisions to the Specifications; see Part Three, Section 6 (Modifications to Specifications and Standard Details). Indicate the limits of the bell clamps, which should include the section of the pipeline where there is less than the required clearance on the drawings.
- c) Concrete encasement of existing sewer pipelines. Provide concrete encasement on the existing sewer pipeline joints, at least one (1) foot minimum on both sides of the joint and in accordance with Standard Detail M/9.0. (Do not encase in concrete PVC sewer pipelines) For the allowable sewer pipeline materials which can be encased in concrete, see Part Three, Section 13 (Concrete Encasement, Arches and Cradles). Nothing additional is required if the existing sewer pipeline is already encased in concrete. Provide a note on drawings indicating the limits of the existing concrete encasement.
- d) Tunnel or casing pipe. If either or both the existing or proposed water or sewer pipelines are within a tunnel or casing pipe as indicated below, nothing additional is required. Provide a note on the drawings stating that the existing pipeline is within a tunnel or casing pipe.
- (1) The water pipeline or pressure sewer is to be within a continuous welded joint steel casing pipe, in accordance with Standard Details M/17.1 or M/17.7.
- (2) The gravity sewer pipeline is to be within a tunnel or casing pipe that is filled with concrete, in accordance with Standard Detail M/17.0.



- e) Special pipe materials. If the water or sewer pipeline is one of the following pipe materials, nothing additional is required: Steel Pipe with welded joints, Prestressed Concrete Cylinder Pipe with continuous welded joints, High Density Polyethylene Pipe (HDPE) with butt fusion joints or solvent welded PVC pipe. Provide note on the drawings indicating the type of material.
  - f) Upgrade the sewer pipe material. If the existing or proposed sewer pipeline material is one of those used for water pipelines, see Part One, Section 2 (Pipe Materials and Fittings), nothing additional is required.
  - g) Replace the sewer pipeline. If the existing pipe material is either of PVC **AWWA C900** pipe or ductile iron pipe at the pipe crossings, replace the existing sewer pipeline with a nominal full length (18 to 20 foot) **of the same pipe material** centered at the crossing. For parallel installation, replace the existing sewer pipeline with an upgraded sewer pipe material, as specified in this section.
- i. Working in the Vicinity of Existing **PCCP 30-inch and Larger Water Mains**.**
- 1) **The following** notes are to be added to construction plans used for paving and grading above Existing **PCCP 30-inch and Larger Water Mains**

**SPECIAL CONSTRUCTION REQUIREMENTS FOR WORK PERFORMED  
IN THE VICINITY OF THE EXISTING (fill in type, size of pipe)**

1. Construction vehicles generating a load greater than an AASHTO H20 and vibratory compaction equipment are not permitted within ten (10) feet clear of the existing \_\_\_" PCCP Water Main(s).
2. The Contractor shall submit construction vehicle specifications for all vehicles to be used closer than ten (10) feet clear of existing \_\_\_" PCCP Water Main(s) to the WSSC **Technical Services Group** for WSSC approval prior to commencing work over the mains.
3. Stockpiling of soil or other material is not permitted within ten (10) feet clear of the mains.
4. The contractor shall locate and stake out the existing \_\_\_" PCCP Water Mains and maintain the markers during construction. Unless otherwise approved by WSSC **Technical Services Group**, construction vehicles are not permitted within ten (10) feet clear of the \_\_\_" PCCP Water Main(s) at any time.
5. All backfill and compaction over the \_\_\_" PCCP Water Main(s) with less than 3'-0" of soil cover must be performed manually and/or with vehicles positioned a minimum of 10 feet clear of the main(s) until 3'-0" of cover is achieved. If necessary, temporary fill shall be placed over the existing mains to allow WSSC approved vehicle traffic to cross over the pipeline.
6. All exposed rocks, broken pavement, curbing and other unyielding debris having any dimension greater than three inches shall be removed from above the main(s) prior to placing and compacting fill, subgrade materials or paving over the main.



7. The contractor shall notify the WSSC Construction Inspector \_\_\_\_\_ at telephone number \_\_\_\_\_ at least \_\_\_ days in advance of any grading or paving in the vicinity of the existing PCCP Water Main(s). All grading and paving over the mains shall be coordinated and performed under the supervision of the WSSC Construction Inspector.
  8. The contractor shall use special care while performing work in the vicinity of the existing \_\_\_ " PCCP Water Main(s) where less than 3'-0" of soil cover exists and strictly adhere to these special construction requirements. The Contractor is responsible for any damage and/or replacement required as result of his work over the mains.
- j. Requirements for construction across or in vicinity of City of Rockville's Existing 24-inch Water Transmission main.**

- 1) Provide the following notes on the drawings;

**REQUIREMENTS FOR CONSTRUCTION ACROSS OR IN VICINITY OF CITY OF ROCKVILLE'S EXISTING PCCP 24" WATER TRANSMISSION MAIN.**

1. The City of Rockville Utilities Superintendent is to be notified at 240-314-8567 at least 48 hours prior to commencement at any type of construction.
2. During construction adequately protect the City's facilities from crossing on the Right of Way over the City's waterline.
3. Under no circumstances will heavy equipment of any type be permitted to excavate or work directly over the City's waterline.
4. All excavation will be performed by hand over the City's waterline or within six (6) feet of each side with the City's inspector standing by.
5. Under no circumstances will there be any cuts permitted over the city's waterline or within 6 feet of each side without prior agreement with the City and the City's inspector standing by.
6. Compaction of embankment over the City's waterline and for a distance of six (6) feet on each side shall not be accomplished with vibratory equipment.



## 4. Buoyancy of Pipelines.

### a. General.

- 1) The possibility of pipe flotation exists when the pipeline is constructed in areas which will be inundated, such as stream crossings, flood plains and high ground water areas. When such conditions exist, evaluate the possibility of pipe flotation.
- 2) The buoyancy of a pipeline depends upon the weight of the pipe, the weight of the volume of water displaced by the pipe, the weight of the liquid load carried by the pipe and the weight of the backfill. As a conservative analytical practice, consider the pipeline empty for two reasons; so the weight of the liquid will be considered as an additional safety factor and the possibility of the pipeline not being in use during a period of time.

### b. Design Procedures.

- 1) The first step. Determine if the pipeline will float with no backfill material. The sum of the pipe weight and weight of displaced water will determine if the pipeline will float. This can be calculated by:
  - a) Pipe weight. Weight of pipe to be determined by selecting the pipe material to be used and finding the weight per linear foot. (Include the weight of the bell joint and appurtenances). Obtain this information from the approved manufacturer's published product data giving the actual dimensions, weights per linear foot, etc. If the manufacturer's data is not available, the information provided in this section can be used.

$W_p$  = weight of pipe per linear foot (downward force ↓, positive)

- (1) ASTM C76, Reinforced Concrete Pipe (RCP). The Specifications do not give the requirements for wall thickness, but references ASTM C76 standards. ASTM C76 specifies three wall thickness (A, B and C), with the thinnest wall being Wall "A". Unless otherwise specified in the Specifications or on the drawings, calculate the pipe weight using the weight of RCP Wall "A" pipe. To obtain the pipe weight for RCP, contact the approved manufacturers for RCP. The approximate weight of RCP can be calculated, using the following equation. This calculation will provide the average density of concrete without reinforcing steel. If the pipe requires additional weight, specify wall thickness Wall "B" or "C".

$$W_p = (\pi \div 4) (B_c^2 - D^2) 150 \text{ lb/ft}^3$$

Where:

Unit weight of plain concrete = 150 lb/ft<sup>3</sup>.

$W_p$  = weight of pipe per linear foot, (downward force ↓, positive)

$B_c$  = outside pipe diameter (feet)                       $D$  = inside pipe diameter (feet)

- (2) Ductile Iron Pipe (DIP). Determine the thickness of DIP, see Part One, Section 4 (Selection of Pipe Material), and for weight of DIP, see AWWA C151. If the pipe requires additional weight, a higher class of DIP can be specified.



- (3) Polyvinyl Chloride Pipe (PVC). PVC is a light weight pipe material, for the weight of pipe, contact the approved manufacturers of PVC. If pipe flotation occurs when using PVC pipe, change the pipe material.
- b) Displaced water weight. When water is displaced, a buoyant or upward force exists. If the buoyant force is greater than the weight of the object displacing the water (which is the pipe), flotation will occur. The density of fresh water is 62.4 pounds per cubic foot and the average density of seawater is 64.0 pounds per cubic foot. The density of brackish water will be between that of fresh and seawater depending upon the degree of salinity. Investigate local conditions for the specific project. For computations, using the density of fresh water (62.4 lb/ft<sup>3</sup>), will provide sufficient accuracy. The weight of fresh water per linear foot of circular pipe can be calculated by using the following equation:

$$W_w = (\pi \div 4) (B_c^2) 62.4 \quad (W_w \text{ is always negative, upward force } \uparrow)$$

Where:

$$\begin{aligned} \text{Unit weight of fresh water} &= 62.4 \text{ lb/ft}^3 & B_c &= \text{outside pipe diameter (feet)} \\ W_w &= \text{weight of displaced water, pounds per linear foot (upward force } \uparrow, \text{ negative)} \end{aligned}$$

- c) Summation of forces. After determining the pipe weight and weight of displaced water, add the sum of  $W_p$  and  $W_w$  and the resultant of the forces will determine if the weight of pipe will be adequate to prevent flotation. If the resultant force is positive, the pipe will not float. If the resultant force is negative, the pipe by itself will float. Determine the weight of backfill directly over the pipe necessary to prevent flotation as outlined in Step 2 below. This can be calculated by:

$$W_t = W_p + W_w$$

Where:

$$\begin{aligned} W_w &= \text{weight of displaced water, pounds per linear foot (upward force } \uparrow, \text{ negative)} \\ W_p &= \text{weight of pipe, pounds per linear foot, (downward force } \downarrow, \text{ positive)} \\ W_t &= \text{resultant buoyant force of the submerged pipe, pounds per linear foot} \end{aligned}$$

- 2) The second step. The weight of the backfill directly over the pipe assists in resisting buoyant forces. The unit weight of compacted backfill material varies with the material, grain size, degree of compaction, etc. For computations, the average values for specific gravity and unit weight of backfill material provide sufficient accuracy.
- a) The average unit of weight of inundated backfill is equal to the dry density of the backfill minus the weight of the water displaced by the solid particles and can be calculated as follows:

$$w_I = w - [(w \div (SG \times 62.4)) \times 62.4]$$

Where:

$$\begin{aligned} w_I &= \text{average unit weight of inundated backfill, pounds per cubic foot} \\ w &= \text{average unit weight of dry backfill, pounds per cubic foot} \\ SG &= \text{specific gravity of backfill material} \end{aligned}$$

For computations, assume sandy soil,  $w = 110$  and  $SG = 2.65$ , this will provide sufficient accuracy. Certain conditions may require soil investigations to determine the actual soil conditions. Assuming sandy soil, the computations for the average unit weight of inundated backfill, computed as follows:





$$\begin{aligned}
 w_I &= w - [(w \div (SG \times 62.4)) \times 62.4] \\
 &= 110 - [(110 \div (2.65 \times 62.4)) \times 62.4] \\
 &= 110 - [0.67 \times 62.4] \\
 w_I &= 68 \text{ pounds per cubic foot}
 \end{aligned}$$

b) The different volumes of backfill over the pipe to be considered are illustrated in Figure "B".

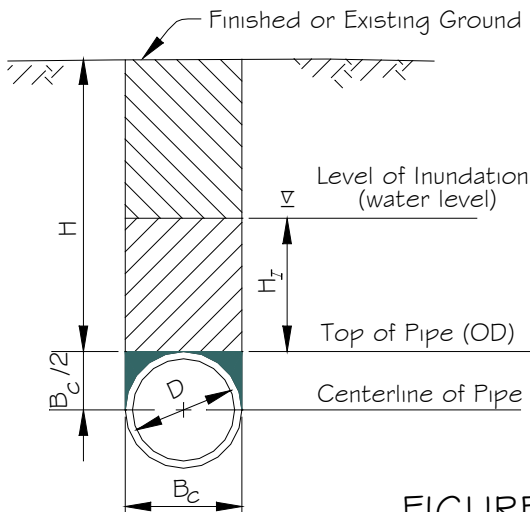

Where:

- H = depth from top of pipe to surface of backfill, feet
- H<sub>I</sub> = depth of inundated backfill above top of pipe, feet
- B<sub>c</sub> = outside pipe diameter, feet
- D = nominal pipe diameter, feet
- B<sub>c</sub> / 2 = the radius of the outside diameter of the pipe, feet

**FIGURE "B"**  
Backfill Volumes Over Pipe

c) Weight of inundated backfill, acting downward per linear foot of pipe can be calculated by:

$$W_I = w_I (0.1073 B_c^2 + H_I B_c)$$

Where:

- W<sub>I</sub> = weight of inundated backfill directly over the pipe, pounds per linear foot
- w<sub>I</sub> = average unit weight of inundated backfill, pounds per cubic foot
- B<sub>c</sub> = outside pipe diameter, feet
- H<sub>I</sub> = depth of inundated backfill above top of pipe, feet

d) Weight of backfill above the water level, if any, acting downward per linear foot of pipe can be calculated by the equation:

$$W_D = w (H - H_I) B_c$$

Where:

- W<sub>D</sub> = weight of the backfill above the water level, pounds per linear foot
- w = average unit weight of dry backfill, pounds per cubic foot
- H = depth from top of pipe to surface of backfill, feet
- H<sub>I</sub> = depth of inundated backfill above top of pipe, feet
- B<sub>c</sub> = outside pipe diameter, feet



- (1) For pipelines crossing streams, assume  $H = H_I$ . This means that the ground water is at the bottom of the stream invert.

$$\begin{aligned} W_D &= w (H - H_I) B_c \\ &= w (0) B_c \\ W_D &= 0 \end{aligned}$$

- (2) In all other cases, determine the ground water conditions.
- e) Therefore, the total weight of backfill acting downward on the pipe is determined from the sums of  $W_D$  and  $W_I$ .

$$W_B = W_D + W_I$$

Where:

$$\begin{aligned} W_B &= \text{total weight of backfill directly over the pipe, pounds per linear foot} \\ W_D &= \text{weight of the backfill above the water level, pounds per linear foot} \\ W_I &= \text{weight of inundated backfill directly over the pipe, pounds per linear foot} \end{aligned}$$

- (1) For pipelines crossing streams,  $W_B = W_I$ . The weight of the material directly over the pipe is to be considered as inundated backfill.
- (2) In all other cases, determine the ground water conditions.
- f) Apply the factor of safety based on the extent of knowledge of the backfill material and site conditions. This factor of safety is applied to decrease the calculated downward force of the backfill acting on the pipe. Factor of safety can be calculated by:

$$W_f = W_B \div \text{FS}$$

Where:

$$\begin{aligned} W_B &= \text{total weight of backfill directly over the pipe, pounds per linear foot of pipe.} \\ &\quad \text{(downward force } \downarrow, \text{ positive)} \\ W_f &= \text{total weight of backfill directly over the pipe with the factor of safety,} \\ &\quad \text{pounds per linear foot of pipe. (downward force } \downarrow, \text{ positive)} \\ \text{FS} &= \text{factor of safety, use 1.5} \end{aligned}$$

- 3) After determining both the upward force due to the displacement of water and the downward force from the backfill material directly over the pipe, determine the resultant upward force  $W_r$  (from  $W_p + W_w$ ) and the downward force  $W_f$  (from  $W_B \div \text{FS}$ ).
- a) If the resultant is positive (downward  $\downarrow$ ), the pipe will not float.
- b) If the resultant force is negative (upward  $\uparrow$ ), select and analyze the procedures required to prevent flotation.



- 4) To determine the minimum height of inundated backfill necessary to prevent flotation during construction, the force exerted by the inundated backfill must equal the buoyant force of the pipe and can be calculated by:

$$W_t = [w_I (0.1073 B_c^2 + H_I B_c)] \div FS$$

$$H_{Im} = (FS W_t \div w_I B_c) - 0.1073 B_c$$

Where:

- $W_t$  = resultant buoyant force of the submerged pipe, pounds per linear foot  
 $w_I$  = average unit weight of inundated backfill, pounds per cubic foot  
 $B_c$  = outside pipe diameter, feet  
 $H_I$  = depth of inundated backfill above top of pipe, feet  
 $H_{Im}$  = minimum depth of inundated backfill required above top of pipe, feet  
 $FS$  = factor of safety

### c. Preventive Procedures.

- 1) Procedures to prevent flotation when the weight of the pipe and backfill is not adequate include the following:
- Increase wall thickness of pipe or change the pipe to a heavier pipe material.
  - Design concrete collars on the pipe. When computing the volume of concrete per linear foot pipe anchorage, use the submerged weight of concrete. Concrete weighs 150 pounds per cubic foot in the air and 87.6 pounds per cubic foot submerged.

### d. Example.

48" diameter sewer crosses a stream with only two (2) feet of cover.

Determine: Will the empty pipe float in the fully backfilled condition ?

- 1) Select pipe material and determine  $W_p$ , weight of pipe.

$$48" \text{ RCP, Wall B weight per linear foot} = +963 \downarrow$$

- 2) Determine  $W_w$ , displaced water weight.

$$W_w = (\pi \div 4) (B_c^2) 62.4 \quad B_c = 58" \text{ or } 4.833'$$

$$= 0.7844 (4.833^2) 62.4$$

$$W_w = -1144.93 \text{ pounds per linear foot of pipe, say } -1145 \uparrow$$

- 3) Summation of forces.

$$W_t = W_p + W_w$$

$$= +963 \downarrow + (-1145) \uparrow$$

$$W_t = -182 \text{ lb/lf, upward force, pipe will float with no backfill directly over the pipe}$$



4) Determine weight of inundated backfill.

$$\begin{aligned}
 W_I &= w_I (0.1073 B_c^2 + H_I B_c) & w_I = 68, B_c = 4.833, H_I = 2 \\
 &= 68 (0.1073 \times 4.833^2 + 2 \times 4.833) \\
 &= 68 (2.506 + 9.666) \\
 &= 68 \times 12.172 \\
 W_I &= 827.70 \text{ pounds per linear foot of pipe } \downarrow, \text{ say } 828 \downarrow
 \end{aligned}$$

5) Determine weight of backfill above water level. In this case we assume the water level equals the total depth of cover, for a stream crossing.

$$\begin{aligned}
 W_D &= w (H - H_I) B_c & w = 110, H = 2, B_c = 4.833 \\
 &= 110 (2 - 2) 4.833 \\
 &= 110 (0) 4.833 \\
 W_D &= 0
 \end{aligned}$$

6) Determine the total weight of the backfill.

$$\begin{aligned}
 W_B &= W_D + W_I & W_D = 0, W_I = 828 \\
 &= 0 + 828 \\
 W_B &= +828 \text{ pounds per linear foot of pipe } \downarrow
 \end{aligned}$$

7) Factor of safety.

$$\begin{aligned}
 W_f &= W_B \div FS \\
 &= 828 \div 1.5 \\
 W_f &= +552 \text{ pounds per linear foot of pipe } \downarrow
 \end{aligned}$$

8) Summation of forces.

$$\begin{aligned}
 W_t \text{ (from } W_p + W_w) &= -182 \\
 W_f \text{ (from } W_B \div FS) &= +552 \\
 W_f &\text{ is greater, therefore the pipe will not float.}
 \end{aligned}$$

9) Determine the minimum height of inundated backfill necessary to prevent flotation during construction.

$$\begin{aligned}
 H_{im} &= [(FS \times W_t) \div (w_I \times B_c)] - 0.1073 B_c \\
 & \quad FS = 1.5, W_t = 182 \text{ (change } W_t \text{ to positive in this equation), } B_c = 4.833, w_I = 68 \\
 &= (1.5 \times 182) \div (68 \times 4.833) - (0.1073 \times 4.833) \\
 &= (273 \div 328.644) - 0.1967 \\
 H_{im} &= 0.63 \text{ feet}
 \end{aligned}$$

Therefore a minimum depth of slightly more than 8-inches of inundated backfill above the pipe is required to prevent flotation.



**e. Reference.**

- 1) Concrete Pipe Handbook, 1988, by the American Concrete Pipe Association.



## 5. Pipeline Abandonment.

### a. General.

- 1) Existing WSSC pipelines and appurtenances may have to be abandoned due to the impact of new roads or new development, pipeline relocation, replacement of deteriorated facilities, etc. In these cases, abandon the pipeline according to the following requirements.

### b. Requirements.

- 1) Consider the following when abandonment is required:
  - a) Determine whether the pipeline and associated appurtenances and structures, should be abandoned in place, physically removed, salvaged or filled with lean grout or other material.
  - b) Clearly indicate the limits and method(s) of abandonment and/or removal of pipelines, structures and appurtenances on the drawings.
  - c) Sewer Pipelines.
    - (1) Pipe, the method of abandonment of sewer pipelines at manholes is illustrated in Standard Detail S/3.5. For SHCs and sewers 36-inch diameter and larger, methods of abandonment are described in the Specifications.
    - (2) Manholes and structures, the method of abandonment of manholes and structures is provided in the Specifications and Standard Detail S/3.6.
  - d) Water pipelines, the methods of abandonment of water pipelines, WHCs and valve vaults are provided in the Specifications.
  - e) Items to be salvaged, for pipe, fittings, valves, valve boxes, fire hydrants, and other appurtenances and portions of the system that are designated to be removed, indicate on the drawings if the item is to be salvaged (i.e. delivered to the WSSC warehouse). WSSC will advise which of these items are to be salvaged.



## 6. Modifications to Specifications and Standard Details.

### a. General.

- 1) The information in the Standard Details for Construction and General Conditions and Standard Specifications is applicable to many, but not all situations encountered in the design of water and sewer systems within the WSSD. During the preparation of the contract documents, determine if modifications to the Standard Details or **S**pecial **P**rovisions to the Specifications are necessary to suit any special conditions.

### b. Modified Standard Details.

- 1) Many Standard Details contain notes that limit their use to certain situations or conditions. Before referencing a Standard Detail in the design, verify that the Standard Detail is indeed applicable to the situation. Provide notes on the drawings to clearly indicate where the referenced Standard Detail is to be used. Verify with the WSSC that the detail being used is in fact the most up to date.
- 2) In cases where the Standard Detail is not entirely applicable, provide the necessary details on the drawings that accurately reflect the non-standard conditions as follows:
  - a) Minor Standard Detail modifications often may be accomplished by providing a note on the drawings referencing the standard detail such as "See Standard Detail \_/\_.\_, modified as follows ...".
  - b) For major Standard Detail modifications, it is often necessary to draft the Standard Detail on the drawings, showing the modifications so that the detail is applicable to the design condition.

### c. Special Provisions to Specifications.

- 1) If any materials or methods to be shown on the drawings and/or required by the design are not covered in the Specifications, identify and submit to the WSSC, at the design review stage, the technical information necessary to prepare the Special Provisions to the Specifications for these items.
- 2) Consult with the WSSC to determine which party will be responsible for actually preparing the Special Provisions to be included in the contract documents.
- 3) If the WSSC will not be preparing the Special Provisions, request a complete copy of all additional Special Provisions on file with the WSSC that may be applicable to the design.



## 7. Erosion Checks.

### a. Requirements.

- 1) When the existing ground over a pipeline has a slope of twenty (20%) percent or greater, but is less than or equal to fifty (50%) percent, provide trench erosion checks.
- 2) If adequate slope protection (i.e., riprap) is already specified or in place, it is not necessary to incorporate trench erosion checks in the design.
- 3) For extremely steep slopes, greater than fifty (50%) percent, check the soil conditions and investigate further stabilization procedures, see Part Three, Section 22 (Slope Stability).

### b. Design.

- 1) Where ground slopes are twenty (20%) percent or greater but less than or equal to fifty (50%) percent, provide trench erosion checks every fifteen (15) feet along the pipeline.
- 2) On profile show the limits of erosion checks, indicating the number of trench erosion checks, show the station for the pipeline station location for each trench erosion check and a reference to Standard Detail M/3.0. Provide the information stated above on the drawings, as shown in Sketch "BB".

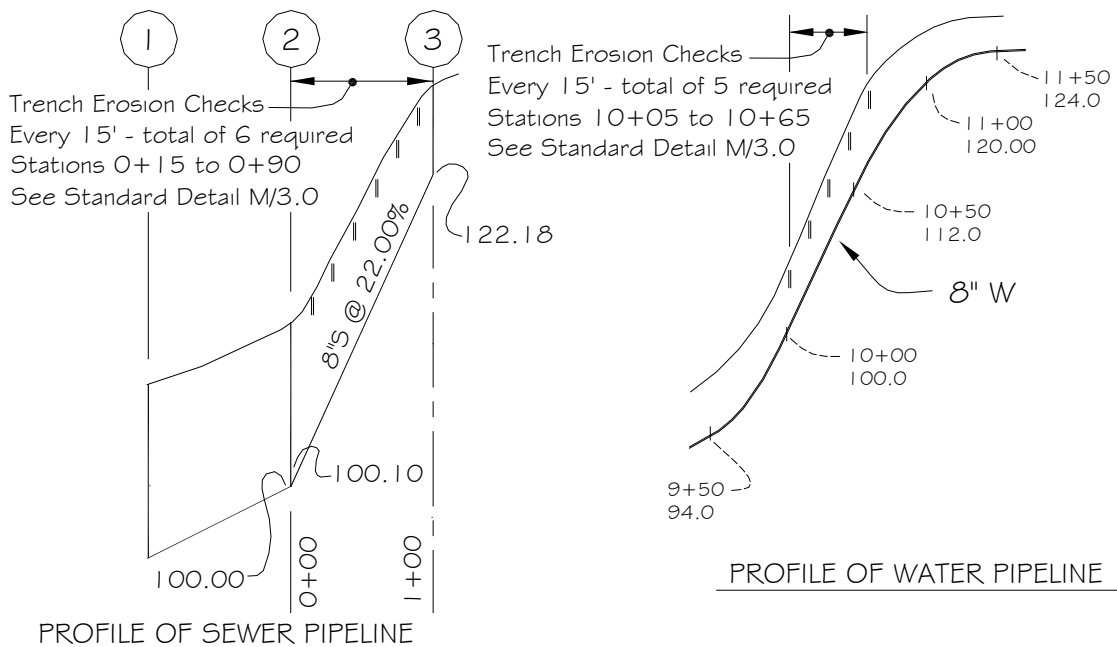

**SKETCH "BB"**  
Trench Erosion Checks for Pipelines





## 8. Erosion and Sediment Control and Tree Protection.

### a. General.

- 1) No land disturbance for the purpose of constructing or maintaining an underground utility may take place without first obtaining a Utility Erosion and Sediment Control Plan Approval and Permit from the Commission, and implementing soil erosion and sediment controls in accordance with an Erosion and Sediment Control Plan approved by the Commission. Land disturbance means any earth movement and land changes which may result in soil erosion from wind and water and the movement of sediment into state waters or onto state lands, including but not limited to tilling, clearing, excavating, trenching, stripping, filling, stockpiling of earth materials, root mat or topsoil removal, the covering of land with an impermeable material, or any combination of these.
- 2) For additional information contact WSSC Technical Group, Environmental Program Unit.
- 3) Information in this section is from Maryland Department of the Environment, latest revision of Environmental Site Design (ESD) Process and Computations.

### b. Utility Erosion and Sediment Control Plan Approval and Permit Acquisition for Utility Construction.

- 1) Requirements for plan approval.
  - a) An applicant shall submit an appropriate detailed erosion and sediment control plan and any subsequently required documents to the Commission for review and approval. The erosion and sediment control plan shall contain sufficient information in engineered drawings and notes to describe how soil erosion and off-site sedimentation will be minimized. The Commission will review the plan to determine compliance with the WSSC Utility Erosion and Sediment Control Regulations and WSSC Specifications and Standard Details prior to approval. The plan shall serve as the basis for all subsequent land disturbance and stabilization.
  - b) The design of the erosion and sediment control will be shown on the drawings, see the design requirements, in this section.
  - c) WSSC Utility Erosion and Sediment Control Permits will only be issued for projects that have obtained plan approval.
- 2) Design Requirements.
  - a) Show the design of the Erosion and Sediment Control on the drawings. The drawings will show where specific erosion and sediment control devices will be installed on the site, and the notes will contain general erosion and sediment control requirements in narrative form. The plan presents a strategy for minimizing erosion and preventing off-site sedimentation, by containing sediment on-site or by passing sediment laden runoff through approved sediment control devices. At a minimum, a Utility Erosion and Sediment Control plan should contain:
    - (1) Delineation of limits of disturbance



- (2) Location and type of erosion and sediment control devices to be installed, and devices already in place if part of an active development site
  - (3) WSSC Utility Erosion and Sediment Control Notse and Standard Detail Sheet SC-1.
  - (4) Delineation of access road and soil stockpile areas
  - (5) Existing and proposed topography 100 feet either side of construction area. (For utility construction areas not contained within a project site subject to county or Soil Conservation District subdivision grading and sediment control approval, provide contours at two (2) foot intervals)
  - (6) Delineation of waterways, streams, 100 year floodplain, and wetland boundaries for any water body within 100 feet of construction area
  - (7) Total acreage of drainage area and direction of flow for any water body within 100 feet of construction area.
  - (8) Delineation of forested areas
  - (9) Identification of environmentally sensitive areas such as Chesapeake Bay Critical Areas, Class I and Class IV streams, parklands, steep slopes, historical sites, archaeological sites, rural and rustic roads, etc.
  - (10) Supporting documentation: i.e., County and/or Soil Conservation District approved sediment control plans
- b) Comply with the requirements and procedures set forth by the Maryland Department of the Environment (MDE), latest edition of the Maryland Standards and Specifications for Soil Erosion and Sediment Control and Water Resources Administration (WRA), latest edition of the Maryland Guideline to Waterway Construction, with specific jurisdiction requirements as modified in this section, and the Specifications and Standard Details.
  - c) The soil erosion and sediment control strategy that is formulated on the drawings is to be conveyed to the contractor through the sediment control devices shown on the drawings and in the Standard Details.
  - d) All drawings must be easy to read and interpret if they are to be implemented correctly. To help clarify and simplify the drawings, standard symbols have been developed and are used to facilitate the understanding and review of the drawings. The symbols should be bold and easily discernible on the drawings.
- 3) The WSSC is the approving agency for the Erosion and Sediment Control Permit and drawings for erosion and sediment control.
  - 4) The WSSC will provide its comments for erosion and sediment control on the drawings and also provide a Plan Review Checklist. In addition, see the following Environment Review Checklist. Refer to the checklist for the type of information required on the drawings, when applicable.



ENVIRONMENTAL REVIEW CHECKLIST

CONTRACT NUMBER \_\_\_\_\_ TO: \_\_\_\_\_  
 DATE: \_\_\_\_\_ REVIEWER: \_\_\_\_\_

- SEDIMENT CONTROL APPROVAL STICKER ENCLOSED.
- RETURN ONE COPY OF APPROVED PLAN.
- RETURN UTILITY SEDIMENT CONTROL PERMIT WITH TOP PORTION FILLED OUT.
- SEDIMENT CONTROL NEEDED.
- DEVELOPER'S SEDIMENT CONTROLS NEEDS TO BE SHOWN.
- RESUBMIT WITH COUNTY APPROVED SEDIMENT CONTROL PLAN.
- RESUBMIT WITH APPROVED FOREST CONSERVATION PLAN.
- ADD NOTE TO PROTECT STOCKPILE AREAS.
- ADD NOTE TO NOTIFY WSSC AND COUNTY DEP WHEN WORKING THROUGH SEDIMENT TRAP.
- CHANGE RESTORATION SCHEDULE AS NOTED ON PLAN.
- SHOW 100 YEAR FLOOD PLAIN ELEVATION AND DELINEATION.
- SHOW WETLAND DELINEATION AND BUFFER ON PLAN.
- SHOW DRAINAGE AREA AT STREAM CROSSING.
- STREAM CROSSING, STREAM DIVISION, DEWATERING NOTED NEEDED.
- LOCATION OF STREAM CROSSING SHOULD BE CHANGED (SEE PLAN).
- CHANGE SIZE OF RIPRAP (SEE NOTES ON PLAN).
- SHOW CROSS SECTIONAL AREA OF STREAM CHANNEL AT CROSSING.
- PROJECT IMPACTS NON-TIDAL WETLANDS OF SPECIAL STATE CONCERNS.
- ADD THIS NOTE TO PLAN: CALL JIM BENTON WHEN JOB IS COMPLETED FOR TREE PLANTING AT 301-206-8077
- ADD THIS NOTE TO PLAN: 48 HOURS ADVANCE NOTICE IS REQUIRED PRIOR TO UTILITY CONSTRUCTION AT 301-206-8077.
- ADD THIS NOTE TO PLAN: A PRE-CONSTRUCTION MEETING IS REQUIRED WITH 48 HOURS ADVANCE NOTICE AT 301-206-8077. THE UTILITY SEDIMENT CONTROL PERMIT WILL BE ISSUED TO THE CONTRACTOR AT THIS MEETING.
- ADD THIS NOTE TO PLAN: ALL UTILITY INSTALLATION MUST BE IN CONFORMANCE WITH THE CONDITIONS OF THE SOIL CONSERVATION DISTRICT/COUNTY APPROVED SEDIMENT CONTROL PLAN NO. \_\_\_\_\_.
- ADD THIS NOTE TO PLAN: UTILITY SEDIMENT CONTROL APPROVAL IS CONTINGENT UPON APPROVED COUNTY SEDIMENT CONTROL PLAN.
- SEE ADDITIONAL NOTES ON PLANS.

PERMITS REQUIRED

- |                                   |                               |   |
|-----------------------------------|-------------------------------|---|
| NOT REQ. <input type="checkbox"/> | REQ. <input type="checkbox"/> | 1. UTILITY SEDIMENT CONTROL PERMIT.                             |
| NOT REQ. <input type="checkbox"/> | REQ. <input type="checkbox"/> | 2. PUBLIC TREE PERMIT. <input type="checkbox"/> REFERRED TO DNR |
| NOT REQ. <input type="checkbox"/> | REQ. <input type="checkbox"/> | 3. TIDAL WETLAND PERMIT.  |
| NOT REQ. <input type="checkbox"/> | REQ. <input type="checkbox"/> | 4. NON-TIDAL WETLAND PERMIT.                                    |
| NOT REQ. <input type="checkbox"/> | REQ. <input type="checkbox"/> | 5. CRITICAL AREA APPROVAL.                                      |
| NOT REQ. <input type="checkbox"/> | REQ. <input type="checkbox"/> | 6. FSD/FCP.   |

---



---



---



---



---



**c. Design Requirements.**

- 1) Sediment control design must conform to the latest edition of the Maryland Standards and Specifications for Soil Erosion and Sediment Control, Specifications and Standard Details.
- 2) Sensitive areas. Include but may not be limited to the following; Chesapeake Bay Critical Areas, Tidal and Non-Tidal Wetlands, Areas of Special State Concerns, any Park Property, Streams, especially Class III and Class IV, Steep Slopes, Historical Sites, Archaeological Sites, Forested Areas, Water Shed Areas (serving water supply reservoirs), and Designated Rural and Rustic Roads.
  - a) The sensitive nature of these areas within or adjacent to Prince George's and Montgomery counties and within the State of Maryland in general needs to be considered when the sediment control and erosion strategy are prepared.
  - b) Additional soil erosion and sediment control provisions and measures may be required to protect these areas to the greatest extent possible.
- 3) Existing areas and developments.
  - a) Show all existing and proposed sediment control devices on the drawings.
  - b) Sediment control devices must be within the limits of the contract and within the WSSC right of way and construction strips or public road right of way to accommodate the proposed construction.
  - c) Show existing elevation contours at two (2) foot intervals on the drawings, when the design is not within the road right of way.
  - d) When crossing a stream or drainage ditch, show the amount of drainage area upstream of the point of the crossing on the drawings.

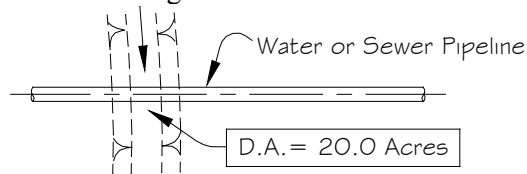

- 4) Proposed developments.
  - a) When the proposed pipeline is within a proposed development, show the erosion and sediment control requirements of the developer's sediment control plan on the drawings and label as existing. The sediment control permit number must be noted in the General Notes.
  - b) Additional devices may be required if the limit of the design falls outside the limits of the site sediment control. Design additional devices and show them on the drawings, see procedures above.



5) WSSC facility contracts.

- a) Provide the design of the sediment control devices on a separate soil erosion and sediment control plan.
- b) Obtain approval from the following authorities.
  - (1) For underground pipelines, conduits, etc., approval is obtained through the WSSC, see procedures noted above.
  - (2) For site clearing, grading and building, obtain a permit through the MDE, unless otherwise noted.
- c) Request any additional sediment control requirements from WSSC.

**d. Sediment Control Devices.**

(All Sediment Control Devices shown on a plan should be labeled "Install" or "Existing")

**1) Silt Fence.** A silt filtering device, see Standard Detail SC/1.0.

- a) A silt fence is a temporary barrier of woven fabric used to intercept surface runoff from disturbed areas.
- b) Silt fences can be used to intercept sheet flow only and cannot be used as a velocity check in ditches or swales or placed where they will intercept concentrated flow.
- c) Silt fences cannot be used where rocky soils and paved areas prevent the keying in of the fabric.
- d) Design criteria, show the limits of the silt fence on the drawings as follows:
  - (1) Design calculations are not required.
  - (2) Design all silt fences as close to the same contour grade line as possible.
  - (3) The area below the silt fence must be undisturbed or stabilized.
  - (4) Determine the slope/grade and slope length entering the silt fence, and the total length of silt fence. To determine the above, refer to the tables and charts in the latest edition of the Maryland Standards and Specifications for Soil Erosion and Sediment Control.
  - (5) Show silt fences on the drawings using this symbol.

— SF —



2) **Silt Fence on Pavement:** A silt filtering device, see Standard Detail SC/1.1

- a) A silt fence is a temporary barrier of woven fabric used to intercept surface runoff from disturbed areas.
- b) To intercept sediment-laden sheet flow allowing the deposition of sediment transported from upslope. Silt fence is not to be used where it will intercept concentrate flow.
- c) Silt fence on pavement is limited to intercepting sheet flow from small disturbed areas when standard silt fence cannot be used. The use of silt fence on pavement is based on slope length and steepness of the contributing drainage areas.
- d) Design criteria; show the limits of the silt fence on pavement on the drawings as follows:
  - (1) Silt fence on pavement design constraints.

Average Slope Steepness	Maximum Slope Length	Maximum Silt Fence Length
Flatter than 50:1 (<2%)	250 feet	500 feet
50:1 to 10:1 (2-10%)	125 feet	250 feet
10:1 to 5:1 (>10-20%)	100 feet	200 feet

- (2) Silt fence on pavement must be placed on the contour.
- (3) The use of Silt fence on pavement must conform to the design constraints listed in the above table.
- (4) Show silt fence on pavement on the drawings using this symbol.

|—— SF ——|

3) **Super Silt Fence.** A silt filtering device, see Standard Detail SC/2.0.

- a) A super silt fence is a temporary barrier of fabric over a chain link fence used to intercept sediment laden runoff from small disturbed areas.
- b) Super silt fences can be used where the installation of a dike would destroy sensitive areas, woods, wetlands, etc.
- c) Super silt fences provide a barrier that collects and holds debris and soil, preventing the material from entering critical areas, streams, streets, etc.
- d) Super silt fences can be used to intercept sheet flow only and cannot be used as a velocity



check in ditches or swales or placed where they will intercept concentrated flow.

- e) Super silt fences cannot be used where rocky soils and paved areas prevent the keying in of the fabric.
- f) Design criteria, show the limits of the super silt fence on the drawings as follows:
  - (1) Design calculations are not required.
  - (2) Design super silt fences as close to the same contour grade line as possible. No section of the super silt fence should exceed a grade of five (5%) percent for a distance of fifty (50) feet.
  - (3) Determine the slope/grade and slope length entering the super silt fence and the total length of super silt fence. To determine the above, refer to the tables and charts in the latest edition of the Maryland Standards and Specifications for Soil Erosion and Sediment Control.
  - (4) Show super silt fence on the drawings using this symbol.

— SSF —

- 4) **Stream Bank Protection at Utility Crossing.** Used as stream bank protection, see Standard Detail SC/3.0 and the design guidelines under Part Three, Section 9 (Pipeline Stream Crossings). On the drawings, show stream bank protection at utility stream crossings using this symbol.

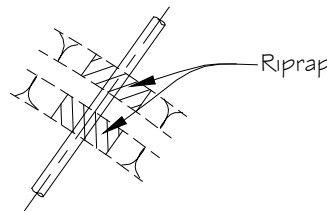

- 4) **Stream Invert Protection for Shallow Utility Stream Crossings.** Used as stream invert protection for shallow utility stream crossings, see Standard Detail SC/3.1 and the design guidelines under Part Three, Section 9 (Pipeline Stream Crossings). On the drawings, show stream invert protection on the drawings using this symbol.

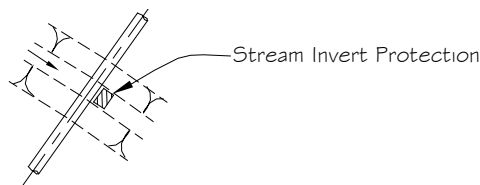

- 6) **Sediment Traps.** A temporary sediment trapping device formed by excavation or an



embankment with an approved outlet used to intercept sediment laden runoff and to retain the sediment.

- a) Design the sediment trap at the point(s) of discharge from the disturbed area.
- b) Two (2) types of sediment traps.
  - (1) Riprap Outlet Sediment Trap, used as a sediment trapping device, see Standard Detail SC/4.0. The outlet for this trap consists of a partially excavated channel lined with riprap.
  - (2) Stone Outlet Sediment Trap, used as a sediment trapping device, see Standard Detail SC/5.0. The outlet for this trap is over a stone section placed on level ground.
- c) Design criteria.
  - (1) Provide calculations showing that the design meets the criteria that are set forth in this section and the latest edition of the Maryland Standards and Specifications for Soil Erosion and Sediment Control.
  - (2) Design sediment traps to have storage of 3600 cubic feet per acre of contributory drainage. For sizing the sediment trap, refer to the latest edition of the Maryland Standards and Specifications for Soil Erosion and Sediment Control.
  - (3) Design of the outlet structure for the sediment trap. Channels the discharge water into a stabilized area or a stable watercourse. Indicate the drainage area for the riprap outlet sediment trap on the drawings. Two (2) types of outlets are:
    - (a) Riprap outlet sediment trap, see Standard Detail SC/4.0. This type of trap may be used for drainage areas of up to a maximum of ten (10) acres.
    - (b) Stone outlet sediment trap, see Standard Detail SC/5.0. This type of trap may be used for drainage areas of up to a maximum of five (5) acres, unless a riprap channel in addition to the stone outlet is provided. The addition of the riprap channel will allow the trap to be used up to a maximum drainage area to ten (10) acres.
  - (4) Provide the following information on the sediment control plan.
    - (a) Delineate each trap on the contract drawings in such a manner that it will not be confused with any other features.
    - (b) Indicate all necessary information to properly construct and maintain the trap.
    - (c) Show the following information for each trap: trap number, type of trap, drainage area, storage required, storage provided, outlet length, storage depth below outlet and cleanout elevation, embankment height and elevation (if applicable), typical detail of each trap, trap bottom and crest elevations, and the following information for the outlet structure:

[1] Riprap outlet, using Standard Detail SC/4.0, provide dimensions on the drawings for the





bottom width of the weir (b) and the minimum depth of channel (a). For sizing the riprap outlet sediment trap [dimensions (a) and (b)], and other information, refer to the latest edition of the Maryland Standards and Specifications for Soil Erosion and Sediment Control. Show the riprap outlet sediment trap on the drawings using this symbol.

ROST

[2] Stone outlet, using Standard Detail SC/5.0, indicate the dimensions on the drawings for the bottom width of the weir and the elevation for the outlet crest (top of stone in weir section). The minimum length of weir (feet) of the outlet is to be equal to four (4) times the drainage area (acres). Design the outlet crest elevation to be level and at least one (1) foot below the top of the embankment and no more than three (3) feet above ground beneath the outlet, see Standard Detail SC/5.0. For addition information on the stone outlet sediment trap, refer to the latest edition of the Maryland Standards and Specifications for Soil Erosion and Sediment Control. Show stone outlet sediment trap on the drawings using this symbol.

SOST

- 7) **Stone Outlet Structure**, used as a sediment filtering device, see Standard Detail SC/6.0.
- a) A stone outlet structure is a temporary stone dike installed in conjunction with and part of an earth dike.
  - b) The purpose of the stone outlet structure is to filter sediment laden runoff and to provide a protection outlet for an earth dike, to provide for concentrated flow and to allow the area behind the dike to dewater.
  - c) Design criteria, show stone outlet structure on the drawings as follows.
    - (1) Provide calculations showing that the design meets the criteria that are set forth in this section and the latest edition of the Maryland Standards and Specifications for Soil Erosion and Sediment Control.
    - (2) Design a stone outlet structure to discharge onto an already stabilized area or into a stable watercourse. Stabilization consists of complete vegetative cover, paving, etc., sufficiently established to be erosion resistant.
    - (3) Design stone outlet structure for drainage areas less than 1/2 acre or less. Indicate the drainage area for the stone outlet structure on the drawings.
    - (4) Verify that the minimum length of the crest of the stone outlet structure will work in the location shown.
    - (5) Provide the elevation of the crest of the stone dike on the drawings. The crest of the stone dike is to be at least 6" lower than the lowest elevation of the top of the earth dike.
    - (6) The stone outlet structure can have the optional baffle board installed, if so, the drawings will have to note this.



(7) For additional information, see Standard Detail SC/6.0 and refer to the latest edition of the Maryland Standards and Specifications for Soil Erosion and Sediment Control.

(8) Show the stone outlet structure on the drawings using this symbol.



**8) Stabilized Construction Entrance**, used to reduce tracking of sediment onto streets or public right of ways, see Standard Detail SC/7.0.

a) Stabilized construction entrances reduce tracking of sediment onto streets or public right of ways and provide a stable area for entrance or exit from the construction site.

b) Stabilized construction entrances should not be used on existing paving.

c) Design criteria, show the stabilized construction entrance on the drawings as follows.

(1) Design calculations are not required.

(2) Verify that the minimum length and width of the stabilized construction entrance will work at the location shown on the drawings. Provide fifty (50) feet minimum length and ten (10) feet minimum width, with a flared section at the existing paving for a turning radius.

(3) Design piping under the stabilized construction entrance if necessary to maintain positive drainage. See Standard Detail SC/7.0 and the latest edition of the Maryland Standards and Specifications for Soil Erosion and Sediment Control for "Stabilized Construction Entrance".

(4) For additional information, refer to the latest edition of the Maryland Standards and Specifications for Soil Erosion and Sediment Control for "Stabilized Construction Entrance".

(5) Show the stabilized construction entrance on the drawings using this symbol.



**9) Earth Dikes**, used as a water handling device, see Standard Detail SC/8.0.

a) Earth dikes are a temporary berm or ridge of soil, compacted, stabilized and located in a manner as to direct water to a desired location.

b) Design criteria, show earth dike on the drawings as follows.

(1) Provide calculations showing that the design meets the criteria that are set forth in this section and the latest edition of the Maryland Standards and Specifications for Soil Erosion and Sediment Control.

(2) Determine the drainage area that is entering and being intercepted by the earth dike, and the



slope along the earth dike.

- (3) Using the above drainage area and slope, determine the type of dike (either A or B) and the type of lining (either 1, 2, 3 or 4). Refer to the tables and charts in the latest edition of the Maryland Standards and Specifications for Soil Erosion and Sediment Control.
- (4) Show the earth dike type (A or B) and lining (1, 2, 3 or 4) on the drawings using this symbol.

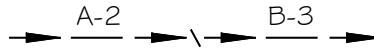

Note: The letter indicates the type of dike and the number indicates the lining type.

- (5) The design may preempt the use of the design criteria for the selection of the type of dike and lining type, if the design uses the basic requirements set forth in the latest edition of the Maryland Standards and Specifications for Soil Erosion and Sediment Control for Earth Dike and provide calculations.
- (6) Earth dike outlet design.
  - (a) The flow of water from the earth dike must discharge into an outlet that functions without causing erosion.
  - (b) Run-off from the disturbed areas is to be conveyed to a sediment trapping device until the drainage area above the earth dike is adequately stabilized.
  - (c) Clear water diversions around the disturbed areas are to be discharged into an undisturbed, stabilized area or watercourse at a non-erosive velocity.
- 10) Temporary Access and Pipeline Waterway Crossing.** The type of crossing will be at the option of the contractor, unless otherwise noted on the drawings or specified by other agencies.
  - a) Provide a note on the drawings that a temporary access waterway crossing will be required at the waterway crossing and indicate the type of temporary access waterway crossing.
  - b) Types of temporary access waterway crossings for the purpose of providing a safe access across a waterway for construction equipment are: Temporary Access Bridge, see Standard Detail SC/11.0, and Temporary Access Culvert, see Standard Detail SC/12.0. For additional information, see Specifications, the latest edition of the Maryland Standards and Specifications for Soil Erosion and Sediment Control and the latest edition of the Maryland Guidelines to Waterway Construction.
  - c) Types of temporary pipeline waterway crossings for the purpose of providing erosion control when constructing a pipeline crossing a stream are as follows:
    - (1) Open Diversion. For additional information, see Specifications, Standard Detail SC/13.0, and the latest edition of the Maryland Guidelines to Waterway Construction for "Sandbag/Stone Flow Diversion".
    - (2) Culvert Diversion. For additional information, see Specifications, Standard Detail SC/14.0, and the latest edition of the Maryland Guidelines to Waterway Construction for "Culvert



Pipe with Access Road".

- (3) Diversion Pipe. A pipe that is placed between two (2) sandbag/stone diversions and the pipe diverts the flow around the construction area in the stream. For additional information, see the latest edition of the Maryland Guidelines to Waterway Construction.
  - (4) Pump Around Diversion. This type is similar to the pipe diversions, except a pump is placed upstream behind a sand bag dam and the stream water is pumped around the construction area, see WSSC Standard Detail SC/10.0. For additional information, see the latest edition of the Maryland Guidelines to Waterway Construction for "Pipe Diversion" and the latest edition of the Maryland Standards and Specifications for Soil Erosion and Sediment Control for "Removable Pumping Station and Sump Pit".
  - (5) Fabric-base Channel Diversion. A temporary channel that is constructed around the construction area within the stream. The stream is then diverted into the fabric-base channel using two (2) sandbag diversions. For additional information, see the latest edition of the Maryland Guidelines to Waterway Construction.
- d) Design criteria.
- (1) Design calculations are not required, unless WSSC requires one type of temporary access or pipeline crossing. In this case, provide calculations showing that the design meets the criteria that is set forth in this section and the latest edition of the Maryland Standards and Specifications for Soil Erosion and Sediment Control and the latest edition of the Maryland Guidelines to Waterway Construction.
  - (2) Show the drainage area and cross-sectional area at the point of the crossing.
  - (3) Size the temporary access culvert and culvert diversions in accordance with Specifications and the latest edition of the Maryland Standards and Specifications for Soil Erosion and Sediment Control.
  - (4) For additional information refer to the latest edition of the Maryland Standards and Specifications for Soil Erosion and Sediment Control for Temporary Access Waterway Crossings.

**11) Sediment Tank for Dewatering**, used as a dewatering device and is contractor requirement.

- a) A sediment tank for dewatering is a compartment tank container through which sediment laden water is pumped to trap and retain the sediment.
  - c) Design criteria. Provide calculations showing that the design meets the criteria set forth in this section and the latest edition of the Maryland Standards and Specifications for Soil Erosion and Sediment for "Desilting Structure for Dewatering". For additional information refer to the latest edition of the Maryland Standards and Specifications for Soil Erosion and Sediment Control for "Sediment Tanks".
- 12) Curb Inlet Protection**, used as a filtering device and a barrier across or around a storm drain inlet to intercept and filter sediment laden runoff before it enters the storm drain system. Storm



drain inlet protection may take various forms, depending upon the type of inlet to be protected.

- a) Provide storm drain inlet protection, when the drainage area to the inlet is disturbed and the following conditions prevail.
  - (1) It is not possible to temporarily divert the storm drain outfall into a sediment trapping device.
  - (2) Watertight blocking of the inlet is not advisable.
  - (3) Drainage area is less than 1/4 acre for curb inlet protection.
- d) For curb inlet protection, see Standard Detail SC/16.0, and show it on the drawings using this symbol.



- c) If other types of inlet protection are required, provide all details and notes for the protection of the storm drain inlet on the drawings.
- d) For additional information, refer to the latest edition of the Maryland Standards and Specifications for Soil Erosion and Sediment Control.

**13) At –Grade Inlet Protection** used as a filtering device and a barrier across or around a storm drain inlet to intercept and filter sediment laden runoff before it enters the storm drain system. Storm drain inlet protection may take various forms, depending upon the type of inlet to be protected.

- a) Provide storm drain inlet protection, when the drainage area to the inlet is disturbed and the following conditions prevail.
  - (1) It is not possible to temporarily divert the storm drain outfall into a sediment trapping device.
  - (2) Watertight blocking of the inlet is not advisable.
  - (3) Drainage area is less than one (1) acre for curb inlet protection.
- e) For curb inlet protection, see Standard Detail SC/16.1, and show it on the drawings using this symbol.



**14) Filter Bag:** A geotextile bag through which sediment-laden water is pumped.



- a) Filter sediment-laden water prior to discharge.
- b) When dewatering is needed in association with excavations. Trenches and sediment traps.

**15) Filter Log:** A temporary, tubular casing filled with compost filter media.

- a) To intercept sheet flow, retain sediment and filter runoff through the log media.
- b) Filter logs are an alternative to silt fence, and can be used in hand to reached areas, on frozen ground and pavement, and near tree roots.
- c) Design criteria:
  - (1) Filter logs design constraints.

Log Diameter	8" to 15 inches	>15 to 24 inches
Average Slope	Maximum Slope Length	
Flatter than 50:1 (<2%)	125 feet	250 feet
50:1 to 10:1 (2-10%)	65 feet	125 feet
<10:1 to 5:1 (>10-20%)	50 feet	100 feet
<5:1 to 2:1 (>20-50%)	NA	50 feet

- d) Filter Logs must be placed on the contour with ends turned up grade to prevent by-pass.
- e) Can only be used with sheet flow.
- f) Filter logs must be used in accordance with the design constraints above table.
- g) See Standard Detail SC/20.0 and SC/20.1.

**e. Tree Protection.**

- 1) Tree protection is a way to protect desirable trees from mechanical and other injury while the contractor installs the pipeline, etc.
- 2) Label on the drawings the size and type of all trees 6-inch and larger within fifty (50) feet of working area limits.
- 3) When to use tree protection. If the construction area is within the dripline of any tree, it will require tree protection and if the contractor does not have the right to cut trees within the WSSC construction strip, see the Part Three, Section 2 (Rights of Way and Construction Strips).



- 4) For additional information, see Standard Details SC/17.0, SC/18.0, and SC/19.0, and the latest edition of the Maryland Standards and Specifications for Soil Erosion and Sediment Control.
- 5) When referring to Standard Detail SC/19.0, show this symbol on the drawings.



## 9. Pipeline Stream Crossings.

### a. General.

- 1) In most cases stream bank stabilization for pipelines crossing streams can be accomplished using Standard Detail SC/3.0 however, see if this Standard Detail is applicable by considering the following guidelines in this section: Selection of Crossing Alignments, Data Collection, Estimate of Stream Design Flow, and Determination of Cover Depth.
- 2) Calculations are presented in this section to provide examples of the types of analysis required at a minimum. They are not intended to be used as a step by step procedure for stream crossing design. Exercise professional judgment and perform the necessary analysis required for the particular design.
- 3) General guidelines for cases that may require a more in depth evaluation of instability are presented in Special Considerations, in this section.
- 4) For selection of pipe material, see Part One, Section 2 (Pipe Materials and Fittings) for water pipelines and Part Two, Section 2 (Pipeline Sizes and Materials (Gravity Sewer)) for sewer pipelines and for general vertical alignment requirements for pipeline crossings at streams, see Part One, Section 11 (Vertical Alignment, Profiles) for water pipelines and Part Two, Section 8 (Vertical Alignment, Profiles) for sewer pipelines.

### b. Selection of Crossing Alignment.

- 1) Base the selection of the crossing alignment primarily on the consideration of channel stability and environmental and regulatory compliance.
- 2) Minimize the number of crossings, the total length of the crossing, and the disturbed area. Try to select an alignment that is perpendicular to the stream flow.
- 3) Determine requirements and constraints set forth by agencies having jurisdiction over the area of the crossing alignment. Such agencies may include Maryland National Capital Park & Planning Commission (MNCPPC), Maryland Department of the Environment (MDE) and the Army Corps of Engineers.
- 4) Identify existing and potential long term channel instability problems at the alignment location, by the use of available topographic maps, land use information and field investigation. Channel instability can lead to failure/erosion of channel banks, shifting of channel positions and channel bed erosion.
- 5) Selecting stream crossing locations. Avoid locations with severe channel instability problems. Crossing alignments may be strategically located to minimize the adverse effects of channel instability. The following are guidelines for selecting locations of stream crossings.
  - a) At meandering channel bends, stream flow velocities can severely erode channel banks and scour holes on the channel bottom. The crossing can be placed approximately midway between two adjacent meandering bends or upstream of the meandering bend.





- b) Abrupt drop in channel bed, flow depth, riffles or localized scour holes indicate existing or potential channel bed instability. Alignment should not be placed in close proximity to and **not** downstream of these locations.
- c) Where flow constriction occurs, e.g., due to bridge construction or channelization, the crossing should be placed upstream of the location of flow constriction, if possible.
- d) Stream channels which show noticeable increase in channel widths, meandering, steeply sloped channel banks, and lack of vegetation, indicate existing or potential problems of channel widening and changes in channel position. If the pipeline alignment parallels the stream channel, provide a buffer width between the nearest channel bank and the limit of disturbance. Determine the buffer width on a case by case basis. The minimum buffer width required by the State of Maryland, Department of Natural Resources, is twenty five (25) feet from the limit of construction area to the top of the nearest of stream bank.
- e) Sediment traps and storm water control ponds can drastically reduce sediment supply and increase channel bed and bank erosion in downstream channels. Pipeline crossings should not be placed in close proximity downstream of these structures, if possible.
- f) Activities such as channel dredging or cleaning can cause channel bed erosion due to decrease in flow depth and increases in flow velocity. Pipeline crossings should not be placed in close proximity upstream of these activities.
- g) Alteration in stream flow path/direction by others, due to construction activities and channel work, can drastically affect stream hydraulics. Pipeline crossings should not be placed in close proximity upstream or downstream of these locations.
- h) Select the crossing alignment such that the pipeline will be protected from impacts of construction of other utilities or structures.
- i) Select the vertical alignment of gravity sewer to avoid the use of an inverted siphon.

**c. Data Collection.**

- 1) Recommended data/information collection requirements are as follows:
  - a) Topographic contour map of the stream channel and drainage area at the location of stream crossing.
  - b) From field surveys determine the existing channel elevation, dimensions (depth, width), cross-sectional profile, longitudinal profile, channel bank and bed slopes with sufficient detail to define the channel conditions.
  - c) Soil samples of channel bed materials for grain size distribution analysis, for pipeline sizes 12-inch and smaller diameter soil samples are not required.

**d. Estimate of Stream Design Flow.**



- 1) Determine the estimated stream design flow for pipeline crossings larger than 12-inch diameter as follows, for pipelines 12-inch and smaller, it is not necessary to estimate the stream design flow. Stabilization of channel banks and determination of cover depth should be done for the design flow, which is defined as 1.2 times the existing Mean Annual Flood (MAF). The MAF represents a flood having a return period of approximately one (1) to two (2) years and can be assumed to be associated with the existing bankfull flood stage. This may be obtained from published hydrologic study reports. It can also be estimated by applying Manning's equation to a representative channel cross section and channel slope. For example calculations, see Design Examples in this section. The 1.2 factor applied to the MAF is intended to account for future increase in flow due to land use changes in the watershed. If more than one crossing is located at various segments of the same stream, assure consistency in the defined design flow magnitude.

**e. Determination of Cover Depth.**

- 1) The design for the pipeline cover depth below the existing stream bed is to be determined after considering the factors below, which include the minimum required depth of cover, protection against frost penetration, pipe flotation and channel bed erosion. Measure the cover depth from the lowest point in the channel bed to the top of the pipe and show the required depth on the pipe profile.
  - a) For the minimum cover depth. For water pipelines, see Part One, Section 11 (Vertical Alignment (Profiles)) and for sewer pipelines, see Part Two, Section 9 (Vertical Alignment (Profiles)). The cover depth must be greater than the minimum cover depth.
  - b) Protection against frost penetration. Frost protection will be attained by providing the minimum cover depth as stated above. Due to a higher fluid temperature in the sewer pipeline, frost penetration generally may not be a problem for sewer pipelines crossing streams.
  - c) Protection against flotation. Check for pipe flotation and determine the required cover depth, see requirements for evaluating the possibility of pipe flotation, Part Three, Section 4, and (Buoyancy of Pipelines). If the cover depth is not adequate to protect against the potential of pipe flotation, provide a special design, see Preventive Procedures under Part Three, Section 4 (Buoyancy of Pipelines).
  - d) Protection against channel bed erosion.
    - (1) For pipelines 12-inch and smaller diameter. The required cover depth for protection against channel bed erosion may be assumed to be the same as the minimum cover depth as stated above. No calculation is required to estimate channel depth susceptibility to bottom erosion. However, calculations should be done to estimate this depth for cases where significant channel bottom erosion is anticipated due to stream channel configuration or other factors.
    - (2) For pipelines larger than 12" diameter. Protect the pipeline from exposure to direct stream flow and undermining of the channel bed beneath the pipeline due to erosion. Estimate the depth of soil cover above the pipeline that would be susceptible to erosion under the design flow according to the following procedure.
      - (a) Calculate a "new" channel depth at which the bed materials would theoretically be stable under the design flow. The difference between the new channel depth and the existing



channel depth will give the soil depth that is susceptible to erosion, and hence the required cover depth.

- (b) Calculations of the "new" channel depth can be based upon two approaches, namely the Tractive Force Method or the Permissible Velocity Method. Technical basis for these methods can be found in hydraulics textbooks and practice handbooks. The Tractive Force Method is not strictly applicable to channels with bed materials smaller than medium sand. For such channels, the Permissible Velocity Method can be applied. Examples of calculations, see Design Examples in this section. In order to properly apply these calculations methods, soil samples of channel bed material should be collected and analyzed for grain size distribution.
  - (c) Start the calculations with an estimate of stability of bottom material under the existing bankfull flow condition. If this shows that the bottom materials are stable, then no further calculation is needed.
  - (d) If the cover depth is shallower than the depth calculated for the protection against channel bed erosion using the above procedure, then provide special designs for protection against channel erosion as indicated below. Also verify that the depth of cover is adequate for protection against frost penetration and flotation. If the channel bed is not armored with erosion-resistant material, provide armoring of the channel bed downstream of the pipeline crossing, Standard Detail SC/3.1. (This Standard Detail is based on Maryland's Guidelines To Waterway Construction, January 1986, published by the former State of Maryland Water Resources Administration. For other methods of armoring the stream bed, see Maryland's Guidelines To Waterway Construction, January 1986.)
- 2) Submit the following data and information: Layout of crossing alignment on topographic maps of the stream valley with five (5) foot vertical contour intervals, results from gradation analysis of channel bed materials for pipelines larger than 12-inch diameter, existing channel dimensions, cross section profile, channel bank and bed slopes obtained from the field survey, environmental/regulatory compliance and constraints, and justification for the design of bank stabilization and cover depth with applicable calculations.

**f. Post Construction Stabilization of Channel Banks.**

- 1) Stabilize channel banks to provide protection against surficial erosion of bank materials, slope instability and lateral movements of stream channel at the location of the stream crossing.
  - a) Standard design. If the primary problem is surficial erosion and the maximum bankfull flow velocity is no greater than 10 feet per second (fps), provide riprap stabilization of channel banks, in accordance with Standard Detail SC/3.0. The maximum bankfull flow velocity can be estimated by applying Manning's Equation to a representative channel cross section and bottom slope. Provide calculations for maximum bankfull velocity estimation.
  - b) Special design. If certain field conditions are considered to be not entirely applicable to the Standard Design SC/3.0, consider alternative methods of channel bank stabilization, these may include modification to standard detail, use of geotextiles or vegetation, methods to reduce flow velocities, and/or directing flow path away from the banks. Provide calculations for maximum bankfull velocity estimation. The following conditions may require special design:



- (1) Stream channels where maximum bankfull flow velocity is greater than or much lower than 10 fps. Riprap stone sizes other than Class 2 as indicated on Standard Detail SC/3.0 may be required under these cases. Estimate the maximum bankfull flow velocity and specify the riprap stone size on the drawings.
- (2) Stream banks subject to potential risks of overall slope instability. Perform slope stability analysis and determine if such risks exist. Take a soil boring at the channel bank at a depth of at least three (3) feet below the proposed invert elevation of the pipe.
- (3) Channel banks that may be subject to direct impact of high flow velocities, or lateral movements, e.g., meandering channel bends or channel constrictions.
- (4) Channel banks with existing bank slopes much steeper than the maximum 2:1 (H:V) slope.

**g. Special Considerations.**

- 1) Stream crossing design can be done based on site specific conditions at the location of crossing. However, some cases may call for an evaluation of stream instability for a segment of the stream. Special considerations in alignment selection and in design for channel bank stabilization and pipeline cover depth may be needed. Consult with WSSC regarding the need, approach and method of investigation and design.
- 2) Examples of such cases are: Major pipelines aligned predominately parallel to the stream channel, but which may cross the stream at more than one location due to a highly meandering flow course with severe bank and bed erosion problems; major pipelines crossing streams having serious historical channel instability problems; and field conditions that require special designs, other than using the standard details, as stated in this section.
- 3) Additional work may involve investigation of historical changes in channel conditions e.g. meandering, channel depth and width. Special designs for channel bank stabilization and channel bed erosion protection may be needed, other than applying the standard detail. Consult with federal, state and local agencies regarding any riverine hydraulics and erosion studies which may have been done for a particular stream, or a stream segment. These agencies may include Federal Highway Administration, Army Corps of Engineers, Federal Emergency Management Agency, State Highway Administration, Park and Planning Commission and the County Department of Transportation.



**h. Calculations for Existing Mean Annual Flood and Existing Bankfull Flood Discharge.**

- 1) First, obtain from field surveys, representative existing channel dimensions (depth, top width, bottom width) and channel slope. The average channel slope can be checked against topographic maps available with five (5) foot contour intervals.
- 2) To determine Mean Annual Flood, apply Manning's Equation to the representative existing cross section:

$$Q_{\text{mean}} = (1.486/n) A R^{2/3} S_o^{1/2}$$

Where:

- $Q_{\text{mean}}$  = Mean Annual Flood, or bankfull flood discharge (cfs)
- $A$  = cross sectional area (sq. feet)
- $R$  = hydraulic radius in feet,  $R = A/P$
- $P$  = wetted perimeter (feet)
- $S_o$  = average slope of the water surface (ft/ft). It can be assumed to be the same as the channel slope under normal flow condition. The steepest slope should be used if the channel slope varies in the general vicinity of the crossing.
- $n$  = Manning's roughness coefficient

- (a) Exercise judgment when selecting an appropriate value for the Manning's coefficient. In general, the range of values shown in Table 22, may be used:

**TABLE "22"**  
Manning's Roughness Coefficient for Stream Channel Material

Stream Channel Material	Manning's Roughness Coefficient
Predominately cohesionless sandy/silty bed	$0.015 < n < 0.020$
Coarse sand, fine gravel to medium gravel	$0.02 < n < 0.03$
Coarse gravel	$n > 0.03$
Cobbles/shingles	$n > 0.04$

- (b) Streams with meanders, vegetative growth on the channel banks and irregularities in flow depths and flow paths can have higher Manning's coefficients than those listed above. Suggested Manning's coefficients for a variety of stream conditions can be found from the following references; Handbook of Hydraulics, by Brater & King, McGraw-Hill Book Company and Open Channel Hydraulics, Vente Chow, McGraw-Hill Book Company
- 3) To determine design flood ( $Q_{\text{design}}$ ), multiply the existing Mean Annual Flood (MAF) by 1.2. The magnitude of MAF is considered the same as the bankfull flood.



**Example Number 1.**

Assume:

channel width = 10 feet                      flow depth = 4 feet  
 channel bed slope = 0.001 ft/ft            channel materials mainly of medium/coarse sand

To determine  $Q_{\text{mean}}$ , apply Manning equation.  $Q_{\text{mean}} = (1.486/n) A R^{2/3} S_o^{1/2}$ 

Where

A = area                      P = wetted perimeter                      R = hydraulic radius  
 A = 40 feet<sup>2</sup>                      = 2d + w                                      = A/P  
 P = 18 feet                      R = 2.222 feet

Assume Manning coefficient, From Table "22",  $n = 0.02$  (for medium sandy materials).

$$Q_{\text{mean}} = (1.486/0.02) (40) (2.222)^{2/3} (0.001)^{1/2}$$

$$Q_{\text{mean}} = \underline{160 \text{ cfs}}$$

Bankfull Flood Velocity is therefore = 4.0 fps

$$V = Q_{\text{mean}} \div A$$

$$= 160 \text{ ft}^3/\text{s} \div 40 \text{ ft}^2$$

$$V = 4 \text{ fps}$$

Design flood,

$$Q_{\text{design}} = 1.2 Q_{\text{mean}}$$

$$= 1.2 (160 \text{ cfs})$$

$$Q_{\text{design}} = \underline{192 \text{ cfs}}$$

**i. Calculations for the Required Cover Depth for Protection Against Channel Bed Erosion.**

1) Tractive Force Method, use the following equations for calculations:

$$\tau_s = W R S$$

Where:

 $\tau_s$  = shear force of flowing water that will move the bed materials (lb/ft<sup>2</sup>)

R = hydraulic radius of the stream channel (feet)

S = channel slope (ft/ft). The steepest slope should be used if the channel slope varies in the general vicinity of the crossing.

W = unit weight of water (lb/ft<sup>3</sup>)

$$\tau_c = 0.05 W(S_s - 1) d$$

Where:

 $\tau_c$  = critical shear required to move the bed materials (lb/ft<sup>2</sup>) $S_s$  = specific weight of the bed materials  $S_s$  is usually assumed to be 2.65

d = representative grain size of the bed materials (ft)

Manning equation.  $Q = (1.486/n) A R^{2/3} S_o^{1/2}$ If  $\tau_s > \tau_c$ . Bed particle is considered unstable.If  $\tau_s \leq \tau_c$ . Bed particle is considered stable.

**Example Number 2 - Using the Tractive Force Method.**

Assume:

channel width	=	10 feet.	hydraulic radius	R	=	A/P
channel depth	=	5 feet.			=	10 x 50/20
slope	=	0.00075 ft/ft.		R	=	2.5 feet

From grain size analysis, the median size is coarse sand,  $d = 0.005$  feet (1.5mm).

Assume Manning's coefficient, from Table "22",  $n = 0.022$  for coarse sand

Therefore:  $Q_{\text{mean}} = 170$  cfs  $Q_{\text{design}} = 1.2 Q_{\text{mean}}$   
 $= 200$  cfs

Check critical shear.  $\tau_c = 0.050 \times 62.4 \times (2.65 - 1) \times 0.005 = 0.026$  lb/ft<sup>2</sup>  
 $\tau_s = 62.4 \times (2.5) \times (0.00075) = 0.117$  lb/ft<sup>2</sup>

Therefore:  $\tau_s > \tau_c$ . Bed particle is considered unstable.

Assume: A new channel depth, due to channel bed erosion by  $Q_{\text{design}}$ .  
 Assuming 7.0 feet of soil being eroded under  $Q_{\text{design}}$ .

Therefore:

new channel depth	=	12.0 feet	width remains at 10 feet
new area	=	120 feet.	new hydraulic radius $R_{\text{new}} = 3.5294$ feet

Calculate new slope.  $S_{\text{new}}$  by Manning's equation.

$$Q_{\text{design}} = 1.486/n (A_{\text{new}}) (R_{\text{new}})^{2/3} (S_{\text{new}})^{1/2}$$

Therefore:  $S_{\text{new}} = 0.000113$  ft/ft

Check:  $\tau_s = W R_{\text{new}} S_{\text{new}}$   
 $= (62.4) (3.5294) (0.000113)$   
 $\tau_s = 0.025$  lb/ft<sup>2</sup> <  $\tau_c$

Therefore: Required cover depth = 7.0 feet.

2) Permissible Velocity Method, use the following equation for calculations:

- a) This method can be applied to channels with relatively fine materials, preferably in the range of sand to fine gravel sizes. Perform soil sampling of channel bed materials and determine the representative grain size of the bed material and type of bed materials.
- b) Define the permissible velocity  $V$ , for the type of bed materials, see Table 23.
- c) Apply the following equations:  
 Manning's Equation  $Q = (1.486/n) A R^{2/3} S^{1/2}$



Continuity equation  $Q = V A$

Where:

$V$  = average channel velocity (ft/s)

$Q$  = discharge, rate of flow (ft<sup>3</sup>/s)

$A$  = cross-sectional flow area (ft<sup>2</sup>)

**TABLE "23"**  
Permissible Velocities for Stream Channel Material

Stream Channel Material	Permissible Velocities (V)
Sandy silt or cohesive silty clay, disturbed during construction	1.5 to 2.0 fps
Cohesionless fine to medium sand	Less than 1.5 fps
Coarse sand	1.5 to 2.0 fps
Coarse sand to fine gravel	2.0 to 2.5 fps
Fine to medium gravel	2.5 to 3.0 fps

**Example Number 3, using Permissible Velocity Method.**

Assume the same channel dimensions as in Example Number 2.

Calculate the average velocity for existing Mean Annual Flood by Manning's equation.

$$V = 1.486/0.022 \times (2.5)^{2/3} \times (0.00075)^{1/2}$$

$$V = 3.4 \text{ ft/s}$$

It is noted that 3.4 ft/s exceeds the permissible velocity of the coarse sandy material, which can be assumed at 1.8 ft/s average.

Therefore:

We need to assume new channel dimensions, under  $Q_{\text{design}}$ .

By the same approach as employed in Example Number 2 assume new channel depth at 12.0 feet, 5.0 feet plus 7.0 feet of eroded soil depth.

Estimate new channel slope,  $S_{\text{new}}$ , then calculate new flow velocity:

$$\begin{aligned} V_{\text{new}} &= 1.486/0.022 \times (R_{\text{new}})^{2/3} (S_{\text{new}})^{1/2} \\ &= 1.486/0.022 \times (3.5294)^{2/3} (0.000113)^{1/2} \end{aligned}$$

$$V_{\text{new}} = 1.7 \text{ ft/s}$$

Average velocity 1.7 ft/s is less than the permissible velocity, O.K.





## 10. Bridge Crossings.

### a. Conceptual Design.

- 1) **Making provisions for** a pipeline crossing on a bridge structure is considered a special design in every case due to the varied nature of bridge designs [AASHTO 1.9]. **The preferred concept of a pipeline bridge crossing will be the one minimizing structural and visual impact on the bridge and incorporating** straight alignment using either restrained mechanical joint DIP or butt welded steel pipe on a roller system with a pipe expansion joint which allows the pipeline to act independently of the bridge superstructure. This scenario is considered the ideal case because it is void of fittings and minimizes pipe joint deflections, which create thrust forces. However, due to the particular bridge **type and** configuration, other scenarios can be designed with approval. The **following** guidelines present design considerations that must be taken into account **for all proposed bridge crossings.**

### b. General.

- 1) Attaching pipelines (water, sewer, force main, etc.) to a bridge structure can materially affect the structure, the safe operation of traffic and the efficiency of the maintenance of the pipeline and the bridge. Attaching a pipeline to a bridge structure will not be considered unless the bridge structure is of a design that is adequate to support the additional load and any thrust of the pipeline.

Where it is feasible and reasonable to locate the pipeline elsewhere, attachments to bridge structures will not be approved by WSSC. To locate a pipeline on a bridge, demonstrate that the proposed pipeline on the bridge can be constructed, maintained and is more cost effective than a direct buried alignment. Consider in the design, the accessibility for inspection and maintenance of the pipeline on the bridge structure.

### c. Predesign Submittals and Approvals.

- 1) Submit the following information to the WSSC, to obtain conceptual approval to locate the proposed pipeline on the bridge prior to proceeding with the design:
  - a) A copy of the Bridge Authority's guidelines for attaching a pipeline on its bridge.
  - b) Preliminary design calculations for the pipeline on the bridge showing the additional load and any thrust on the bridge structure. Along with the calculations, provide **relevant bridge drawings (plans, sections, elevations, etc.) with pipeline** plan and profile sketches, information on the pipeline (size, proposed pipe material, etc.) and **scaled and dimensioned details** of the proposed means of supporting the pipeline.
  - c) Provide a statement describing alternative methods with relative cost estimates for constructing the pipeline around the bridge structure verse the cost of attaching the pipeline on the bridge.
  - d) Bridge Authority approval. Submit one of the following statements:
    - (1) Existing bridge structures. A letter from the Bridge Authority, stating that it has reviewed the conceptual design sketches/drawings and calculations and will allow the pipeline to be



attached to its structure.

- (2) Proposed bridge structures. A letter from the Bridge Authority and the bridge designer, stating that they have reviewed the conceptual design sketches/drawings and will allow the pipeline to be attached to their structure/ and also stating that the bridge structure will be designed for the additional pipe load.
- e) Right of Way Authority approval. Provide a letter from the authority whose right of way is being crossed by the bridge/pipeline, stating that its guidelines for having a pipeline being on a bridge above its property or jurisdiction are being complied with and that it approves of the crossing.

**d. Predesign Bridge Crossing Meeting.**

- 1) Due to the specialized nature of bridge crossing designs, and in the interest of minimizing revisions, schedule a pre-design meeting with the WSSC and technical staff with expertise in structural, civil and corrosion design. Representative(s) of the Bridge Authority and/or Right of Way Authority should attend the meeting if there are design issues which are contingent to the authorities' approval of the crossing.
- 2) The design meeting can be scheduled following the receipt of the bridge crossing conceptual approval from the WSSC, the Bridge Authority and the Right of Way Authority. Prepare for the meeting with the submittals indicated above, along with the proposed conceptual design to include items such as the proposed method of pipe support, pipe material and joint type, number and location of expansion joints, proposed coating/lining, etc.

**e. Allowable Pipeline Material.**

- 1) Ductile Iron Pipe (DIP). Provide in accordance with Specifications and give special consideration to the design of the wall thickness (pipe class) for the DIP, see Part One, Section 4 (Selection of Pipe Material) and any special requirements of the Bridge Authority and/or the Right of Way Authority. WSSC generally prefers that crossings using DIP, are short crossings with restrained mechanical joints, see Part One, Section 3 (Pipe and Fitting Joints) for limitations.
  - a) Allowable pipe joints. Provide in accordance with Specifications and Part One, Section 3 (Pipe and Fitting Joints), and the design considerations listed below.
    - (1) Restrained mechanical joints. Generally, WSSC prefers that pipeline bridge crossing designs, which use DIP, have restrained mechanical joints in combination with a roller support system and a pipe expansion joint. Restrained mechanical joint systems allow for the following:
      - (a) Resists thrust forces.
      - (b) Effectively separates the pipeline from the bridge structure allowing each to act independently.
      - (c) Transmits movement of the pipe due to thermal expansion and contraction to the respective expansion joint without pipe joint separation.



- (d) Provides extra security in the event of a support failure or damage by minimizing the possibility of pipe joint separation.
  - (e) When utilizing restrained joints, proper design techniques should include provisions for extending each joint so as to engage its restraints. Some restrained joints are subject to significant joint extension.
- (2) Proprietary push-on restrained joints. Generally, the use of proprietary bell push-on restrained joints for bridge crossings should be limited, due to the unique design and construction requirements when using these joints in above ground installations. These joints have an inherent amount of joint slack, which must be extended for the full length of the exposed pipeline following installation to prevent "snaking" and/or elongation of the pipeline following pressurization. Include provisions for extending each joint following pipe installation to remove slack from the joints.
- (3) Push-on joints. In most cases, WSSC will not permit DIP with push-on joints to be specified. Typically, most bridge configurations do not lend themselves to the use of unrestrained push-on joints. This type of joint is not restrained, therefore, the supports need to be designed and constructed (axially, laterally and vertically) to resist thrust forces, dead loads, impact and shock loads and thermal changes. If the design includes push-on joints, consider the following:
- (a) The pipe needs to be fixed securely to the supports or bridge structure at least behind each pipe joint.
  - (b) The pipe should not be installed on hangers using rods with little or no lateral supports.
  - (c) If properly fixed to the bridge to resist lateral and axial movements, this type of pipe joint can be used to relieve some of the expansion and contraction of the pipe and bridge structure due to temperature changes. Each joint should be brought fully home and then, depending on the ambient temperature conditions at the time of installation, backed out slightly to provide for the anticipated thermal expansion of the bridge structure. Provide calculations and indicate the withdrawal dimension on the drawings.
  - (d) If the bridge has an expansion joint(s), give special attention to account for the concentrated bridge expansion at the bridge expansion joint location(s) since the pipe is fixed to the bridge. The pipeline may require an expansion joint at this location or a design using restrained joint pipe may prove to be a better alternative depending on the amount of anticipated movement at the bridge expansion joint, see Design of the Pipeline for Expansion and Contraction in this section.
- (4) Unrestrained mechanical joints. Typically, the same as push-on joints, except give consideration to the relative expansion and contraction of the pipeline. If the pipeline is rigidly fixed at each joint to the bridge structure and the design intent is to allow the thermal expansion and contraction at the pipe joints, mechanical joint pipe may not be the best alternative because the pipe socket bell depth is shallower than push-on joints.
- (5) Flanged joints. Typically, flanged joints are only used for the installation of the expansion



joint and insulating joints. Provide flanged joints in accordance with Specifications and for design information; see Part One, Section 3 (Pipe and Fitting Joints).

- 2) **Steel pipe.** Generally, the WSSC prefers the use of steel pipe for long bridge crossings and crossings with pipe diameters greater than 24-inch, for steel pipe design information; see Part One, Section 2 (Pipe Materials and Fittings).
  - a) The steel pipe conceptual design is the same as for ductile iron with restrained joints, i.e. supported on a roller system with a pipe expansion joint(s). Steel pipe allows for the following:
    - (1) Resists thrust forces.
    - (2) Effectively separates the pipeline from the bridge structure.
    - (3) Transmits movement of the pipe due to thermal expansion and contraction to the respective expansion joint.
    - (4) Provides extra security in the event of a support failure or damage.
    - (5) Eliminates the possibility of a leak at a joint due to failed gasket, etc.
    - (6) When steel pipe is designed for a bridge crossing, the design must include insulating joints between the steel pipe and the buried ductile iron pipeline.

**f. Fittings on Bridge Structures.**

- 1) Pipe fittings, including bends, are not allowed within bridge spans beyond bridge abutments.

**g. Joint Deflections on Bridge Structures.**

- 1) Joint deflections should be avoided or minimized, if possible. When the design requires joint deflections, see requirements under Part One, Section 12 (Allowable Joint Deflections).
- 2) Joint deflections create a thrust force, which can be calculated similar to a bend. Small vertical joint deflections typically are counteracted by the weight of the pipe or the support system. Horizontal joint deflections, however, create a lateral force, which may require a special support design. In either case, avoid joint deflections, if possible. If the design requires joint deflections, provide calculations for the thrust forces at the joint deflections and design the support system accordingly.

**h. Pipeline Coating Requirements.**

- 1) Provide pipeline, appurtenances, and the pipe support system with an exterior coating comparable with the life expectancy of the bridge coating system and suitable for the corrosive effects of road salts, atmospheric and weather conditions.
- 2) Include in the Specifications, installation precautions and special provisions for the protection, application and repair of the exterior coatings during construction.



- 3) During design, take into consideration how the pipe will be installed; i.e., if a shop coated pipe will be launched across the supports, non-metallic rollers will minimize damage.

**i. Pipeline Identification.**

- 1) Provide identification markings as listed below, on the bottom exterior of the pipeline, when the Bridge Authority requires pipeline identification; also see MSHA utility policy.
  - a) Utility name (WSSC).
  - b) Pipeline working pressure (psi).
  - c) Contents (water, sewer, etc.).
  - d) Conform to industry standards for the contents for pipe coating color, when required. Typically, match the pipeline coating color to the bridge structure unless otherwise directed.
  - e) Size of the lettering, one third the pipe outside diameter, but not larger than 4-inch in height and installed on the pipeline by decals or stenciling with a high quality print.
  - f) Provide the above information on the pipeline within 50 feet from the bridge abutment and at intervals of 200 feet in between. Adjust the spacing to have one identification marking in every bay bounded by beams and diaphragms through which the pipeline passes.

**j. Design of Pipelines in Casing Pipes.**

- 1) If required by the Bridge Authority or by the Right of Way Authority, design the pipeline in a steel casing pipe.
- 2) If a casing pipe is required, provide provisions to drain condensation from the casing pipe.

**k. Isolation Valves.**

- 1) **For water** pipelines that will be attached to bridge structures must have valves placed on each side of the bridge for isolating the pipeline on the bridge. For sewerage force mains valves are not required.
- 2) The valves must be located and designed for thrust restraint in the closed position, see Part Three, Section 27 (Thrust Restraint Design for Buried Piping) under "When and How to Restrain Valves". Valves must be located far enough away from the bridge abutment/backwall, so that any maintenance on the bridge structure/foundation will not disturb the valves or compromise the valve restraint system.

**l. Location of the Pipeline on the Bridge Structure.**

- 1) There are three general **alternatives** on where a pipeline could be located on bridges. They include under the bridge between two adjacent girders, on the exterior side of the bridge, and within a designated utility corridor. The location chosen for design will depend on factors such as the configuration and material construction of the bridge, accessibility for maintenance of the



pipeline and the bridge, **aesthetic considerations**, etc. In any case, the following guidelines apply and approval of the location is required.

a) Horizontal location.

- (1) Pipelines on MSHA bridge structures are typically placed under the bridge between the bridge girders, preferably between the fascia and the first interior girder. This alignment places the pipeline on the shoulder of the approaches to the bridge as it enters and exits the bridge structure and also prevents the pipe from being visible from below to approaching traffic/etc.
- (2) Pipelines on other jurisdictional bridge structures are to be located according to the requirements of the particular Bridge Authority. Preferably, locate the pipeline according to the requirements of MSHA, as noted above. In cases when the pipeline is not located under the bridge between two adjacent girders, contain the pipeline within the confines of the bridge superstructure.

b) Vertical location.

- (1) Vertical clearance between the bridge and the roadway, railroad, etc. must not be reduced. Entire installation (pipeline, pipe supports, supporting brackets, etc.), must be above the bottom of the highest adjacent bridge girder.
- (2) Provide a minimum 6-inch vertical clearance between the top of the pipe or pipe bells/flanges and the underside of the bridge deck or structural members, unless otherwise approved or required. Evaluate the possible vertical travel of the pipe due to deflection of the bridge structure and provide adequate clearance accordingly.

**m. Buried Pipelines Entering the Bridge Structure.**

- 1) Design the pipeline so that thrust forces of the buried pipeline are not transferred to the bridge structure.
- 2) The piping is to pass through the bridge backwall/abutment in a sleeve.
  - a) Design the sleeve using steel pipe with a seep ring sized large enough to allow for installation and removal of the pipeline.
  - b) If a fabricated pipe such as a mechanical joint by flanged pipe (MJ by FLG) must pass through the sleeve, provide the diameter of the sleeve large enough to allow the smallest pipe joint to pass through.
  - c) Seal the void between the pipeline and the sleeve to prevent seepage of ground water through the sleeve.
  - d) If the area in front of the bridge backwall/abutment has a concrete approach slab, consider installing the pipeline in a sleeve or casing pipe. Extend the sleeve or casing pipe through the backwall/abutment and two (2) feet beyond the limits of the approach slab. Support the pipeline in the sleeve with suitable pipe supports or insulated casing spacers. The void



between the pipeline and the sleeve must be sealed to prevent seepage of ground water through the sleeve.

- 3) Provide the following minimum cover over the buried pipeline:
  - a) Typically, the pipeline minimum cover is 4'-0" of cover over the top of the pipe, see Part One, Section 11 (Vertical Alignment – (Profiles)).
  - b) At the bridge backwall/abutment, the minimum cover can be reduced to 3'-0". Provide the first and subsequent buried pipe joints with vertical deflections down, so that 4'-0" cover over the pipeline is achieved as soon as possible.
  - c) In some cases, the minimum cover requirement can be modified to allow for cover less than the 3'-0" stated above. **In such cases** submit the design along with calculations (**See Part One, Section 4. Selection of Pipe Material**), **to WSSC approval**.
- 4) Pipeline provisions for differential settlement of bridge/backfill.
  - a) Due to the potential for settlement of the backfill behind the bridge abutment wall, provide provisions to prevent damage to a pipeline where it passes rigidly through the abutment wall.
  - b) One method used for this purpose includes providing two pipe joints several feet apart just outside of the wall in the buried portion of the pipeline to allow the pipe in the fill to settle independently of the pipe fixed in the abutment wall.

**n. Pipe Thrust on the Bridge Structure.**

- 1) The alignment of the pipeline should be in such a way that the bridge structure is not subject to residual thrust forces.
- 2) For pipeline material, see Allowable Pipeline Material, in this section. Restrain all joints to prevent joint separation. Also see the requirements for Design of the Pipeline for Expansion and Contraction in this section.

**o. Pipe Load on the Bridge Structure.**

- 1) When the pipeline is designed in a straight alignment, the primary pipe loading on the bridge structure is the pipe dead load which includes the weight of the pipe full of water, the weight of the pipe appurtenances (expansion joints, couplings, etc.), and the weight of the pipe support system.
- 2) Other pipe loads that should be evaluated are as specified by AASHTO **and ASCE 7**. (wind, **Ice**, earthquake, shock, impact, etc.).

**p. Attaching the Pipeline to the Bridge Structure.**

- 1) Special bridge design requirements to accommodate the pipeline.
  - a) Coordinate the design of the pipeline support system with the Bridge Authority's engineer.



- b) The design should not include welding directly to the bridge structural members, unless otherwise approved by the Bridge Authority.
  - c) **Coordinate** the pipe location **with** components of the bridge structure, so that the design of the pipeline will not interfere with the bridge **joints, members, etc.**
- 2) Supporting the pipeline on the bridge structure.
- a) Design the support system based on the following standards:
    - (1) DIPRA (Ductile Iron Pipe Research Association), Design of Ductile Iron Pipe on Supports.
    - (2) MSS (Manufacturer Standardization Society), Standard Practice SP-69, Pipe Hangers and Supports - Selection and Application.
    - (3) ASTM F 708, Design and Installation of Rigid Pipe Hangers.
    - (4) AISC (American Institute of Steel Construction) Manual of Steel Construction.**
  - b) Attaching the supports to the bridge.
    - (1) Support the pipeline by the bridge diaphragms. If this is not possible, a cross member will be needed to attach the pipe hanger/support to the bridge girders.
    - (2) Additional supports may be required and must be attached to the bridge girders or beams by nuts and bolts. No welding directly to the bridge structural members will be permitted in the design, unless otherwise approved by the Bridge Authority.
    - (3) Bridge members and receiving pipe supports need to be evaluated for local stress due to additional loads, including, but not limited to local and distortional buckling, etc.**
  - c) Coordinate the support location, type of supports, etc. with the Bridge Authority.
  - d) Design the pipeline supports such that any movements due to thermal expansion and contraction of the pipeline on the supports will not damage the pipe coatings or linings. Design the supports for free axial movement of the pipeline, unless the pipeline is designed to be restrained by the supports, (i.e. fixed to the bridge at each pipe joint).
  - e) Select pipe support materials which do not promote galvanic action and electrically insulate the pipeline from the pipe supports.
  - f) Design the supports to prevent lateral and vertical movement. Any anticipated shock or impact loading needs to be considered when selecting and specifying the pipe hangers, rollers, supports, etc.
  - g) Support Spacing. For DIP **with** supports behind each bell joint, and at a nominal spacing of ten (10) feet on center i.e., a minimum of two (2) supports per pipe length. For steel pipe, provide design calculations for support spacing.





**q. Design of the Pipeline to Prevent Freezing.**

- 1) MSHA requires all pipelines 12-inch and smaller diameter on MSHA bridges to be designed with insulation to prevent freezing. Verify with MSHA if the insulation will be required prior to proceeding to incorporate it into the design.
- 2) For all pipeline bridge crossings, evaluate freezing in the design. Provide calculations with the assumptions and method used for the analysis. If required, provide insulation to protect the pipeline from freezing. Provide a design to facilitate any future maintenance. Support and protect the insulation from damage with a suitable shield.

**r. Design of the Pipeline for Expansion and Contraction.**

- 1) Conditions.
  - a) Fluid flow inside a pipeline as well as ambient temperature changes throughout the year will affect expansion and contraction of the pipeline with respect to the bridge.
    - (1) Consider thermal expansion and contraction of the pipeline and the bridge and provide the necessary provisions in the design.
    - (2) The bridge expansion could differ from the pipeline for the following reasons:
      - (a) Differences between the pipeline and bridge temperature. The pipe temperature being affected by the temperature of its contents (water or sewerage).
      - (b) Differences in the coefficients of thermal expansion between the pipeline material and the bridge material.

**TABLE "24"**  
Coefficients of Thermal Expansion

Material	Coefficient
Ductile Iron Pipe	0.0000062 inch/inch ° F
Steel Pipe	0.0000063 inch/inch ° F
Structural Steel	0.0000065 inch/inch ° F
Reinforced Concrete	0.0000070 inch/inch ° F

- b) The location of the bridge expansion joint may concentrate movement relative to the pipeline.
- c) Expansion and contraction in conjunction with thrust forces could introduce excessive stresses on the pipeline, pipe joints and/or the pipeline supports. Design the pipeline so that axial thrust forces are not transmitted across the pipe expansion joint.
- d) If DIP with push-on joints (not restrained) is specified. Restraining the pipe behind the bell to the bridge may be adequate to account for thermal expansion with proper joint assembly provided that special provisions are provided for pipe expansion/contraction for the concentrated movement at the location of the bridge expansion joint, see Push-on Joints in this section.



- 2) Location and number.
  - a) The location and number of expansion joints is determined by the length of the pipeline, the maximum anticipated temperature differential and the amount of movement which can be accommodated by the particular expansion joint being specified.
  - b) Expansion joints are utilized to accommodate thermal movements of the pipe and bridge in longer crossings and bridges with multiple spans. Expansion joints may be required at the location of the bridge expansion joints, especially if the pipeline is fixed to the bridge structure.
  - c) Where practical and permissible by the particular design, locate the expansion joint where it can be easily accessed for inspection and maintenance.
- 3) Restraint of expansion joints.
  - a) Type of joint ends. For ductile iron pipelines, design the expansion joint with flanged or restrained mechanical joint ends and for steel pipelines, design the expansion joint with flanged ends or beveled ends for welding.
  - b) Force required to actuate expansion joint. Due to the design of pipe expansion joints, they can often require a significant pulling force to actuate the joint. This force varies based on the design of the particular joint. Obtain this information from the manufacturer of the joint being specified. Therefore, the pipeline must be anchored sufficiently to resist this force and engage the expansion joint. Verify the force required to actuate the joint with the expansion joint manufacturer, and restrain or anchor the pipe accordingly. (As a conservative analytical practice, consider the pipeline empty when calculating the buried length of restrained pipe for two reasons; so the weight of the liquid will be considered as an additional safety factor and the possibility of the pipeline being empty during a period of time).
- 4) Types of pipe expansion joints.
  - a) Steel pipe and DIP. There are at least two types of expansion joints which are suitable for DIP and steel pipe. These include the steel single end type as well as a ductile iron expansion joint such as the Ex-Tend™ as manufactured by EBBA Iron, Inc.
    - (1) Single end type. This type of joint is most suitable for steel pipe crossings, however, it is also commonly used for DIP. It is generally fabricated from steel having a packing chamber to form a seal between a slip pipe and the body of the joint. Common manufacturers are Dresser Industries and Smith-Blair, Inc.
    - (2) Ductile iron expansion joint. The ductile iron expansion joint such as the joint manufactured by EBBA Iron, Inc. known as the Ex-Tend™, is available with mechanical joint ends and is well suited when designing a crossing using restrained mechanical joint DIP. It is also available with flanged ends allowing it to be used for steel pipe.



**s. Design of Dewatering and Air Release Appurtenances on Bridge Structures.**

- 1) Do not design air release and blowoff connections within the bridge structure.
- 2) Design the pipeline between the required isolation valves to allow the pipeline to be drained by gravity. Provide a blow-off connection in the buried portion of the pipeline according to Part One, Section 23 (Blowoff Connections).

**t. Pipelines to be Abandoned on the Bridge Structure.**

- 1) When the pipeline is no longer required on the bridge structure, WSSC will notify the Bridge Authority. If the Bridge Authority decides that the pipeline must be removed, the following will be required.
  - a) Abandonment plan, showing the limits of what is to be removed from the bridge structure.
  - b) Abandonment of the buried portion of the pipeline in accordance with Part Three, Section 5 (Pipeline Abandonment).

**u. References.**

- 1) MSHA (Maryland Department of Transportation-State Highway Administration), MSHA Utility Policy "July 1989" revised May 1994.
- 2) ASCE, Pipeline Division, "Pipeline Crossing Proceedings, Special Conference, Denver, CO., March 25-27, 1991, Bridge Crossings with Ductile Iron Pipe by Michael S. Tucker."



## 11. Loading Analysis of Existing Pipelines.

### a. General.

- 1) The intent of the following guidelines is to establish criteria and procedures to evaluate the impact of changing the grade or loading conditions over the existing water and sewer pipelines. Use these guidelines in conjunction with Part Three, Section 12 (Related Design and Analysis).
- 2) Submit the documentation along with your analysis to support the parameters and assumptions used such as, as-built plans, Specifications, special provisions to the Specifications, Standard Details, ASTM standards, evidence of existing and proposed soil cover, test pit data, **type of construction equipment to be used around and over WSSC pipelines**, etc.
- 3) During the analysis of the existing pipeline, request the WSSC research the break/leak history of the existing pipeline. Compare the cost of replacing the existing pipeline within the impact area verses repair/restoration after the impact of changing the grade or loading conditions.

### b. Abbreviations.

AASHTO	American Association of State Highway and Transportation Officials
ANSI	American National Standards Institute
ASA	American Standards Association
ASTM	American Society for Testing and Materials
AWWA	American Water Works Association
SAMM	Spangle and Marston Method
USAS	USA Standards

### c. Ductile Iron Pipe (DIP) Water Pipelines.

- 1) DIP is considered a flexible pipe, therefore, the method of thickness design is based on flexible pipe principles. The required thickness of DIP is determined by considering internal pressure and trench load separately, both of which are applicable to water mains. Evaluate the proposed change in loading conditions or soil cover by calculating the required pipe thickness class using ANSI A21.50/AWWA C150. Compare the required thickness for the proposed conditions, with the actual pipe class provided.
- 2) In order to evaluate existing DIP for a change in loading conditions, the following information is needed to calculate the required pipe thickness class using ANSI A21.50/AWWA C150:
  - a) Pipe soil cover. Determine pipe soil cover from the proposed design and the existing pipe invert from the as-built plans. If there is evidence that the pipe may be at an elevation significantly different than that shown on the as-builts or if the proposed depth of cover is within one (1) foot of the maximum or minimum allowable, then perform test pit(s) to determine the actual elevation of the pipe.
  - b) Pipe working and surge pressures, see Part One, Section 5 (Total Internal and Transient Pressures).
  - c) Standard pipe laying condition. Determine the standard pipe laying condition according to



ANSI A21.50/AWWA C150 under which the original pipe was installed. Information on bedding and backfill for the pipe may be found in the Specifications and Standard Details in effect at the time of the pipe installation to determine the laying condition used. If the actual laying condition for the pipe in question cannot be determined by researching the contract documents, then for analysis assume Type 1, flat bottom trench with loose backfill.

- d) Class of pipe. Type and class of DIP is typically indicated on the drawings. If the pipe class is not indicated on the as-built drawings, it may be found by researching the available contract documents and correspondence contained on microfilm or original construction files, which are available through the WSSC. If the actual class cannot be determined from the available contract documents, assume the weakest class for analysis.

#### d. Cast Iron Pipe (CIP) Water Pipelines.

- 1) CIP is considered a rigid pipe. The required thickness of cast iron pipe is determined by considering internal pressure and trench load in combination, both of which apply to water mains. Improvements in manufacturing techniques and the development of higher strengths of iron have resulted in having two types of CIP with different iron strengths, which include pit cast and centrifugally cast pipe in the WSSC system. The method of evaluating the required thickness class of both types and iron strengths is the same using ASA/USAS A21.1, (AWWA H1).
- 2) CIP analysis considerations. Some of the existing CIP water mains in the WSSC system may be older than 75 years. When evaluating existing CIP for additional loading, consider the age and probable condition of the pipe. It is preferable that additional loading be avoided on old existing CIP because the condition of the pipe is usually not known. The WSSC has repair history records of the pipes in the system which has had leaks or breaks. This information should be used to determine the serviceability of the existing pipe. Prior to changing the loading conditions over old CIP, make a judgment and recommendation to WSSC as to the serviceability and apparent condition of the pipe.
- 3) To evaluate existing CIP for a change in soil cover or loading conditions according to ASA/USAS A21.1 (AWWA H1), the following information is needed:
  - a) Soil pipe cover. Determine pipe soil cover from the proposed design and the existing pipe invert from the as-built plans. If there is evidence that the pipe may be at an elevation significantly different than that shown on the as-builts or if the proposed depth of cover is within one (1) foot of the maximum or minimum allowable, then perform test pit(s) to determine the actual elevation of the pipe.
  - b) Working and surge pressures, see Part One, Section 5 (Total Internal and Transient Pressures).
  - c) Standard pipe laying condition. Determine the standard pipe laying condition according to ASA/USAS A21.1, also called "Field Condition" in the 1939 and 1957 version of A21.1. The majority of cast iron pipes in the WSSC system were laid using a Type "A" condition, which is a flat bottom trench with untamped backfill. If it can be conclusively determined that other than a Type "A" condition was used, from either researching the contract documents and applicable Standard Details and Specifications, or test pit (i.e. presence and extent of granular bedding), then use the actual laying condition in the analysis.



- d) Type of pipe and thickness class. The following guidelines are for information only and intended to aid in determining the class/type of pipe used. However, they are general guidelines only and the necessary research is to be performed to determine the actual type/class of existing pipe.
- (1) Improvements in manufacturing and cast iron strengths resulted in having two types of CIP with differing iron strengths in WSSC system. The two types are pit cast, used primarily prior to 1954 and centrifugally cast used after 1954. For contracts newer than 1968, the class of pipe is typically noted on the as-built plans. For contracts between 1954 and 1968, typically centrifugally cast, class 150 CIP was used according to the 1954 Specifications, unless indicated otherwise on the plans or in the specifications. For contracts prior to 1954, the class of pipe typically is not included on the as-builts and specifications may not be available.
  - (2) In general, if the pipe class is not indicated on the as-built drawings, it may be found by researching the available contract documents and correspondence contained on microfilm or original construction files, which are available through the WSSC. If the type of pipe class cannot be conclusively determined through researching the contract documents, then for analysis use the weakest class/type of pipe available during the time period when the pipe was manufactured.
- e) Earth and live loads.
- (1) Compute the earth load using the Marston method of design for determining loads on rigid conduits, see ANSI A21.1 -1972 or the Concrete Pipe Handbook (1988) for the design method. In addition, the "SAMM" computer program (September 1990), distributed by American Concrete Pipe Association, can also be used for this purpose. In cases where a proposed surcharge fill is being added over an existing pipe which was originally installed under a ditch (trench) condition, the negative projection embankment condition shall be considered to evaluate the earth load on the rigid pipe due to the proposed fill. Determine the earth load using the following parameters:
    - (a) Unit weight of soil ( $\gamma$ ).  
Assume  $\gamma = 120 \text{ lb/ft}^3$ , unless actual soil samples are taken to prove otherwise
    - (b) Trench width at top of pipe.
      - [1] For pipes smaller than 16-inch in diameter, use 30-inch or the trench width found in the applicable Standard Detail or Specification, whichever is greater.
      - [2] For 14-inch diameter pipe, use the trench width for a 15-inch pipe indicated in the applicable Standard Detail. If evidence of a wider trench width exists, then use the actual condition.
      - [3] For pipes 16-inch and larger in diameter, earth loads shall be calculated assuming original installation was in a transition width trench.
    - (c) Assume soil type as ordinary clay, unless actual soil samples are taken to prove otherwise.



- (2) Evaluate truck and superimposed live loads on rigid pipe, using the method presented in the Concrete Pipe Design Manual, 1992 and/or the Concrete Pipe Handbook, 1988 both by the American Concrete Pipe Association which is based on Holl's integration of Boussineq's equations. In addition, the "SAMM" computer program (September 1990), distributed by American Concrete Pipe Association, can also be used for this purpose. The maximum highway wheel load used for analysis is the maximum of those specified by AASHTO in "Standard Specification for Highway Bridges" for H20 and HS20 plus impact for a single dual wheel, two (2) passing HS20 trucks and alternate loads in the passing mode. When the depth, of cover over the pipe exceeds nine (9) feet, the live load can be neglected.

**e. Polyvinyl Chloride (PVC) Pipe AWWA C-900 DR 14 Water Pipelines.**

- 1) PVC pipe is a flexible pipe, which interacts with the surrounding soil as to create a pipe-soil system which act together to support the over burden loading. The deflection of the PVC pipe at the springline transfers a portion of the load to the surrounding soil. PVC pipe interacts with the surrounding soil to support the load, the bedding/backfill properties are very important.
- 2) The maximum allowable soil cover over existing PVC water pipelines is twenty-five (25) feet, with no borrow aggregate and forty (40) with no borrow aggregate in accordance with Standard Detail W/6.1. For existing PVC gravity sewers use Standard Detail M/8.1a and the Specifications. The minimum allowable cover over PVC is three (3) feet.
- 3) In order to evaluate existing PVC for a change in loading conditions, the following information is the following:
  - a) Pipe soil cover. Determine pipe soil cover from the proposed design and the existing pipe invert from the as-built plans. If there is evidence that the pipe may be at an elevation significantly different than that shown on the as-builts or if the proposed depth of cover is within one (1) foot of the maximum or minimum allowable, then perform test pit(s) to determine the actual elevation of the pipe.
  - b) Pipe working and surge pressures, see Part One, Section 5 (Total Internal and Transient Pressures).
  - c) Standard pipe laying condition. Determine the standard pipe laying condition according to AWWA C605 under which the original pipe was installed. Information on bedding and backfill for the pipe may be found in the Specifications and Standard Details in effect at the time of the pipe installation to determine the laying condition used. If the actual laying condition for the pipe in question cannot be determined by researching the contract documents, then for analysis assume Type 1, flat bottom trench with loose backfill.

**f. Prestressed Concrete Cylinder Pipe (PCCP) Water Pipelines.**

- 1) Prestressed Concrete Cylinder Pipe (PCCP) is a rigid concrete pipe reinforced with high tension prestressing wire. The design of the pipe is site specific, i.e., the pipe is custom designed for the specific site conditions where it will be used. Therefore, the pipe specifications and pipe classes for each contract are typically unique and only apply to that contract.

The supporting strength of PCCP, like that of cast iron pipe, is determined by considering



simultaneous combined loading of internal pressure and external load. The operating point (working pressure vs. earth load) of the pipe must fall within the bounds of the parabolic design curve for the pipe. The transient point (working pressure plus surge pressure vs. earth load plus live load) must fall within the bounds of a separate transient curve or first-crack curve.

- 2) **Analysis.** To determine the adequacy of PCCP under various loading conditions, first plot the design curve using information from the PCCP manufacturer's specification. The general design procedure is presented in Appendix A of AWWA C301, which defines the design curve, by the following equation:

$$w = W_0 \times (P_0)^{-1/3} \times (P_0 - p)^{1/3}$$

Where:

$P_0$  = the internal pressure required to overcome all compression in the core concrete

$W_0$  = nine tenths (0.9) of the 3-edge bearing load producing incipient cracking in the core with no internal pressure

$p$  = maximum design pressure in combination with 3-edge bearing load,  $w$ , equivalent to the maximum earth load divided by the bedding factor

$w$  = maximum 3-edge bearing load, equivalent to load, in combination with design pressure  $p$

- a)  $W_0$  is computed based upon the equation below. The information that is needed to solve this equation comes from the pipe manufacturer's specification/data sheets for each project and from the manufacturer's catalogue. The specification/data sheets can generally be found by researching the available contract documents and correspondence contained on microfilm or original construction files, which are available from WSSC.

$$W_0 = 0.9 \times W_{0.001}$$

$$W_{0.001} = \left( \left( (17.94 \times T_w^2) \div D_m \right) \times (f_{cr} + 600) \right) - (0.91 \times W_t)$$

Where:

$T_w$  = wall thickness of pipe, inches

$W_t$  = weight of pipe, pounds per linear foot

$D_m$  = mean pipe diameter

= ID +  $T_w$ , inches

$f_{cr}$  = resultant compression in concrete, psi

- b) For embedded-cylinder (SP-12) pipe,  $P_0$  is plotted as the x-intercept and  $W_0$  is plotted as the y-intercept).
- c) For lined-cylinder (SP-5) pipe,  $0.8 \times P_0$  is plotted as the x-intercept.
- d) Once the design curve is plotted, plot the operating point of the section of pipe under consideration. The abscissa of the operating point consists of the internal operating pressure of the pipe at the elevation of the pipe under analysis and the ordinate consists of the amount of proposed earth load over the pipe. The amount of earth load should reflect the increase or decrease in fill over the pipe, depending on the proposed grading. The proposed earth load should reflect the same assumptions made for large diameter sewer pipe. If the operating point falls within or on the  $W_0 P_0$  parabolic curve, then the pipe with revised grading is adequate for operating conditions.
- e) Next, the transient and first-crack curves must be plotted. For the pipe to be adequate for





transient conditions, the transient point must fall within these curves. The transient curve is also a parabolic curve, but with y-intercept equal to  $(1.2 \times W_0)$  and x-intercept equal to  $(1.1 \times P_0)$ . The first-crack curve, likewise, is a parabolic curve with y-intercept at  $W_{0.001}$  and the x-intercept at  $[P_0 \times (f_{cr} + 300) \div f_{cr}]$ , where  $f_{cr}$  is the resultant concrete core stress which is given in the PCCP manufacturer's specification/data sheet.

- f) The plotting and graphing numbers on the abscissa are generally expressed as a fraction of  $P_0$  and the numbers on the ordinate are usually expressed as fractions of  $W_0$  (earth and live loads are divided by the bedding factor and then expressed as a fraction of  $W_0$ ).

3) Information required for analysis.

- a) Determine pipe soil cover from the proposed design and the existing pipe invert from the as-built plans. If there is evidence that the pipe may be at an elevation significantly different than that shown on the as-builts or if the proposed depth of cover is within one (1) foot of the maximum or minimum allowable, then perform test pit(s) to determine the actual elevation of the pipe.
- b) Working and surge pressures, see Part One, Section 5 (Total Internal and Transient Pressures).
- c) Pipe specifications and class of pipe.
- d) Earth and live loads.

- (1) Compute the earth load using the Marston method of design for determining loads on rigid conduits, see ANSI A21.1-1972 or the Concrete Pipe Handbook (1988) for the design method. In addition, the "SAMM" computer program (September 1990), distributed by American Concrete Pipe Association, can also be used for this purpose. In cases where a proposed surcharge fill is being added over an existing pipe which was originally installed under a ditch (trench) condition, consider the negative projection embankment condition, to evaluate the earth load on the rigid pipe due to the proposed fill. Determine the earth load using the following parameters:

- (a) Unit weight of soil ( $\gamma$ ).

Assume  $\gamma = 120 \text{ lb/ft}^3$ , unless actual soil samples are taken to prove otherwise

- (b) Trench width at top of pipe. When calculating earth loads on PCCP, assume a transition width trench.

- (c) Assume soil type as ordinary clay, unless actual soil samples are taken to prove otherwise.

- (2) Evaluate truck and superimposed live loads on rigid pipe, using the method presented in the Concrete Pipe Design Manual, 1992 and/or the Concrete Pipe Handbook, 1988 both by the American Concrete Pipe Association which is based on Holl's integration of Boussineq's equations. In addition, the "SAMM" computer program (September 1990), distributed by American Concrete Pipe Association, can also be used for this purpose. The maximum highway wheel load used for analysis is the maximum of those specified by AASHTO in "Standard Specification for Highway Bridges" for H20 and HS20 plus impact for a single dual wheel, two (2) passing HS20 trucks and alternate loads in the passing mode. When the depth of cover over the pipe exceeds nine (9) feet, the live load can be neglected.



e) Standard pipe laying condition.

- (1) To determine the actual pipe laying condition and Bedding Factor ( $B_f$ ), see Figure "C" in this section. Information on bedding and backfill for the pipe may be found in the Specifications and Standard Details in effect at the time of the pipe installation to determine the laying condition used.
- (2) If the actual laying condition cannot be determined from researching the available contract documents and correspondence contained on microfilm or original construction files, which are available through WSSC or applicable Specifications and Standard Details or by test pit (i.e. presence and extent of any granular bedding), then use class D, flat subgrade with loose backfill,  $B_f = 1.1$  for analysis.

**g. Asbestos Cement Pipe (ACP) Water Pipelines.**

- 1) ACP was used for water mains on a very limited basis when indicated in the special provisions according to the 1968 WSSC Specifications. Small diameter (4-inch through 16-inch) water pipe was produced according to ANSI/AWWA C400-77. The supporting strength of existing ACP water pipelines shall be determined using ANSI/AWWA C401-77, AWWA Standard Practice for the Selection of Asbestos-Cement Distribution Pipe 4-inch through 16-inch for Water and Other Liquids.

**h. Polyvinyl Chloride (PVC) SDR 35 Pipe Sewer Pipelines.**

- 1) PVC pipe is a flexible pipe, which interacts with the surrounding soil as to create a pipe-soil system which act together to support the over burden loading. The deflection of the PVC pipe at the springline transfers a portion of the load to the surrounding soil. PVC pipe interacts with the surrounding soil to support the load, the bedding/backfill properties are very important.
- 2) The maximum allowable soil cover over existing PVC gravity sewers is twenty-two (22) feet in accordance with Standard Detail M/8.2. For existing PVC gravity sewers use Standard Detail M/8.2 and the Specifications. The minimum allowable cover over gravity sewers is three (3) feet.

**i. Polyvinyl Chloride (PVC) Pipe AWWA C-900/905 Sewer Pipelines.**

- 4) PVC pipe is a flexible pipe, which interacts with the surrounding soil as to create a pipe-soil system which act together to support the over burden loading. The deflection of the PVC pipe at the springline transfers a portion of the load to the surrounding soil. PVC pipe interacts with the surrounding soil to support the load, the bedding/backfill properties are very important.
- 5) The maximum allowable soil cover over existing PVC gravity sewer shall be in accordance with Standard Detail W/6.1. For existing PVC gravity sewers use Standard Detail M/8.1a and the



Specifications. The minimum allowable cover over PVC is three (3) feet.

- 6) In order to evaluate existing PVC for a change in loading conditions, the following information is following:
- a) Pipe soil cover. Determine pipe soil cover from the proposed design and the existing pipe invert from the as-built plans. If there is evidence that the pipe may be at an elevation significantly different than that shown on the as-builts or if the proposed depth of cover is within one (1) foot of the maximum or minimum allowable, then perform test pit(s) to determine the actual elevation of the pipe.
  - b) Standard pipe laying condition. Determine the standard pipe laying condition according to AWWA C605 under which the original pipe was installed. Information on bedding and backfill for the pipe may be found in the Specifications and Standard Details in effect at the time of the pipe installation to determine the laying condition used. If the actual laying condition for the pipe in question cannot be determined by researching the contract documents, then for analysis assume Type 1, flat bottom trench with loose backfill.

**j. Ductile Iron Pipe (DIP) Sewer Pipelines.**

- 1) DIP is considered a flexible pipe, therefore, the method of thickness design is based on flexible pipe principles. The required thickness is determined by considering internal pressure and trench load separately. For DIP gravity sewers, there is no internal pressure, only trench load. Evaluate the proposed change in soil cover by calculating the required thickness class using ANSI A21.50/AWWA C150. Compare the required thickness for the proposed conditions with the actual pipe class provided. The minimum allowable cover for gravity sewers is three (3) feet. The maximum deflection of cement lined DIP gravity sewer **cannot** exceed three (3%) percent.
- 2) Information required to evaluate existing DIP sewers is the same as DIP water mains, except working and surge pressure are not required. See requirements in Ductile Iron Pipe (DIP) Water Pipelines, in this section.

**k. Vitrified Clay Pipe Extra Strength (VCPX), Concrete Sewer Pipe Extra Strength (CSPX), and Asbestos Cement Pipe (ACP) Sewer Pipelines.**

- 1) VCPX, CSPX and ACP are non-reinforced rigid pipes. The supporting strengths are specified in the ASTM standards in terms of the minimum ultimate strength (crushing strength) by the standard Three Edge Bearing (TEB) laboratory test. To compute the required three edge bearing strength of these non-reinforced pipes under a certain loading condition, use the following equation:

$$\text{Required TEB Strength} = [(W_l + W_e) \times FS] \div B_f$$

Where:

TEB = Three Edge Bearing crushing load for the pipe in lbs/ft

$W_e$  = earth load on the pipe in lbs/ft

$W_l$  = live load on the pipe in lbs/ft

$B_f$  = bedding factor, the ratio between the actual supporting strength of the buried field installed pipe to the strength of the pipe determined in the TEB laboratory test

FS = factor of safety, WSSC standard is 1.5



2) The information required to evaluate VCPX, CSPX and ACP sewer pipe is as follows:

a) Pipe soil cover. Determine pipe soil cover from the proposed design and the existing pipe invert from the as-built plans. If there is evidence that the pipe may be at an elevation significantly different than that shown on the as-builts or if the proposed depth of cover is within one (1) foot of the maximum or minimum allowable, then perform test pit(s) to determine the actual elevation of the pipe.

b) Three edge bearing strengths.

(1) ANSI/ASTM standards. The minimum three edge bearing strengths shall be obtained from the ANSI/ASTM standards under which the particular pipe was manufactured. ANSI/ASTM standards are periodically revised and updated, therefore the pipe strengths must be obtained from the applicable specification at the time the pipe was manufactured. If uncertain if the specification is applicable or if it is not available, then obtain the standards for several years before and after the pipe was installed. If the minimum TEB strength of the pipe remained unchanged, then it may be used for analysis.

(2) The applicable pipe specifications (for information only) are as follows, unless otherwise indicated or modified by the applicable Specifications or special provisions for the contract in question:

VCPX - ASTM C200, Extra Strength Clay Pipe, replaced in 1973 by ASTM C700, Vitrified Clay Pipe, Extra Strength, Standard Strength, and Perforated.

CSPX - ASTM C14, Concrete Sewer, Storm Drain, and Culvert Pipe.

ACP - ASTM C428, Asbestos-Cement Non-Pressure Pipe and ASTM C644, Asbestos-Cement Non-Pressure Small Diameter Sewer Pipe

(3) Standard pipe laying condition.

(a) To determine the actual pipe laying condition and Bedding Factor ( $B_f$ ), see Figure "C" in this section. Information on bedding and backfill for the pipe may be found in the Specifications and Standard Details in effect at the time of the pipe installation to determine the laying condition used.

(b) If the actual laying condition cannot be determined from researching the available contract documents and correspondence contained on microfilm or original construction files, which are available through WSSC or applicable Specifications and Standard Details or by test pit (i.e. presence and extent of any granular bedding), then use class D, flat subgrade with loose backfill,  $B_f = 1.1$  for analysis.

(4) Type of pipe.

(a) The type of pipe used is typically indicated on the as-built drawings in either the General Notes or on the as-built plans under "As-Built Data". If not indicated on the as-builts, it may be found by researching the available contract documents and correspondence



- contained on microfilm or original construction files, which are available through the WSSC.
- (b) If the type of pipe cannot be determined by researching the contract documents, then it may be possible to determine the type of pipe by going into a manhole or doing a test pit on the run of pipe in question; by visual inspection and verification of type/class by measuring the pipe wall thickness, outside diameter and/or inside diameter and comparing findings to pipe specifications.
  - (c) Existing sewers 24-inch and larger, are typically Reinforced Concrete Pipe (RCP), although some large diameter ACP and VCPX sewers exist in the system.
  - (d) If an option of several different pipe types is given on contract drawings and there is no indication on the as-builts which was used i.e., in the "As-Built Data", and all other means of determining the type of pipe have proven unsuccessful, then base the analysis upon the weakest pipe.
- (5) Earth and truck loads.
- (a) Compute the earth loads using the Marston method of design for determining loads on rigid conduits, see ANSI A21.1-1972 or the Concrete Pipe Handbook (1988) for the design method. In addition, the "SAMM" computer program (September 1990), distributed by American Concrete Pipe Association, can also be used for this purpose. In cases where a proposed surcharge fill is being added over an existing pipe which was originally installed under a ditch (trench) condition, consider the negative projection embankment condition, to evaluate the earth load on the rigid pipe due to the proposed fill. Determine the earth load on the following parameters:
    - [1] Unit weight of soil ( $\gamma$ ).  
Assume  $\gamma = 120 \text{ lb/ft}^3$ , unless actual soil samples are taken to prove otherwise
    - [2] Trench width at top of pipe.
      - [a] For pipes smaller than 16-inch in diameter, use 30-inch or the trench width found in the applicable Standard Detail or Specification used for construction, whichever is greater.
      - [b] For 14-inch diameter pipe, use the trench width for a 15-inch pipe indicated in the applicable Standard Detail used for the construction. If evidence of a wider trench width exists, then use wider width.
      - [c] For pipes 16-inch and larger, calculate earth loads assuming original installation was in a transition width trench.
    - [3] Assume soil type, ordinary clay, unless actual soil samples are taken to prove otherwise.
  - (b) Evaluate truck and superimposed live loads on rigid pipe, using the method presented in the Concrete Pipe Design Manual, 1992 and/or the Concrete Pipe Handbook, 1988 both by the American Concrete Pipe Association which is based on Holl's integration of Boussineq's equations. In addition, the "SAMM" computer program (September 1990), distributed by American Concrete Pipe Association, can also be used for this purpose. The maximum highway wheel loads used for analysis is the maximum of those specified by AASHTO in



"Standard Specification for Highway Bridges" for H20 and HS20 plus impact for a single dual wheel, two (2) passing HS20 trucks and alternate loads in the passing mode. When the depth of cover over the pipe exceeds nine (9) feet, the live load can be neglected.

**I. Reinforced Concrete Pipe (RCP), Reinforced Concrete Sewer Pipe (RCSP), Reinforced Concrete Culvert Pipe Standard Strength (RCCP), Reinforced Concrete Culvert Pipe Extra Strength (RCCPX) Sewer Pipelines.**

- 1) RCP, RCSP, RCCP, and RCCPX are rigid steel reinforced concrete pipes. The strengths for reinforced concrete pipes are specified in the ASTM standards in terms of the ultimate strength (crushing strength) and/or the 0.01 inch crack strength as determined by the Three Edge Bearing (TEB) laboratory test. The 0.01 inch crack strength is the maximum TEB test load supported by a concrete pipe before a crack occurs having a width of 0.01 inch measured at close intervals, throughout a length of at least one foot.

**Use the 0.01 inch crack strength criteria, when evaluating existing reinforced concrete pipes for a change in loading conditions, not the ultimate or crushing strength.**

- 2) RCP strengths to produce a 0.01 inch crack are specified in ASTM standard in one of two ways:
  - a) Three edge bearing strength. The specific load in lb/ft required to produce a 0.01 crack for each individual pipe diameter and class by the TEB test; designated this way in the earlier versions of the ASTM standards. Use the following equation to evaluate the supporting strength of reinforced concrete pipe when specified as above:  

$$\text{TEB to produce 0.01 inch crack} = [(W_1 + W_e) \times FS] \div B_f$$
  - b) D-load strength. Because reinforced concrete pipe was later available in numerous sizes and classes, the pipe strengths were classified by the "D-load" concept in the newer versions of the ASTM standards. The D-load concept provides strength classifications independent of pipe diameter. For reinforced circular pipe the TEB test load in lb/ft to produce the 0.01 inch crack equals the D-load, designated as  $D_{0.01}$ , as indicated in the ASTM standards, multiplied by the nominal inside pipe diameter.

**Example of D-load Strength:**

ASTM C 76, Class IV RCP is manufactured to a D-load of 2000 lb/ft/ft of diameter, with the D-load designated as 2000D, to produce the 0.01 inch crack and 3000 lb/ft/ft of diameter (3000D) to produce the ultimate or crushing load. Therefore, a 48 inch diameter Class IV RCP (ASTM C 76) would have a minimum laboratory strength of (2000 lb/ft/ft  $\times$  4ft) or 8000 lb/ft to produce the 0.01 inch crack and (3000 lb/ft/ft  $\times$  4ft) or 12,000 lb/ft at the ultimate or crushing strength.

Use the following equation, when evaluating the strength of reinforced concrete pipes expressed as D-loads:

$$D_{0.01} = [(\text{Field Load}) \times (\text{Safety Factor})] \div [(\text{Bedding Factor}) \times (\text{Nominal Diameter})]$$

$$D_{0.01} = [(W_1 + W_e) \times FS] \div [(B_f \times D)]$$

Where:

$$D_{0.01} = \text{D-load to produce 0.01 inch crack in lb/ft}$$

$$W_1 = \text{live load on pipe in lb/ft}$$



- $W_e$  = earth load on pipe in lb/ft  
 $B_f$  = bedding factor  
FS = factor of safety, WSSC standard is 1.0 for reinforced concrete pipe when the 0.01 inch crack strength is used as the strength criteria.  
D = nominal inside diameter of circular pipe

3) Information required for analysis.

- a) Determine pipe soil cover from the proposed design and the existing pipe invert from the as-built plans. If there is evidence that the pipe may be at an elevation significantly different than that shown on the as-builts or if the proposed depth of cover is within one (1) foot of the maximum or minimum allowable, then perform test pit(s) to determine the actual elevation of the pipe.
- b) Pipe strength to produce 0.01 inch crack by the TEB method:

- (1) ASTM/ANSI standards. The minimum pipe strength to produce a 0.01 inch crack shall be obtained from the applicable ASTM/ANSI standards for the pipe. Use the ASTM/ANSI standard that was in effect at the time the original pipe was manufactured.
- (2) The applicable pipe specifications (for information only) are as follows, unless otherwise indicated or modified by the applicable Specifications or special provisions for the contract in question:

RCP, RCCP and RCCPX - ASTM C76 Reinforced Concrete Culvert, Storm Drain and Sewer Pipe.

RCSP - ASTM C 75 Reinforced Concrete Sewer Pipe.

(3) Pipe laying condition.

- (a) To determine the actual pipe laying condition and Bedding Factor ( $B_f$ ), see Figure "C", herein. Information on bedding and backfill for the pipe may be found in the Specifications and Standard Details in effect at the time of the pipe installation to determine the laying condition used.
- (b) If the actual laying condition cannot be determined from researching the available contract documents and correspondence contained on microfilm or original construction files, which are available through the WSSC or applicable Specifications and Standard Details or by test pit (i.e. presence and extent of any granular bedding), then use  $B_f = 1.1$  for analysis (class D, flat subgrade with loose backfill).

(4) Type and class of pipe.

- (a) The type of pipe used is typically indicated on the as-built drawings in either the General Notes or on the as-built plans under "As-Built Data". If not indicated on the as-builts, it may be found by researching the available contract documents and correspondence contained on microfilm or original construction files, which are available through WSSC.
- (b) If the type of pipe cannot be determined by researching the contract documents, then it may be possible to determine the type of pipe by going into a manhole or doing a test pit on the run of pipe in question; by visual inspection and verification of type/class by measuring the



pipe wall thickness, outside diameter and/or inside diameter and comparing findings to pipe specifications.

- (c) If an option of several different pipe types is given on contract drawings and there is no indication on the as-builts which was used i.e., in the "As-Built Data", and all other means of determining the type of pipe have proven unsuccessful, then base the analysis upon the weakest pipe.

(5) Earth and truck load.

- (a) Compute the earth loads using the Marston method of design for determining loads on rigid conduits, see ANSI A21.1-1972 or the Concrete Pipe Handbook (1988) for the design method. In addition, the "SAMM" computer program (September 1990), distributed by American Concrete Pipe Association, can also be used for this purpose. In cases where a proposed surcharge fill is being added over an existing pipe which was originally installed under a ditch (trench) condition, consider the negative projection embankment condition to evaluate the earth load on the rigid pipe due to the proposed fill. Determine the earth load on the following parameters:

- [1] Unit weight of soil ( $\gamma$ ).

Assume  $\gamma = 120 \text{ lb/ft}^3$  unless actual soil samples are taken to prove otherwise

- [2] Trench width at top of pipe.

[a] For pipes smaller than 16-inch in diameter, use 30-inch or the trench width found in the applicable Standard Detail or Specification used for construction, whichever is greater.

[b] For 14-inch diameter pipe, use the trench width for a 15-inch pipe indicated in the applicable Standard Detail used for the construction. If evidence of a wider trench width exists, then use the wider trench.

[c] For pipes 16-inch and larger, calculate earth loads assuming original installation was in a transition width trench.

- [3] Assume soil type, ordinary clay, unless actual soil samples are taken to prove otherwise.

- (b) Evaluate truck and superimposed live loads on rigid pipe, using the method presented in the Concrete Pipe Design Manual, 1992 and/or the Concrete Pipe Handbook, 1988 both by the American Concrete Pipe Association which is based on Holl's integration of Boussineq's equations. In addition, the "SAMM" computer program (September 1990), distributed by American Concrete Pipe Association, can also be used for this purpose. The maximum highway wheel load used for analysis is the maximum of those specified by AASHTO in "Standard Specification for Highway Bridges" for H20 and HS20 plus impact for a single dual wheel, two (2) passing HS20 trucks and alternate loads in the passing mode. When the depth of cover over the pipe exceeds nine (9) feet, the live load can be neglected.

**m. Ductile Iron Pipe (DIP) Force Mains.**

- 1) DIP used for sewage force mains are evaluated similar to DIP water pipelines. The required





thickness of DIP is determined by considering internal pressure and trench load separately, both of which are applicable to force mains. Evaluate the proposed change in grade by calculating the required pipe thickness class using ANSI A21.50 (AWWA C150). Compare the required thickness for the proposed condition with the actual pipe class existing.

- 2) Information required for analysis. To evaluate an existing DIP force main for a change in loading conditions the information required using A21.50 is the same as for DIP water pipelines, except that the working and surge pressures are obtained from contract drawings and/or contract specifications.

**n. Cast Iron Pipe (CIP) Force Mains.**

- 1) CIP used for sewage force mains is evaluated similar to CIP water pipelines. The required thickness of CIP is determined by considering internal pressure and trench load combined, both of which are applicable to force mains. Evaluate the proposed change in load by calculating the required pipe thickness class using ASA/USAS A21.1, (AWWA H1). Compare the required thickness for the proposed condition with the actual pipe class existing.
- 2) Information required for analysis. To evaluate an existing CIP force main for a change in loading conditions the information required using ASA/USAS A21.1 is the same as for CIP water pipelines, except that the working and surge pressure are obtained from contract drawings and/or contract specifications.

**o. Polyvinyl Chloride (PVC) SDR 21 Small Diameter Pressure Sewers.**

- 1) Small diameter PVC pressure sewer pipe in accordance with the Specifications, sizes 1 1/4-inch to 4-inch, are used on a limited basis for mainline pressure sewers and pressure sewer house connections as part of a grinder pump sewer system. Due to the limited use of PVC pressure sewer pipe, a detailed method of evaluating the pipe for additional earth loading is not presented in this manual. In general, the method used shall be based upon the Modified Iowa Formula presented in the third edition of the Handbook of PVC Pipe, by the Uni-Bell PVC Pipe Association, limiting the maximum allowable pipe deflection to five (5%) percent and using a deflection lag factor of 1.5.



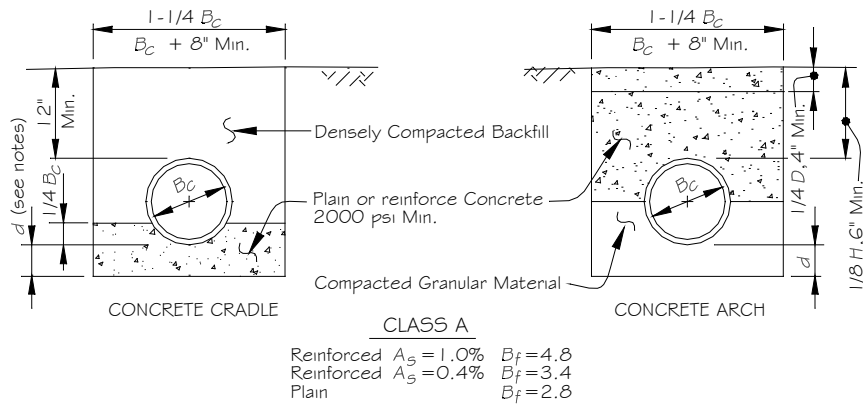

- NOTES:**
1. For Class A Bedding, use  $d$  as depth of concrete below pipe unless otherwise indicated by soil or design conditions.
  2. For Class B and C bedding, subgrade should be excavated or over excavated, if necessary, so a uniform foundation free of protruding rocks may be provided.
  3. Special care may be necessary with Class A bedding or other unyielding foundations to cushion pipe from shock when blasting can be anticipated in the area.

**CLASS A**  
 Reinforced  $A_s = 1.0\%$   $B_f = 4.8$   
 Reinforced  $A_s = 0.4\%$   $B_f = 3.4$   
 Plain  $B_f = 2.8$

- LEGEND**  
 $B_c$  = outside diameter (OD)  
 $H$  = backfill cover above top of pipe  
 $D$  = inside diameter (ID)  
 $d$  = depth of bedding material below pipe  
 $A_s$  = area of transverse steel in the cradle of the arch expressed as a percentage of area of concrete at invert or crown

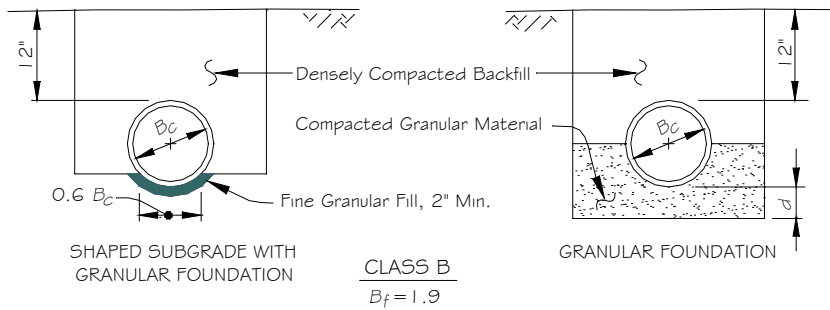

**CLASS B**  
 $B_f = 1.9$

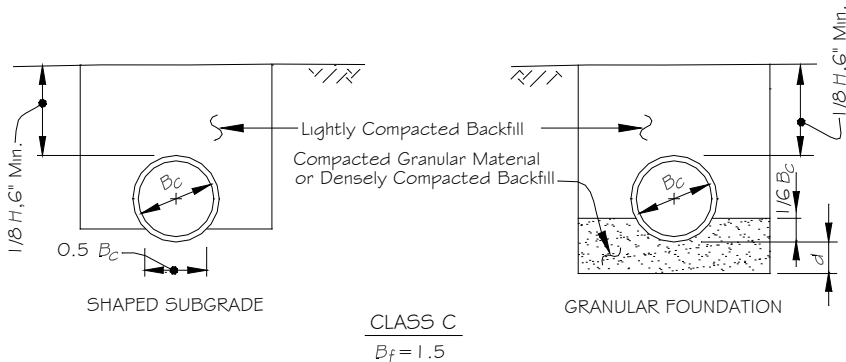

**CLASS C**  
 $B_f = 1.5$

DEPTH OF BEDDING MATERIAL BELOW PIPE	
$D$	$d$ (minimum)
27" and smaller	3"
30" to 60"	4"
66" and larger	6"

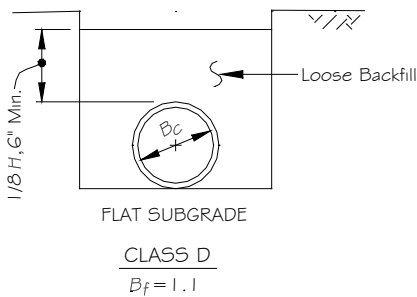

**CLASS D**  
 $B_f = 1.1$

### FIGURE "C"

#### Trench Bedding for Circular Concrete, Clay and Asbestos Cement Pipe

(Figure "C" is copied from the Concrete Pipe Handbook, 1988, Figure 4.39, Trench Bedding - Circular Pipe)



## 12. Related Design and Analysis.

### a. Methods to Increase the Strength of Pipe Due to a Change in Loading Conditions.

- 1) An analysis of proposed loading conditions on existing pipe will sometimes reveal that the pipe is inadequate to handle the load, see Part Three, Section 11 (Loading Analysis of Existing Pipelines). If the existing pipe is found to be inadequate for the proposed loading, several methods are available and permissible by WSSC to mitigate the proposed loading without replacing or relocating the pipe.
- 2) Methods.
  - a) Revise the proposed grading. The first alternative should always be to make every effort to revise the proposed grading or loading to reduce the load on the pipe. Reduce the proposed grade or loading over the existing pipeline so that the pipe is no longer overloaded.
  - b) Upgrade the pipe bedding conditions.
    - (1) As indicated in Part Three, Section 11 (Loading Analysis of Existing Pipelines), the pipe bedding factor or lay condition plays a large part in determining the load carrying capacity of the pipe.
    - (2) Prior to performing a design to upgrade the existing pipe bedding, refer to Part Three, Section 13 (Concrete Encasement, Arches and Cradles), for restrictions on the use of concrete encasements, arches and cradles.
  - (3) Type of pipe.
    - a) For Rigid gravity sewer pipelines, (cast iron, clay, plain concrete, reinforced concrete and asbestos cement pipe) upgrade the bedding to increase the bedding factor and the load carrying capacity as follows:
      - [1] For all diameters, use a concrete cradle according to Standard Detail M/9.0 or concrete arch according to Figure "C". The concrete can be plain or reinforced depending on the bedding factor required, see Figure "C", in Part Three, Section 11 (Loading Analysis of Existing Pipelines), for configuration and corresponding bedding factor for plain and reinforced cradles and arches.
      - [2] For diameters less than 24-inch, re-bed the pipe with higher class granular bedding; see Figure "C", in Part Three, Section 11 (Loading Analysis of Existing Pipelines), for configuration and corresponding bedding factor.
    - b) For Rigid pressure pipe, (prestressed concrete cylinder pipe, cast iron), see rigid gravity sewer pipe except that concrete arches and concrete encasement are not permitted. In order to cradle or re-bed pressure pipe, the pipeline must be depressurized before any excavation around the pipe. WSSC must be contacted to see what time and seasonal restrictions may limit depressurizing the pipeline. In some instances, the pipeline may not be able to be put out of service and this method of increasing load capacity of the pipe may be impossible to implement.



(c) Flexible pipe, (ductile iron, PVC), both gravity and pressure service, provide upgraded laying condition.

[1] **For** DIP, see Part Three, Section 11 (Loading Analysis of Existing Pipelines) and AWWA C150 for the relationship between lay condition and pipe load capacity and derive the lay condition that will allow the pipe to carry the proposed additional load.

[2] **For** PVC pipe, the lay condition (type of soil and degree of compaction) must be modified to provide a modulus of soil reaction,  $E'$ , that will allow the pipe to carry the load. **For the Modified Iowa Formula, see PVCPIP Association- Handbook of PVC.**

c) Relocate or replace the pipe using a pipe material or pipe class capable of handling the additional load.

**b. Field Investigations to Verify Assumptions Made in Analysis.**

1) Assumptions.

a) Part Three, Section 11 (Loading Analysis of Existing Pipelines), has established criteria and procedures for evaluating the impact of changing the grade or loading over existing water and sewer pipelines. The results of these evaluations will indicate whether a pipeline, or section of pipeline, is adequate to handle existing and additional proposed loading. Certain assumptions are made in these evaluations.

b) The following assumptions are typically made from the best available record information: Amount of existing earth cover over the pipe; whether or not pipe bedding was used and the extent of bedding; whether or not the pipe was installed in a wide or narrow trench, Surge allowance for waterlines and forcemains; pipe material and class; unit weight and type of soil. The assumptions for these parameters provide for a conservative, expeditious analysis.

2) Field investigations. Occasionally, the need may arise for a more exact pipe loading analysis. Such needs may arise, for example, when the cost to relocate an existing inadequate pipe due to excess proposed fill is prohibitive. In such cases, the developer, highway authority, WSSC, etc., may propose a field, or other program to verify the assumptions made in the analysis.

a) Example case to verify existing earth cover. The amount of proposed additional fill in conjunction with existing earth cover may be shown in an analysis to overload an existing pipe. The relocation of the pipe may be extensive, disruptive, and expensive. In doing the analysis to see whether the pipe is overloaded, the amount of existing cover over the pipe is generally taken from the as-built drawings. The accuracy of the as-builts, however, is questionable in some cases. If the as-builts show more cover than actually exists, then the analysis may be more conservative than necessitated by actual conditions.

Therefore, in the project may recommend that test pits be done to verify actual cover. If it is found that the existing pipeline was built at a higher elevation than shown on the as-builts (and therefore has less cover than originally expected), the pipe may actually be adequate for the proposed additional fill and not need be relocated.



- b) Example case to verify existing pipe bedding. Another example would be where a pipe analysis makes the assumption that the pipe was installed in a flat-bottom trench. This assumption may minimize the earth loading capacity of the pipe. As in the previous example, if the pipe analysis assuming a flat-bottom trench shows additional cover will overload the pipe, relocation may be required. Again, the required relocation may be expensive, extensive and disruptive. **Designer** may recommend that test pits be performed to confirm actual bedding conditions **during design**. Better bedding will increase the load-carrying capacity of the pipe and possibly eliminate the need for relocation.
- 3) For methods to increase the load carrying capacity of the pipe without having to relocate or replace, see Methods to Increase the Strength of Pipe Due to a Change in Loading Conditions, in this section.

**c. Necessity for Pipeline Relocations.**

- 1) The design of water and sewer pipeline relocations can be costly and lengthy. They are typically more involved than standard designs due to the often limited allowable shutdown time (usually eight (8) hours) for the existing pipeline. Special designs are often required for items such as special thrust restraint and suggested construction sequencing in order to maintain service or minimize disruption to existing services. In addition, construction of the relocation requires additional coordination and construction efforts resulting in higher construction costs.
- 2) Situations which may result in relocations including the design of new roads, storm drains, road improvements, new developments, etc., should be closely coordinated with existing WSSC water and sewer pipelines during the design of these facilities. Whenever possible, consider alternate facility designs that will eliminate the need for water or sewer pipeline relocation. The following situations may require relocation of an existing pipeline:
  - a) Proposed stormwater management pond too close to an existing WSSC pipeline.
  - b) Proposed grading that adds fill that overloads the existing pipe.
  - c) Proposed grading that removes cover over an existing pipe to the extent it may be damaged by construction equipment, impact and point loading, etc. For minimum permissible earth cover over water pipelines see Part One, Section 4 (Selection of Pipe Material) and Section 11 (Vertical Alignment - Profiles), and over sewer pipelines, see Part Two, Section 3, (Selection of Pipelines Material - Gravity Sewers) and Section 8 (Vertical Alignment - Profiles).
  - d) Proposed placement of a new structure too close to an existing pipeline. The proposed structure location may be such that the existing pipeline will fall within the influence of the new footing or the new structure may be placed such that maintenance of the existing pipeline is too difficult.
  - e) Conflicts with proposed storm drain piping and structures.
  - f) Conflicts with new roads, road improvements, or new developments.



**d. Methods to Protect Pipelines During Construction.**

- 1) Often new construction or grading will take place over or adjacent to existing pipelines. When this occurs, it may be necessary to add requirements under the contract documents to protect existing WSSC facilities. The pipeline may be damaged during construction operations by circumstances such as:
  - a) Overloading the pipe by crossing over it with construction vehicles, producing a live load greater than AASHTO H20/HS20.
  - b) Overloading the pipe by stockpiling soils or other materials above the pipe.
  - c) Overloading the pipe by crossing it with heavy construction equipment at locations where the soil has been cut to less than the minimum allowable.
  - d) The location of the existing thrust blocking and the passive soil wedge resisting the block's movement may have to be staked in the field, if the contractor's work might possibly adversely impact the block's stability.
- 2) Examples.
  - a) A WSSC right of way containing a 96-inch water pipeline goes through a site on which a developer is going to build a residential community. The developer's grading plan requires him to move large amounts of fill from one part of the site to another using heavy earth moving equipment driving over the existing 96-inch water pipeline. The WSSC finds the pipe is almost overloaded without the additional construction loads. The pipeline needs to be protected during construction. Methods of protection that should be considered include:
    - (1) Designate certain locations as crossing points over the existing pipeline. To keep vehicular and equipment traffic off the pipeline at other locations, the right of way can be fenced off.
    - (2) At the designated crossing point, provide a means of crossing the pipeline without overloading it. This might include use of a temporary bridge over the pipe. If the bridge is used, the bridge abutments would have to be placed so they don't transfer any load to the pipe. In some cases, augered caissons (augered to below the pipe invert) have been used for abutments to support the bridge. Timber mats may be used to spread a load, however provide calculations to show that the weight of the heaviest vehicle, when crossing the mat, is reduced to a load no greater than that produced by an AASHTO H20/HS20 configuration.
  - b) To avoid overloading a pipe due to stockpiling of material, provide notes indicating the minimum clearances between the toe of the stockpile and the centerline of the existing pipe.
  - c) For locations where the soil cover will be cut below the minimum allowable during construction, the method of protection that should be considered includes restricting all work above the pipeline to be performed using manual equipment and restricting construction vehicles from working close to the pipe until adequate soil cover is placed manually.



**e. Submittal Information Required for the Proposed Grading over WSSC Pipelines.**

- 1) Submit the following information.
  - a) Scaled profile of the proposed grading drawn on the as-built plans of the existing pipeline.
  - b) If the scaled profile cannot be drawn on a copy of the as-built plans, then the existing pipeline invert, with stations and elevations should be transferred to a new profile.
  - c) Information about the existing pipeline.
    - (1) Type of existing pipe material and type of existing pipe joint (mechanical joint, push-on joint, etc.).
    - (2) Strength class of the existing pipeline.
    - (3) Internal pressure of the existing pipeline.
    - (4) Pipe bedding information on the existing pipeline.
    - (5) If the above information is not on the as-built drawings, it may be found by researching the available contract documents and correspondence contained on microfilm or original construction files, which is available through the WSSC.
      - (a) WSSC Construction Files must be retrieved and reviewed to extract the information from delivery tickets, correspondence, specifications, inspection reports, or other contract documents that may be in these files.
      - (b) Where Prestressed Concrete Cylinder Pipe (PCCP) was installed, the pipe specification, design curves and lay schedule must be retrieved because PCCP is designed and manufactured specifically for particular site conditions.



### 13. Concrete Encasement, Arches and Cradles.

#### a. Concrete Encasement.

- 1) Concrete encasement for gravity sewer pipelines to upgrade the pipe bedding.
  - a) Proposed gravity sewers. The use of concrete encasement for the purpose of upgrading the bedding to increase the load carrying capacity of the pipe is not permitted. The appropriate class and type of pipe shall be used in conjunction with the standard bedding for the pipe as indicated in the Specifications and Standard Details.
  - b) Existing gravity sewers. Concrete encasement is acceptable within the limitations noted in Part Three, Section 12 (Related Analysis and Design) to increase the bedding factor to allow the pipe to withstand higher loading. Submit computations and details for review. The method of analysis of an existing sewer for a proposed increase in soil cover or live loading to be in accordance with Part Three, Section 11 (Loading Analysis of Existing Pipelines).
- 2) Water and Sewer Pressure Pipelines. Concrete encasement is not permitted for use on any water and sewer pressure pipelines.
- 3) The allowable sewer pipeline materials that can be used with concrete encasement include: reinforced and unreinforced concrete pipe, cast iron soil pipe, vitrified clay pipe and asbestos cement pipe, **and ductile iron pipe**, see Standard Detail M/9.0 for details.
- 4) For requirements for concrete encasement of gravity sewer pipelines for protection of water pipelines against contamination, see Part Three, Section 3 (Pipeline Crossings and Clearances).
- 5) Concrete encasement of sewer pipelines in special cases not covered above will be considered on a case by case basis.
- 6) Encasement of pipelines at stream crossings is not permitted.

#### b. Concrete Arches.

- 1) Proposed gravity sewer pipelines. The use of concrete arches over proposed gravity sewers for the purpose of upgrading the bedding to increase the load carrying capacity of the pipe is not permitted. Design the sewer pipeline with the appropriate class and type of pipe in conjunction with the standard bedding for the pipe as indicated in the Specifications and Standard Details.
- 2) Existing gravity sewer pipelines. Concrete arches may be used as an alternative on existing gravity sewer pipelines for the purpose of upgrading the bedding factor to increase the load carrying capacity. A concrete arch may be suitable when it is preferable not to dig under an existing gravity sewer pipe to avoid disturbing the pipe. The method of analyzing the existing sewer for a proposed increase in soil cover or live loading is to be in accordance with Part Three, Section 12 (Related Analysis and Design). Submit computations and details for approval.
- 3) Water and Sewer Pressure Pipelines. Concrete arches are not permitted for use on any water and sewer pressure pipelines.





**c. Concrete Cradles.**

- 1) Existing water pipelines. Under special circumstances, only when approved and installed under strict guidelines, concrete cradles can be used to upgrade the bedding under existing water pipelines to increase the load carrying capacity. Submit computations and design details **to WSSC for approval.**
- 2) Existing sewer pipelines. Under special circumstances, only when approved and installed under strict guidelines, concrete cradles can be used to upgrade the bedding under existing force mains or pressure sewers to increase the load carrying capacity. Submit computations and design details **to WSSC for approval.**
- 3) For example, a special circumstance for consideration might include a short length of large diameter existing pipeline which will be overloaded by proposed work, and relocation or replacement of the section of pipe may be cost prohibitive.



## 14. Anchoring Pipes on Steep Slopes.

### a. General.

- 1) Pipelines designed on steep slopes with a grade of twenty (20%) percent or greater require concrete anchors. For material and other requirements for pipes on steep slopes, see Part Two, Section 15, (Pipe Slope and Manhole Distance) and Part Two, Section 9 (Vertical Alignment - Pipe Slope).

### b. Design Requirements.

- 1) Pipe Slopes twenty (20%) percent to under fifty (50%) percent.
  - a) Concrete anchors for DIP and AWWA C900/905 PVC pipe, 24-inch diameter and smaller, are to be according to the Standard Detail M/4.0.
  - b) On profile show the concrete anchor and the spacing in accordance with Standard Detail M/4.0. Space the anchors depending on the pipe slope. Determine the pipe slope and show the stations at which the anchors are to be located on the pipeline, see Sketch "CC".

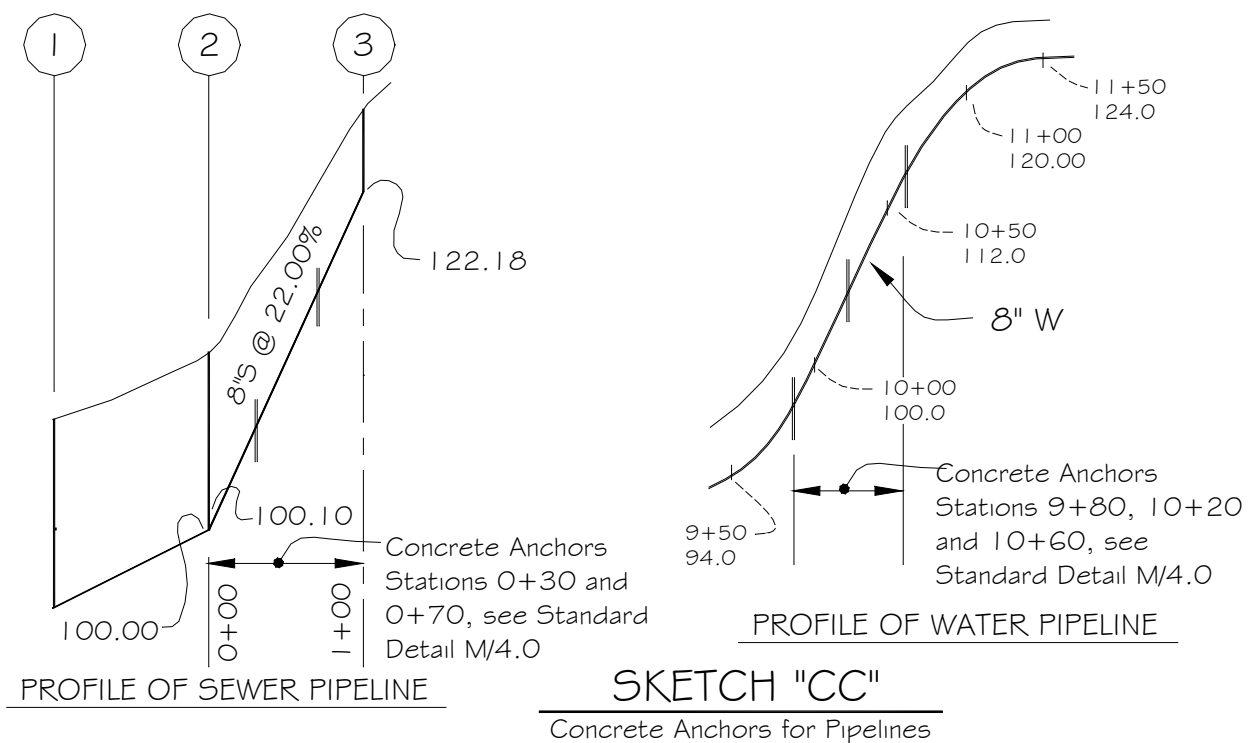

- c) For concrete anchors for 24-inch diameter and smaller pipe other than DIP and AWWA C900/905, and all pipes greater than 24-inch diameter, special design is required. Provide details on the drawings and submit calculations.

- 2) Pipe slopes fifty (50%) percent and greater. Special design is required, provide details on the drawings and submit calculations.



## 15. Pipe Joint Clearances within Structures.

### a. General.

- 1) The following establishes the minimum distance that a pipe joint can be located from the walls of structures and buildings for both buried piping and piping exposed in a building or structure to facilitate installation and future maintenance. Pipe joint manufacturers may recommend clearances smaller than those stated in this section, but the clearances indicated below must be used for the design. Do not design pipe joints with stud bolts; base the designs on joints using standard bolts with nuts.

### b. Minimum Distances for Flanged Joints.

- 1) Straight wall. Provide a minimum distance of 12-inches from the face of the flange to the face of the wall, see Sketch "DD".
- 2) Circular wall. Provide a minimum distance of 12-inches, measure the distance from the closest face of the wall to closest face of the flange joint, see Sketch "DD".

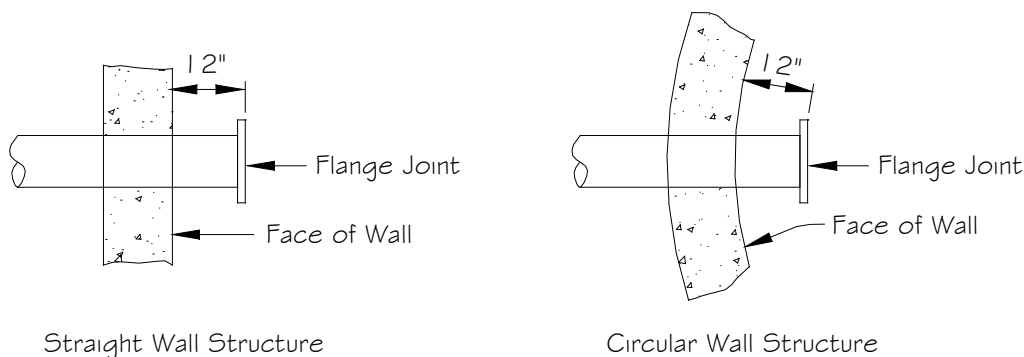

SKETCH "DD"

Location of Flanged Joint at Structures

### c. Minimum Distances for Mechanical, Push-on and Plain End Joints.

- 1) Straight wall. Provide a minimum distance of 12- inches from the face of the bell to the face of the wall, see Sketch "EE".
- 2) Circular wall. Provide a minimum distance of 12-inches, measure the distance from the closest face of the wall to the closest face of the bell, typical to Sketch "EE".



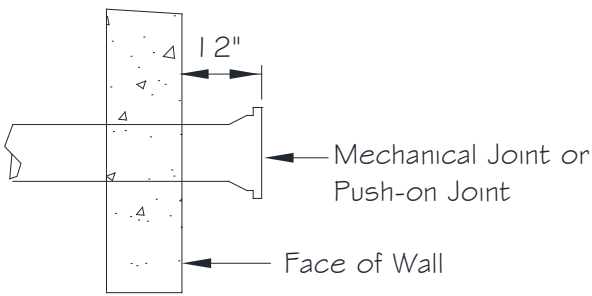

Mechanical or Push-on Joints

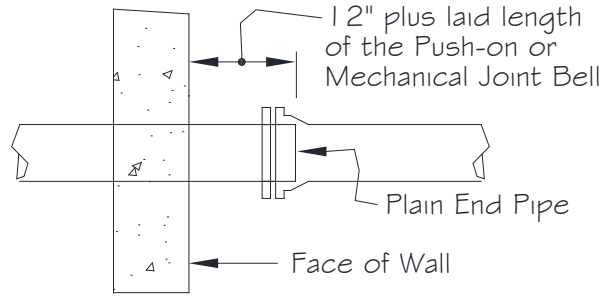

Plain End Pipe for Mechanical or Push-on Joints

## SKETCH "EE"

Location of Mechanical, Push-on or Plain End Joints at Structures



## 16. Design of Pipeline Structures.

### a. General.

- 1) The following guidelines are for the design of structures for water and sewer pipelines including structural concrete and miscellaneous metals design. These include cast in place or precast concrete structures such as valve vaults, manholes, junction chambers, air release/vacuum valve vaults, metering vaults, entry port vaults, etc. Whenever possible, provide concrete structures **sized and designed** in accordance with the **latest WSSC Standard Details**. Structures other than those shown in the Standard Details are considered special design and will require the structure to be designed and shown on the drawings using the guidelines in this section. For all special designs, provide structural calculations performed, signed and sealed by a Professional Engineer registered in the State of Maryland.
- 2) **All access devices shall be designed in compliance with the latest OSHA or IBC regulations.**

### b. Abbreviations for References.

AASHTO	American Association of State Highway and Transportation Officials.
ACI	American Concrete Institute.
AISC	American Institute of Steel Construction, Inc.
ASTM	American Society for Testing and Materials.
<b>IBC</b>	<b>International Building Code</b>
<b>OSHA</b>	<b>Occupational Safety &amp; Health Administration</b>

### c. Design Loads for Pipeline Structures.

- 1) Dead loads:
  - a) Soil: Use actual soil parameters from Soil Report. See Soil Data or Soil Report, Part Three, Section 20 (Geotechnical and Corrosion Submittals). If Soil Report is not available, use a soil unit weight of 120 lb/ft<sup>3</sup>.
  - b) Water Table: Assume 4'-0" below ground surface if no other information is available.
  - c) Concrete: 150 lb/ft<sup>3</sup>.
  - d) Aluminum: **170** lb/ft<sup>3</sup>.
- 2) Hydrostatic: 62.4 lb/ft<sup>3</sup>.
- 3) Live loads: 300 lb/ft<sup>2</sup> minimum.
- 4) Traffic loads: AASHTO H20 wheel load with appropriate impact factor.
- 5) Surcharge load: Assume 2 feet of earth cover, unless other information is available.
- 6) Lifting loads: Design precast structures for lifting loads.



- 7) If the structure is located within the limits of the one hundred (100) year flood plain, use the appropriate loading due to the one hundred (100) year flood.

**d. Design Criteria (Codes and Standards) for Pipeline Structures.**

- 1) Design pipeline structures according to the **latest editions of the** following codes and standards:
  - a) **IBC (International Building Code)**
  - b) ASTM C890 (Standard Practice For Minimum Structural Design Loading for Monolithic or Sectional Precast Concrete Water and Wastewater Structures).
  - c) ACI 318 (Building Code Requirements for Reinforced Concrete Structures).
  - d) ACI 350 (Environmental Engineering Concrete Structures).
  - e) AISC Code (Specification for the Design, Fabrication and Erection of Structural Steel Buildings).
  - f) AASHTO Code.
  - g) Aluminum Association (Aluminum Design Manual).
  - h) OSHA (Occupational Safety & Health Administration Safety Guidelines and Standards)**

**e. Concrete Structures.**

- 1) Design methods. Use one of the following two methods for the structural design of reinforced concrete cast in place and precast structures: Strength Design Method and Working Stress Design Method (Alternate Design Method, ACI 318, Appendix A). Use the special limitations for both methods, in accordance with ACI 350, Environmental Engineering Concrete Structures. These methods are described in detail in ACI 318.
- 2) Design of the structures. When the design requires a structure, if possible use the structures provided in the **latest WSSC** Standard Details. If a special design structure is required, provide a design for a cast in place structure, with the option for the contractor to submit a design for a precast structure, in accordance with the Specifications.
- 3) Buoyancy design. When groundwater is present, consider the effects of flotation for below ground structures. Size the structure with a **minimum** flotation safety factor of 1.1. Assume in the flotation calculations that the structure is empty; the top slab is removed, and neglects the weight of any equipment, piping, etc.
- 4) Concrete strength. Use the following concrete compressive strengths ( $f'_c$ ) when designing concrete structures. Indicate the concrete compressive strengths on the drawings.
  - a) Cast in place structures:  $f'_c = 4000$  psi @ 28 days.
  - b) Precast structures:  $f'_c = 5000$  psi @ 28 days.



- 5) Steel reinforcement. Use ASTM A615, grade 60 (yield strength,  $f_y = 60,000$  psi). Indicate the reinforcing bar size and spacing on the drawings.
- 6) Precast lifting inserts. Design the lifting inserts for precast structures/members for four (4) times the maximum load transmitted to the inserts.
- 7) Structure components. Design underground concrete structures for the minimum loads indicated in ASTM C890 as modified in this section and include the following load combinations:

Case 1: Minimum Cover of 1'-0" and H20 loading with 30% impact.

Case 2: Cover of 5'-0" with 2'-0" surcharge.

Consider water table of 4'-0" below for both Cases unless other information available.

- a) Top slab design. Consider the cumulative effect of the dead loads including the weight of earth backfill, access openings/covers, loads due to equipment if any lifting eye bolts or hooks are provided on the underside of the slab, etc. and AASHTO H20 live load **with appropriate impact factor**, unless the top slab is located in a confined area or at least one (1) foot above the ground surface. Also see Design Loads for Pipeline Structures, in this section.

Note: A confined area is defined as an area enclosed by a fence or an area that will have absolutely no H20 loading in the future. For confined areas, use 300 lb/ft<sup>2</sup> live load in lieu of H20 loading.

- (1) Provide removable top slabs for either the entire slab (preferable) or portions of the slab to allow the **replacement** of the largest object in the vault.
- (2) If the top slab is fixed with the ratio of each side less than two (2), analyze as a two-way slab, otherwise, analyze as a simply supported one-way slab.
- (3) Span length: Center of wall (support) to center of wall (support).
- (4) Traffic load: Design in accordance with AASHTO.
- (5) When depth of fill is less than 2 feet, use exact method considering wheel contact area, or simplified formulas for bending moments as per AASHTO.
- (6) When depth of fill is two (2) feet or more, consider concentrated load or loads as uniformly distributed over a square area with the sides equal to 1-3/4 times the depth of fill, see AASHTO Specifications, Section 6, for more information.
- (7) Removable slab: Limit size of slab to a maximum of 15,000 lbs and provide off-set key at edge to prevent movement.
- (8) Slab openings: Use net cross section of **the** slab for shear and bending moment **analysis**. **Provide additional rebar around the slab openings per WSSC Standard Details.**



- b) **Wall design.** Consider the use of standard vault sizes as per Section.16.a. (1). Include the cumulative effects of the maximum external hydrostatic load, maximum lateral earth pressure and lateral surcharge load. Base the unit lateral earth pressure upon information obtained from the Soil Report, see Part Three, Section 20 (Geotechnical and Corrosion Review Submittals).
- (1) When soil borings are not available, assume the at rest earth pressure coefficient  $K_0 = 0.5$ . Design the walls for ground water pressure in addition to the earth pressure when indicated in the Soil Report. When the Soil Data or Soil Report is not available, assume the ground water level is at four (4) feet below the surface, unless the structure is located in a flood plain area. In this case, design the structure for flooded conditions with an allowable stress increase of 1.33.
  - (2) When a valve vault is designed as a thrust vault, design the walls for the full closed valve thrust force and size the vault against sliding with a minimum safety factor of 1.5.
  - (3) Where traffic can come within a horizontal distance from the structure equal to one half the depth of the structure, apply a lateral surcharge pressure to the walls. In most cases, the live load can be converted to an equivalent depth of earth fill, and the horizontal pressure computed on the basis of the earth depth. The effect of this surcharge can be considered as a rectangular loading diagram for the full height of the wall, up to a depth of eight (8) feet below grade.
  - (4) Additional wall design requirements.
    - (a) Precast vaults shall be designed as a one-piece unit opened with the top and with the bottom slab. Two-piece unit vault with upper/top O-shape section and lower/bottom sections may be designed only for big vaults as an exception due to special conditions of transportation and lifting /installation weight limitations.
    - (b) For the one-piece vault, consider:
      - i) For a wall with a width to height ratio between .5 and 2 – top of the wall hinged and three (3) sides fixed.
      - ii) For other ratios, consider a one way slab in short direction.
    - (c) For the two-piece vault, design of the upper piece wall shall be as a one-way element (horizontal) and design of the lower piece walls shall be as indicated above in 4(b).
    - (d) Soil load to be trapezoidal distribution as recommended in the Soil Report.
    - (e) If the vault is to be designed for thrust, consider the thrust force as either: effective width of concentrated thrust force or other accurate method such as finite element analysis, etc.
    - (f) If the vault is to be designed as a thrust vault, consider the punching shear due to the thrust force.
    - (g) Provide additional rebars around all penetrations per WSSC Standard Details. Confirm sufficient header depth above wall penetrations to accommodate main and additional wall





reinforcement and provide sufficient rebar spacing and cover as per ACI 350.

- (h) No shear keys at horizontal joints in concrete structures, unless there is an extraordinary reason; submit to WSSC for review and approval. Instead provide shear reinforcement, if required. Construction joint between the base slab and walls to be located at the junction of the walls and base slab.
- c) Bottom slab. Precast units shall have walls integrated with bottom slab. Cast-in-place structures shall have adequate dowels per design.
  - (1) Design as fixed end with 2-way slab if ratio between two sides is less than two (2), otherwise consider one-way slab. Consider all live loads and dead loads as a uniform load.
  - (2) Detail sump pit per WSSC Standard Details. Provide additional rebars around openings.

**f. Miscellaneous Metals.**

- 1) Steel structures. The Working Stress Design Method by the AISC manual is preferable, but Load and Resistance Factor Design (LRFD) may be used.
  - a) Gratings. Design or select gratings for 300 lb/ft<sup>2</sup> loading, unless given other specific loading conditions or a higher load is expected. Show the span direction of the grating bearing bars on the drawings. Follow the manufacturer's recommendations and limit the deflection to 1/4" or span length L/360, whichever is smaller, at the design load. Provide removable sections with anchoring devices.
  - b) Frame Structures. Steel frames, wide flange, angle or channel members and designed for the load tributary area. Allowable stress to be in accordance with AISC manual.
  - c) Hatches. Design hatches in open areas (outside of road) or areas that are not subjected to high density traffic for H20 loading. Design hatches located in confined areas or where the hatch is at least one (1) foot above ground, for 300 lb/ft<sup>2</sup>. Limit the maximum deflection to L/150. Use frame and cover in lieu of hatches when opening is located in existing or future roadways or location is subjected to high density traffic.
    - (1) When hatches are provided, design the hatch drain as follows:
      - (a) When the top slab is set above grade, design the hatch drain to discharge outside the vault.
      - (b) When the hatch is set to grade, design the hatch drain to discharge in the vault.
  - d) Pipe thrust restraint system. Design tie rods for the full thrust tensile force. Design lugs or thrust rings for the full thrust force and shear. Bending moment and deflection must also be checked. Check stress on the pipe due to welded-on thrust rings or lugs.
- 2) Aluminum Structures.
  - a) Gratings. Design or select gratings for 300 lb/ft<sup>2</sup> loading, unless given other specific loading conditions or a higher load is expected. Show the span direction of the grating bearing bars on the drawings. Follow the manufacturer's recommendations and limit the deflection to 1/4" or span length L/360, whichever is smaller, at the design load. Provide removable sections with



- grating fasteners (saddle clips, weld lugs, etc.) per WSSC Standard Details M/22.0 and M/22.1.**
- b) **Frames.** Aluminum frames are to be wide flange, angle or channel members and designed for the load tributary area. Allowable stress of aluminum members to be in accordance with the Aluminum Association Specifications. Design connections **using stainless steel bolts** and provide details on the drawings. Design anchor bolts or expansion bolts embedded in concrete for shear and tension forces. **Provide anchoring devices per WSSC Standard Details M/22.1**
- c) **Hatches.** Design hatches located in open areas (outside **the roadway**) not subjected to high density traffic for an H20 loading. Design hatches located in confined areas or at least one (1) foot above ground, for 300 lb/ft<sup>2</sup>. Limit the maximum deflection to L/150. Do not use hatches on roadway locations subject to high density traffic.
- (1) When hatches are provided, design the hatch drain as follows:
- (a) When the top slab is set above grade, design the hatch drain to discharge outside the vault.
- (b) When the hatch is set to grade, design the hatch drain to discharge in the vault.
- d) **Ladders.** Design ladders for a 300 lb concentrated load at the middle of the ladder rung **per OSHA Standards**. Use solid bar rungs with serrated surface and a minimum of 3/8" thick stringer. Provide a bracket support for the stringers at four (4) foot spacing; see Standard Detail M/16.0. **Use ladder extension as applicable per WSSC Standard. Detail M/16.1.**



## 17. Evaluation of Existing Pipeline Structures.

### a. General.

- 1) Evaluate the impact on existing structures of any changes to existing loading or dimensions, **any** relocation or upgrading of roads, **based on** the strength and existing condition of the structure.
- 2) **Evaluate the existing conditions of the structure for compliance with the current OSHA or IBC regulations.**

### b. Analysis.

- 1) Review the affected structures using the as-built drawings and by researching the available contract documents and correspondence contained on microfilm or in original construction files, which are available through WSSC. Check for surcharge loading, H20 traffic loading, and other appropriate structural loads applicable to the structure as indicated in Part Three, Section 16 (Design of Pipeline Structures). Also, provide analysis using the same criteria for any contemplated rehabilitation. If available, check Standard Details in effect at the time the structure was built (for example, manhole wall thickness for deep manholes).
- 2) **Review existing conditions of the structure for compliance with the current OSHA or IBC regulations. Analyze feasibility and note recommendation to bring existing structure up to the current standards.**

### c. Procedure.

- 1) Provide primary evaluation of the condition of the structure by visual inspection, if accessible. If existing structure appears to be structurally strained due to evidence of cracks, uneven settlement or corrosion of structural elements, evaluate each element separately for the proposed loading. Evaluate sewerage structures for infiltration, see Part Two, Section 11 (Design of Structures) and consult with WSSC.
- 2) **Provide evaluation of the accessibility conditions of the structure by visual inspection for compliance with the current OSHA or IBC regulations. Evaluate entrance devices, ladders, existing walking and operation distances, etc.**

### d. Guidelines and References for Evaluating Existing Structures.

- 1) Abbreviations for References.

AASHTO	American Association of State Highway and Transportation Officials.
ACI	American Concrete Institute.
AREA	American Railway Engineering Association.
AWS	American Welding Society.
OSHA	<b>Occupational Safety &amp; Health Administration</b>

- 2) Concrete Structures.

- a) ACI 318, Chapter 20, "Strength evaluation of existing structures."



- b) ACI 201.1R-68 (revised 1984), "Guide for making a condition survey of concrete in service."
- c) ACI 201.3R-86, "Guide for making a condition survey of concrete pavements."
- d) ACI 210R-87, "Erosion of concrete in hydraulic structures."
- e) ACI 207.3R-79 (revised 1985), "Practices for evaluation of concrete in existing massive structures for service conditions."
- f) Secondary References.
  - (1) AREA, Chapter 8-21-85, "Inspection of concrete and masonry structures."
  - (2) Asphalt Institute, Technical Bulletins TB1, TB2, TB3 and TB4, "Asphalt overlays over concrete."
  - (3) Department of the Army, US Army Corps of Engineers, Engineering Manual No. 1110-2-2002, "Engineering and Design - Evaluation and Repair of Concrete Structures."
- 3) Steel and Metal Elements.
  - a) Evaluate existing structural members under actual field conditions.
  - b) Evaluate welded joints by visual inspection, unless other methods are necessary.
  - c) **Perform** strength evaluation in conformance with appropriate standards indicated in Part Three, Section 16 (Design of Pipeline Structures).
- 4) Plastics and Wood.
  - a) Replace deteriorated elements.
- 5) Other References.
  - a) ASCE, "Guidelines for structural condition assessment of existing buildings."
  - b) US Army Corps of Engineers, "The REMR (repair, evaluation, maintenance, rehabilitation) Notebook."
  - c) AWS Welding Handbook.
  - d) Federal Standards:
    - (1) TM-5-818-5, "Pavement evaluation for frost condition."
    - (2) BSS-58, "State of the art of structural test methods for walls, floors, roofs and complete buildings", November 1974.
    - (3) Technical Note 1247, "Review of non-destructive evaluation methods applicable construction materials and structures", June 1988.



e) **Safety and Accessibility Regulations:**

- (1) OSHA “Occupational Safety & Health Administration Guidelines”
- (2) IBC “ International Building Code”

**e. Evaluation of Structural Components.**

- 1) **Perform structural** evaluation for vaults to include, but not limited to the following: walls-concrete/masonry, bottom slab, top slab, structural beams and seating, ladder rungs, manhole covers and hatches, lifting hooks, and pipe supports.
- 2) **Perform structural** for manholes to include, but not limited to the following: walls, manhole frame and cover, ladder and manhole steps, pipe connections, benches, joints and brick mortar.
- 3) **Perform structural** evaluation for tunnels to include, but not limited to the following: bulkheads, access manholes, casing pipes (RCP and Steel) and liner plates.



**18. Temporary Construction Support Criteria.****a. General.**

- 1) The guidelines below present WSSC's policy for the temporary excavation support of a WSSC system or facility or any structure or facility which WSSC has interest in protecting during the course of a WSSC construction project.

**b. Guidelines.**

- 1) When an excavation is contiguous to a WSSC system or facility or any structure which WSSC has considerable interest in protecting, furnish the excavation support design as directed by WSSC as part of the contract documents. In all other cases, it is the responsibility of the Contractor to secure the services of a Professional Engineer registered in the State of Maryland to prepare and submit the design of the support for information only to WSSC prior to the construction.



## **19. Geotechnical Considerations for Pipeline Alignments.**

### **a. General.**

- 1) This section discusses the geotechnical features that should be considered to obtain the most trouble free pipeline alignment. The selection of a pipeline alignment is typically based upon the requirements of the project, the physical constraints of the site and economics. Also consider the following geotechnical features during the selection of the alignment.

### **b. Geology of the Site.**

- 1) The geology of the site can significantly affect the cost of the project. If rock is encountered, not only do excavation costs increase, but special pipe bedding material will also be required. The alignment should be chosen to minimize the amount of rock encountered. The geologic map of Maryland prepared by the US Geological Survey may be used to obtain information on the geologic settings of the proposed alignment.

### **c. Soil Conditions.**

- 1) The soil conditions affect both the design and construction of pipelines. For flexible pipe, such as PVC, the pipe supporting strength is partially provided by the soil side support. If the soil is very soft, the pipe class or pipe type should be upgraded to compensate for the weak soil. In marshy areas, special consideration should be given to create a stable subgrade condition. Information from soil borings, existing construction projects in the vicinity of the proposed alignment and the Soil Survey Reports for Montgomery and Prince George's Counties prepared by the US Department of Agriculture may be used to obtain information on the existing soil conditions.
- 2) Construction costs are also greatly affected by the soil conditions. They not only affect the excavation process, but also affect the type of temporary support needed for the trench walls. For soils with no or short stand-up times, some form of support would be needed which adds to the cost of the project.

### **d. Groundwater Conditions.**

- 1) Groundwater within the pipe zone almost always increases construction costs. Groundwater control during the construction phase requires the use of extra equipment and results in longer construction times. Areas with high groundwater should be avoided, if possible.

### **e. Crossing of Highways and Railroads Requiring Tunneling.**

- 1) Crossing under major highways and railroads usually requires tunneling. The cost of the project substantially increases when tunneling is required. The alignment should be chosen to minimize the need for tunneling. If a tunnel is required, it should be located in an area where the geologic soils and groundwater conditions are favorable, see Part Three, Section 25 (Tunnels), and Section 26 (Tunnel Design Criteria). All tunnel requirements and permit issues of the authority having jurisdiction over the highway or railroad should be considered.



**f. Crossing of Environmentally Sensitive Areas.**

- 1) Pipelines going through environmentally sensitive areas such as streams, lakes and wetlands require special attention; see Part Three, Section 23 (Pipeline Design in Wetlands). Not only are complex environmental design and construction issues involved, but also permitting issues and complying with different agency regulations also create complications. Every effort should be made to avoid these areas. A thorough review and analysis of crossing these areas should be done during the conceptual design to minimize disruptions and surprises during construction. Resolution of environmental issues is often a very slow process. Therefore, these issues should be given top priority during the early stages of design.

**g. Crossing Contaminated Areas.**

- 1) To the extent practical, align the pipeline to avoid contaminated areas. Soil and groundwater contamination can result in health, safety, technical, and legal complications. Investigation and resolution of these issues is often complex and lengthy. Therefore, the possibility of site contamination should be examined during the preliminary alignment stage. See Part Three, Section 24 (Pipelines Crossing Contaminated Areas) for detailed information on investigation and design requirements.

**h. Proximity to Existing Structures and Other Utilities.**

- 1) Proximity to existing structures or formations, such as a natural or man-made slopes, see Part Three, Section 22 (Slope Stability), retaining walls, buildings and other utilities should be considered during the selection of the pipeline alignment, see Part Three, Section 3 (Pipeline Crossings and Clearances). A buffer zone is needed to minimize the impact of the trench excavation on the integrity of the structure and to facilitate future maintenance, see Part Three, Section 18 (Temporary Construction Support Criteria). Early coordination with PEPCO, Verizon, BG&E, and gas and oil companies will minimize possible conflicts which may delay the project.

**i. Need for Deep Cuts or Excessive Fills.**

- 1) The pipeline alignment should be selected such that deep cuts or excessive fills are avoided where possible. Deep cuts not only increase the volume of excavation, but also increase the cost of temporary support for the trench, see Part Three, Section 18 (Temporary Construction Support Criteria). Excessive fill also increases the cost of the project by requiring large volumes of borrow material and extensive compaction efforts. Additionally, future maintenance of the pipeline is more difficult and the loading on the pipe increases substantially which requires the use of a higher class of pipe.

**j. Need for Special Bedding and/or Backfill.**

- 1) Special bedding and backfill invariably increases the cost of the project and its use should be minimized. A pipeline going through an area with poor soil conditions may require special bedding and backfill. Altering the route such that the pipeline does not go through the area with poor soil conditions may eliminate this.





**k. Need for Blocking and/or Restrained Joints.**

- 1) Horizontal bends. At every horizontal bend and other fittings, an unbalanced thrust acts upon the pipeline, which tends to push the pipe joints open. There are two methods for preventing the joints from opening. The first method involves the installation of a concrete block behind the bend, which will transfer the thrust load from the bend to the soil. In the second method, the pipe joints are restrained on both sides of the bend for a sufficient distance. Both methods increase the construction cost as more material and labor is required. To reduce construction costs, if possible, the alignment should be chosen with the least number of bends and other fittings so that the need for thrust restraint is minimized.
- 2) Vertical bends. Similar to horizontal bends, vertical bends also create thrust forces. In the case of upper vertical bends, the thrust force is normally anchored by the weight of a concrete block installed under the bend. Alternatively, the joints may be restrained. For lower vertical bends, the thrust force is either transferred to the soil through a concrete block installed under the bend or by restraining the joints. In both cases, additional costs are incurred. The alignment should be chosen to minimize the need for vertical bends.
- 3) Thrust blocking versus restrained joints.
  - a) Restrained joints are normally used when there is not enough space for the installation of the concrete block due to the existence of other adjacent utilities or other conditions. In such cases, a slight change in the alignment may provide the necessary space for the concrete block and eliminate the need for restrained pipe joints.
  - b) The cost of restraining pipe joints is generally higher than the cost of concrete blocks. Concrete blocks are therefore, the preferred method of thrust restraint. For larger diameter piping, thrust blocks can become large and costly. Therefore, for pipe sizes larger than 24-inch, see Part Three, Section 27 (Thrust Restraint Design for Buried Piping) for further guidance on evaluating the cost of thrust blocking versus restrained joints.

**l. Crossing and working within Marlboro Clay areas.**

- 1) Marlboro Clay is a thin but highly distinctive unit composed of dense, brittle clay, ranging from thickly-bedded to finely laminated, lenticular or hummocky in part, containing partings and thin lenses of micaceous and lignitic laminated silt. The lowest part of the clay contains thin interbeds of glauconitic sand. Marlboro Clay exposures can be found in southern Prince George's County. Marlboro Clay reaches 20 feet in thickness in some places. See Geologic Map of Prince George's County, Maryland by John Glaser, 2003.
- 2) Review available information from Maryland Geological Survey to determine the approximate location of Marlboro Clay.
- 3) Conduct subsurface investigations following Appendix E, Subsurface Investigations for Water and Sewer Design and Construction.



## 20. Geotechnical and Corrosion Submittals.

### a. General.

- 1) This section lists the geotechnical and corrosion submittals that are required to be submitted with the contract drawings. The geotechnical information will not only be for the design, but will also assist the contractor to plan for his construction operation.

### b. First Submittal.

- 1) Plans showing the pipeline alignment and location of the proposed soil borings including proposed depths of each boring, test pit or in-situ tests. Include any pertinent information about the project site soils and ground water conditions that was obtained from previous experience on adjacent sites, geology and soil survey reviews etc.
  - a) Follow the general requirements set forth in Appendix "E", (Subsurface Investigation Requirements for Water and Sewer Design and Construction) for the depth and location of the proposed soil borings.
  - b) Existing soil boring information can be used as part of the required soil borings, if it is in accordance with Appendix "E" and represents the existing ground conditions.
  - c) Soil borings are generally required for special thrust blocking design (for fittings, pipe, valves, etc.) and at structure locations (valves, manholes, etc.).
  - d) Follow the requirements presented in Part Three, Section 26, (Tunnel Design Criteria) and Appendix "F", (Soil Investigation Required for Soft Ground Tunnel Projects) for the depth and number of soil borings required for tunnel/casing crossings.
- 2) Thrust Restraint Schedule, Form "A". This form summarizes the thrust restraint requirements for the contract. Complete and submit the form for each project/design contract; a blank and example Form "A" are included in this section.
- 3) Corrosion Survey Checklist. This form is a preliminary survey to evaluate and determine if corrosion control measures are necessary, see Part Three, Section 28 (Corrosion Control), for the form and submittal requirements.

### c. Second Submittal.

- 1) Soil Data and Geotechnical Report Requirements.
  - a) Pipelines less than 16-inch diameter. Submit the Geotechnical reports in accordance with the requirements of Appendix "E" (Subsurface Investigation Requirements for Water and Sewer Design and Construction).
  - b) Pipelines 16-inch and larger diameter or when the site conditions show metastable, very loose, loose, very soft or soft soils; Petroleum Odor; Fill; Brick; Bituminous Concrete; Wood; Roots; Trace Organics; Oily Smell; Serpentine Rock; Organic Odors; Charcoal Pieces; or high groundwater. Submit a **geotechnical report** in accordance with Appendix "E".



- c) Tunnel crossings. For conditions and submittal requirements for the Tunnel Geotechnical Report, see Part Three, Section 26 (Tunnel Design Criteria).
  - 2) Thrust Restraint Calculations.
    - a) Following the completion of the soil borings, submit the completed Thrust Restraint Schedule, Form "A" and calculations for all special thrust blocking or restrained joint pipe according to the requirements and design examples in Part Three, Section 27 (Thrust Restraint Design for Buried Piping).
    - b) **If entire length is fully restraint with restrained joints, no calculations will be required.**
  - 3) Corrosion Documentation, Form "B". This form is a follow-up to the Corrosion Survey Checklist, it summarizes the results of the field soil and groundwater testing, stray current testing, and identifies the method of corrosion control, see Part Three, Section 28 (Corrosion Control), for this form and requirements.
- d. Electronic data submittals.**
- 1) **Submit all Geotechnical reports (draft/interim/final) in pdf format. The reports should be signed and sealed by the Geotechnical engineer of record for the project.**
  - 2) **All final borings should be submitted in gINT and pdf formats. Enter Atterberg limit, natural moisture content and other soil laboratory test results in the appropriate field of the "Sample" table in the final gINT logs. Soil corrosivity test results should be entered in the final gINT file in the appropriate fields in "WSSC Soil Corrosion Tests & evaluation" table. Use the latest versions of gINT library, data templates and files available on WSSC's website. Refer to Subsections (i) and (j) in Appendix E for "General guidelines and Checklist for Subsurface Investigations" and example reports.**
  - 3) **Refer to Appendix E and F for additional requirements.**





**SAMPLE FORM "A"**

SHEET  1  OF  1

**THRUST RESTRAINT SCHEDULE**

PROJECT NAME  Kings Village  CONTRACT NO.  95AW/AS0000A  DATE  00/00/95

Location		Fitting		Soil Parameters			Restraint System Type			Block Design	
Station	Street Name	Pipe Dia.	Type	$\gamma$ (lbs/ft <sup>3</sup> )	$\phi$ (deg)	Depth ▼	Thrust Block (√)	Restrained Joints (Indicate Type and WSSC Standard Detail)	Combined System Block/Restrained (√)	Special (√)	WSSC Standard Detail
0+00	Crown Gate Road	8"	8"x 8" T	120	30	Dry	√				B/1.3
2+16	" "	8"	1/16 HB	120	30	Dry	√				B/1.0 & B/1.0a
7+56	" "	8"	1/16 HB	120	32	2'	√				Modified B/1.0 & B/1.0a
7+89	" "	8"	1/16 HB	120	32	Dry	√				B/3.2
8+36	" "	8"	8"x 4" R	120	32	Dry		Megalugs			
1+51	Stone Gate Court	6"	10"x 6" T	120	32	Dry		Megalugs	√		B/3.1
2+74	" "	24"	1/8 HB	120	32	Dry				√	
0+00	Kings Terrace	12"	1/16 LVB	120	30	Dry	√				B/1.8
0+92	" "	6"	Cap	120	32	Dry	√				B/1.4
2+87	" "	12"	1/8 HB w/12" 3/4" 17" vert. defl. (up)	120	32	Dry		Megalugs	√		B/3.3
2+98	" "	12"	1/8 HB w/12" 3/4" 17" vert. defl. (dn)	120	32	Dry		Megalugs	√		B/3.3
3+50	" "	12"	1/16 UVB	120	32	3'	√			√	Modified B/1.7



## 21. Lateral Support for Buried Pipelines.

### a. General.

- 1) This section discusses the importance of lateral support for buried flexible pipelines. The topics include when it should be considered and how to determine in the field when special design is required to compensate for low  $E'$ , modulus of soil reaction.

### b. Guidelines.

- 1) Type of pipes. Lateral support plays a significant role in the design of flexible pipes, such as Steel and PVC. Semi-flexible pipes, such as ductile iron, also rely on the lateral support to some extent. The behavior of rigid pipes such as clay or concrete is independent of lateral support.
- 2) Lateral support. Flexible and semi-flexible pipes rely on the lateral support to resist external loading. If adequate side support is not available the pipe may undergo excessive deflection, which may lead to total collapse. The side support is a function of the backfill material placed at the sides of the pipe, its degree of compaction, and also the type and stiffness of in-situ soil.
- 3) Modulus of soil reaction,  $E'$ .
  - a) The contribution of lateral support to external load carrying capacity of pipelines is estimated by the modulus of soil reaction,  $E'$ . The soil modulus characterizes the stiffness of the soil at the sides of the flexible pipeline. The  $E'$  value of the backfill material is related to its type and degree of compaction. The Ductile Iron Pipe Research Association (DIPRA) handbook provides recommended values of  $E'$  for different types of soils. Howard, A.K., "Modulus of Soil Reaction ( $E'$ ) Values for Buried Flexible Pipe" Engineering and Research Center, Bureau of Reclamation, Denver, CO., 1976, provides a comprehensive review of  $E'$  values. Hartley, A.M., Duncan, J.M., "E' and Its Variation With Depth", ASCE Journal of Transportation Engineering, Vol. 113, No. 5, September 1987, provides depth-dependent  $E'$  values for design of flexible pipes.
  - b) In general,  $E'$  of the in-situ material should be estimated in the field by conducting standard penetration tests, cone penetrometer or dilatometer tests. Based on the results of these tests, the type and degree of compaction of in-situ soil is estimated and the literature cited above can be referenced to estimate the  $E'$  value of the in-situ soil.
  - c) Use the smaller of the two  $E'$  values in the design. Alternatively, a finite element analysis may be completed using the corresponding  $E'$  values for in-situ and backfill soil.
- 4) Compensation for low  $E'$ . If the in-situ soil is very soft, having a standard penetration test blow count of four (4) or less, it will have a low  $E'$  value. There are two methods to compensate for the low  $E'$  value.
  - a) Higher-class (thicker) pipe may be used to reduce the required lateral support.
  - b) High quality and well-compacted backfill material may be used all around. The width of the backfill material at the sides of the pipe may be increased to reduce the amount of pressure transmitted to the in-situ soil. This method can only be analyzed by a finite element analysis.



## 22. Slope Stability.

### a. General.

- 1) This section provides information on how to recognize slope instability, the importance of avoiding unstable slopes when selecting pipeline alignments, **minimum requirements and considerations for slope design** and general methods of slope stabilization. Both natural and man-made slopes are susceptible to slope failure, which is associated with downward movement and spreading of the soil mass.
- 2) If an unstable slope is suspected and may be encountered during construction, prepare a **Geotechnical Report** in accordance with the requirements in Part Three, Section 20 (Geotechnical and Corrosion Submittals) **and provisions in this section.**

### b. Slope Failures.

- 1) Causes. Installation of a pipeline in an area where slow but sustained ground movement is occurring due to creep phenomenon will eventually lead to pipe failure. Trench excavation for pipeline installation at the toe of a slope may lead to its failure. An ancient landslide may become reactivated by the vibration resulting from construction machinery used for trench excavation and pipeline installation. Slope failures are normally caused by excavation or undercutting the foot of an existing slope, by an increase in the pore water pressure, by seismic activity such as earthquakes, blasting or pile driving and by the long-term degradation and/or creep of the soil material.
- 2) Signs of instability. Recognition of areas susceptible to slope failure is of paramount importance in the selection of an alignment for a pipeline. An early sign of a slope failure is the formation of surface tension cracks in the upper part of the slope. Other signs include ridging of the soil surface and bulging at the toe of the slope. Apart from these surface features, surface or underground monitoring may accurately measure soil movement. Inclined meters are frequently used for underground movement monitoring.

### c. Type of Soils.

- 1) The type of soil plays a significant role in the behavior of the slope.
  - a) Clays.
    - (1) Most failures in clay soils are of a rotational type where the failure surface is part of a curved surface. Clay soils behave differently in the short and long term. An excavation in clay may be stable in the short term but can become unstable in the long term. Effective stress parameters should be used for long term stability analysis, while total stress parameters should be used for short-term analysis.
    - (2) Stiff fissured clays pose a serious problem as they contain slickensides and shrinkage cracks. Water infiltrating these cracks reduces the shear strength substantially. If such soils are encountered, a geotechnical engineer should be consulted to evaluate the safety factor of the slope and the effect of the pipeline construction on its stability.



- b) Granular soils. In granular soils, the failure is mostly translational. Ground water is a critical factor for the stability of granular soils as it reduces the effective stress resulting in a reduction of the soil shear strength. The safety factor decreases by almost fifty (50%) percent in the presence of ground water. Many slope failures occurring after heavy rainfall are due to a rise in the groundwater table.
- c) Residual soils. Residual soils that are formed by the in-situ weathering of rock usually have a complex structure as they preserve many of the physical features of the parent rock such as joints, faults and folds. **A careful site characterization should be done to establish design shear strength properties in residual soils.**

**d. Soil cut and fill slope design considerations.**

Geotechnical analyses of soil cut slopes shall be performed to assess slope stability for long-term (drained) and short term (undrained) conditions. Potential circular, wedge or other type failure modes shall be analyzed. Slope stability analyses shall be conducted using limit equilibrium methodologies using a computer program such as SLOPEW, PCSTABL, ReSSA, or StedWIN./GSTABL. Circular, sliding, compound, and non-linear and wedge type failures shall be analyzed for potential occurrence of slip surfaces. The Modified Bishop simplified Janbu, Spencer, Morgenstern or other widely accepted slope stability methods shall be used for rotational and irregular surface failure mechanisms.

Soil parameters based upon valid testing requirements shall be used. At a minimum, three laboratory test results shall be required to confirm the soil parameters. The testing program shall be approved by the Commission. The evaluation of global slope stability (long term and short term) shall accommodate potential seepage forces, water infiltration, surficial water runoff and any weak deposits and seams that are adversely impacted by water flow. The global stability analyses shall account for the use of buttressing, placement of select material, or improvements to the foundation material of the embankment, especially at the toe of slope near ponds, wetlands, streams and other locations of poor materials. For all slope stability analyses, linear Mohr-Coulomb model shall be used for soil strength model unless it is approved by the Commission. The following are minimum requirements for cut and fill slopes;

- 1) Permanent soil fills and cut slopes shall be no steeper than 2H: 1V unless they are engineered.
- 2) The minimum factor of safety for both undrained and drained condition in cut slopes shall be 1.5 including surficial stability.
- 3) A minimum factor of safety of 1.3 shall be provided under static loads for permanent fill slopes for both global stability and surficial stability analysis.
- 4) In the absence of required right-of-way, the cut slope shall be engineered through the use of a toe wall, soil nail wall, or other engineering technique.
- 5) If on site fill materials consists of silts or is unknown at the time of analysis, cohesion (c) shall be equal to zero (0).





- 6) For slopes behind Storm Water Management Ponds, reservoirs etc., in addition to global and surficial stability analyses, provide stability analyses for rapid drawdown condition with a minimum factor of safety of 1.1.
- 7) If the slope is adjacent to pond or water, the toe of the slope shall be protected by riprap or other engineered systems

The analyses, design and construction of soil cut and fill side slopes including for storm water management ponds shall accommodate the effects of deterioration and loss of soil resistance due to local climatic and construction conditions. Refer to Appendix E for minimum investigation requirements. All slopes shall be designed to minimize erosion by rainfall and runoff. Adequate drainage and erosion control provisions shall be incorporated in the final design and construction of fill and cut slopes.

**e. Selection of Pipeline Alignment.**

- 1) Any area with a potential for slope failure should be avoided as much as possible by selecting alternative pipeline alignments. If alternative alignments are not available or are prohibitively expensive, consideration should be given to stabilizing the slopes. A thorough site investigation and slope stability analysis should be performed and the slope factor of safety determined before, during, and after the installation of the pipeline.

**f. Method of Stabilization.**

- 1) Numerous methods of slope stabilization may be utilized and basically fall into the following groups:
  - a) Reduce the amount of mass which may drive the slope to failure. Reducing the slope angle is a case in point.
  - b) Increase the soil strength. This may be achieved by different ground modification techniques such as grouting or soil nailing.
  - c) Control the ground and surface water by providing positive drainage, diverting the water flow from the slope area and using temporary and permanent slope erosion control features such as soil stabilization matting, vegetation, etc.
  - d) Use of engineered systems such as retaining walls or reinforced slopes

**g. References.**

- 1) Hsai-Yang Fang, Foundation Engineering, 2nd edition, 1991, Van Nostrand Reinhold.
- 2) Hunt R.E., Geotechnical Engineering Investigation, 1st edition, 1984, McGraw Hill.
- 3) US Army Corps of Engineers, Slope Stability, EM 1110-2-1902, 2003



## 23. Pipeline Design in Wetlands.

### a. General.

- 1) It is the WSSC's policy to avoid and protect environmentally sensitive areas such as nontidal wetlands whenever possible. Since it is not always practical to avoid wetland areas, the WSSC has developed the guidelines below in conjunction with the Maryland Department of the Environment (MDE) Nontidal Wetlands and Waterways Division for pipeline design and construction in wetlands.

### b. Guidelines.

- 1) Every effort should be made to avoid crossing wetlands when selecting the pipeline alignment, see Part Three, Section 19 (Geotechnical Considerations for Pipeline Alignments). When this is impossible, the crossing distance should be kept to a minimum. Indicate on the drawings, the limits of the nontidal wetland, nontidal wetland buffers (twenty five (25) feet, and one hundred (100) feet when slopes are greater than fifteen (15%) percent), and one hundred (100) year flood plain. Consider the following three (3) main objectives when designing a pipeline in wetlands.
  - a) Objective 1. Minimize the area of disturbance in wetlands during construction and backfill as much as possible with the native material that has been excavated.
  - b) Objective 2. Provide proper bedding and side support materials for the pipe; see Part Three, Section 21 (Lateral Support for Buried Pipelines).
  - c) Objective 3. Minimize seepage of ground water along the pipeline, which may drain the wetlands, by the proper selection of trench backfill and pipe bedding.
- 2) To achieve objective 1, WSSC and MDE have prepared the Standard Wetland Notes included in this section for projects which will require excavation of nontidal wetlands. Provide these notes on the drawings for all pipeline construction in nontidal wetlands and buffers where applicable. WSSC may request or provide additional notes, depending on the site conditions.
- 3) To achieve objectives 2 and 3, address these objectives on a case by case basis during the design. WSSC is designated to review this aspect of the design at the same time as the Sediment Control review for each project. WSSC will assist in determining whether special trench backfill and pipe bedding will be required for each project to prevent seepage along the pipeline. If special trench backfill and pipe bedding are required, prepare Special Provisions to the Specifications in accordance with Part Three, Section 6 (Modifications to Specifications and Standard Details).

### c. Standard Wetlands Notes.

- 1) To achieve objective 1, include the following standard wetland notes on the drawings.



**Best Management Practices For Work In Nontidal Wetlands.**

1. Place heavy equipment on mats or suitably operate the equipment to prevent damage to the nontidal wetlands.
2. Use previously excavated material as backfill unless it contains waste metal products, unsightly debris, toxic material or any other deleterious substance. Use clean borrow material when excavated material is not suitable for use as backfill.
3. All excess fill, spoil material, debris, and construction material shall be disposed of outside the nontidal wetland, twenty (25) foot buffer area, and the one hundred (100) year floodplain, and in a location and manner which does not adversely impact surface or subsurface water flow into or out of the nontidal wetlands.
4. Temporary construction trailers or structures, staging areas, and stockpiles shall not be located within the nontidal wetlands, buffer areas or the one hundred (100) year floodplain unless specifically approved by the Maryland Department of the Environment, Nontidal Wetlands and Waterways Division.
5. All stabilization of disturbed areas within nontidal wetlands and buffer areas shall be with the following species: annual ryegrass (*loium multiflorum*), millet (*setaria italica*), barley (*hordeum sp.*), oats (*uniola sp.*) and/or rye (*secale cereale*). These species will allow for the stabilization of the disturbed area while also allowing for the voluntary revegetation of natural wetland species. Other non-persistent vegetation may be acceptable, but must be approved by the Maryland Department of the Environment, Nontidal Wetlands and Waterways Division, prior to use. Kentucky 31 fescue shall not be utilized in the wetland or buffer areas. Seed and mulch disturbed areas to reduce erosion after construction activities have been completed.
6. Rectify any temporarily impacted areas by restoring to existing grades and elevations, and by performing appropriate vegetative stabilization. Wetlands and adjoining buffer areas shall not be mowed or otherwise managed to prevent the re-establishment of woody vegetation.
7. To protect important aquatic species, in-stream work is prohibited by the classification of the stream. Adhere to time-of-year restrictions as required by the Maryland Department of the Environment under COMAR 26.08.02.



## 24. Pipelines Crossing Contaminated Areas

This section provides the minimum standard criteria for the design and construction of water and sewer pipelines in contaminated areas. This section is intended to be a guideline. As new regulations, industry standards, and innovative technologies (remedial actions and pipeline construction) evolve, it is the responsibility of the designer to evaluate the technologies available and utilize the best available technology for pipeline construction in contaminated areas, such that the following four minimum standard criteria will be met to the WSSC's satisfaction:

- a) No unreasonable risk to WSSC customers.
- b) No more than minimal risk to WSSC workers (risk that could be managed with Level D personal protective equipment).
- c) No more than minimal increase in operational and maintenance costs.
- d) No unreasonable liability risks for the WSSC.

This section is arranged to provide the designer with general and background information about encountering contamination (Section 24.a.2), the types of contaminants (Section 24.b.1), and how to determine the distribution of contaminants (Section 24.b.2) including consideration of future migration (Section 24.b.3) and risks (Section 24.b.4). Trench excavation in contaminated areas is outlined in Section 24.c, pipeline materials for contaminated areas are outlined in Section 24.d, and trench backfill considerations in Section 24.e.

### a. General.

#### 1) Definitions

- a) Action Level - used by Occupational Safety & Health Administration (OSHA) and National Institute for Occupational Safety and Health (NIOSH) to express a health or physical hazard. Indicates the level of a harmful or toxic substance/activity which requires medical surveillance, increased industrial hygiene monitoring, or biological monitoring. Action levels are generally set at one half of the permissible exposure limit (PEL), but the actual level may vary from standard to standard. The intent is to identify a level at which the vast majority of randomly sampled exposures will be below the PEL.
- b) Environmental Professional - registered Professional Engineer (geotechnical, environmental), geologist, engineering geologist, hydrogeologist, or environmental scientist certified by respective professional associations, or qualified by combination of education and experience to prepare subsurface investigation plans and direct their execution.
- c) Groundwater Standard - either the Maximum Contaminant Level (MCL) value for a chemical, the Secondary Drinking Water Regulation value for a chemical, or the highest value from the criteria identified in the Maryland Department of the Environment Generic Numeric Cleanup Standards for Groundwater.



- d) Hazardous Substance - any substance defined as a hazardous substance under the Comprehensive Environmental Response, Compensation and Liability Act (CERCLA) of 1980, as amended by the Superfund Amendments and Reauthorization Act of 1986 or in any update or amendment; or identified as a controlled hazardous substance by the Department in the Code of Maryland Regulations.
- e) Lower explosive limit (LEL) - the lowest concentration of gas or vapor that burns or explodes, at ambient temperatures, if an ignition source is present.
- f) NAPL - Non Aqueous Phase Liquid (NAPL) in surface water, groundwater, the vadose zone, or the ground surface. NAPLs commonly encountered include LNAPLs, or light NAPLs which are commonly associated with petroleum-related products and have a density less than water, or DNAPLs, dense NAPLs, which are commonly associated with chlorinated solvents and have a density greater than water. Soluble NAPLs may partition to aqueous phase; volatile NAPLs may partition to gas phase.
- g) Permissible Exposure Limit (PEL) – the maximum concentration of a chemical that a worker may be exposed to under OSHA regulations. PELs can be defined as ceiling values (or concentrations that should not be exceeded at any time), or 8-hour Time Weighted Averages that are average values of exposure over the course of an 8 hour work shift.
- h) Soil Screening Criteria – Screening criteria (concentration for an individual chemical) above which additional assessment/evaluation of potential risk to human health or the environmental and/or design specification to address impacted soil **is** required. The soil screening criteria may be developed by the designer based on site specific land use. In lieu of developing site specific criteria, the designer may base the screening criteria on one of the following:

EPA Region III Risk Based Concentration, State of Maryland Cleanup Standard for Non-residential Soil, or State of Maryland Anticipated Typical Concentrations (published background concentrations).

## 2) Encountering Contamination

To the extent practical, align the pipeline to avoid contaminated areas. See the Flowchart for Evaluating and Encountering Contamination in Pipeline Areas on page C-24.11 thru C-24.14 in this section. Where avoidance of contaminated areas is not practical, design and construction of the pipeline is to be planned such that nature and extent of contamination are delineated along the pipeline alignment. Following delineation, design and construction must be planned such that one of the following conditions is met:

- a) All contamination is removed from the alignment area and the areas immediately adjacent and/or up-gradient of the alignment to background conditions;
- b) Contamination is removed from the alignment area and the areas immediately adjacent and/or up-gradient of the alignment based on state, federal, or site-specific screening criteria applicable for the alignment area; or,



- c) The design and construction of the pipeline alignment incorporates engineering controls and response measures to mitigate contaminant migration pathways and exposures to the pipeline. Design and construction should also include the following
- (1) Delineation of the nature and extent of contamination along the pipeline alignment and the areas directly up-gradient of the alignment.
  - (2) Health and safety plan to address or eliminate potential worker exposures during pipeline construction and maintenance.
  - (3) Management plan for impacted media removed during pipeline construction and maintenance.
  - (4) Pipeline materials which are compatible with the contaminant(s) identified in soil, groundwater and/or soil gas.
  - (5) Design considerations to ensure no environmental degradation occurs along the pipeline trench or inside the pipeline due to the transport of contaminants. **Examples** of Environmental Considerations for Pipeline Design through Impacted Media are shown on page C-24.15 in this section. The designer must consider appropriate screening criteria for soil, groundwater and air; environmental monitoring recommendations specific to the contaminant(s) encountered; compatibility of system materials specific to the contaminant(s) encountered; and waste management options for contaminated soil and groundwater in completing investigation, design and construction of a pipeline through a contaminated area. Long term operation and maintenance requirements such as venting of gases, groundwater treatment, and health and safety plans for WSSC personnel should also be addressed.
- 3) Cross Reference to Related Information and WSSC Documents

For the WSSC minimum requirements for evaluating potential impacts along possible WSSC pipeline alignments, refer to the contamination screening procedures established in the WSSC Development Services Process Manual and the Design Checklist in Appendix A of this manual.

For geotechnical considerations for the design of pipelines through contaminated areas, see also Part Three, Section 19, (Geotechnical Considerations for Pipeline Alignments).



**b. Contaminant Type and Distribution.**

Water and sewer system materials (e.g. pipe material, linings, gaskets) can react with contaminants in the gas, liquid or solid phases in the surrounding external environment. Installation and repair of system components provide additional opportunity for contaminants in the subsurface environment to pose worker exposure as well as intrusion hazards into the pipeline. Commonly encountered contaminants include volatile organic compounds (petroleum – based and chlorinated solvents), explosive gases, asbestos, metals, and refuse.

## 1) Commonly Encountered Contaminants

## a) Petroleum Products (LNAPL and partitioned)

Associated sources of petroleum products include gasoline filling stations, automotive repair facilities, bulk oil storage terminals, and underground storage tanks. Common chemicals of concern include benzene, toluene, ethylbenzene, xylenes (BTEX), methyl tert-butyl ether (MTBE), naphthalene, and semi-volatile organic compounds (SVOCs).

## b) Chlorinated Solvents (DNAPL and partitioned)

Associated sources include dry cleaners, machining operations and automotive refinishing and repair operations. Common chemicals of concern include the VOCs tetrachloroethene (PCE or PERC), trichloroethene (TCE), trichloroethane (TCA), dichloroethene (DCE) isomers, vinyl chloride, carbon tetrachloride, and chlorobenzene.

## c) Landfill Operations (e.g. explosive and toxic gases such as methane, hydrogen sulfide)

Associated concerns at landfills include explosive and toxic gases. Any VOC that is present at concentrations in excess of its LEL presents an explosive hazard. One common explosive gas, methane, is a colorless, odorless gas which presents a health and safety hazard and explosion hazard. Its vapor density is 0.554 and is, therefore, lighter than air. Slightly soluble in water.

## d) Asbestos

Associated sources include piping material (asbestos cement pipe material) **and certain types of** surrounding geologic **formations**. Airborne asbestos fibers present a significant worker inhalation exposure hazard during the installation and repair of pipelines.

## e) Metals

Associated sources include landfills and industrial facilities. Common metals identified include lead, arsenic, chromium, and mercury. May be less mobile in the subsurface if adsorbed on soil matrix, but some soluble ionic fraction can travel in groundwater.

## 2) Depth and Horizontal Extent of Impacted Ground Relative to Depth and Length of Pipeline

Where potential contamination has been confirmed, an investigation must be performed to determine the nature and extent of the contamination within the pipeline alignment area. Prior to start of construction activities, an environmental sampling plan, prepared by an Environmental Professional should be submitted to WSSC for review. Depending upon the site characteristics, regulatory oversight may be required. Where applicable, the Environmental Professional is responsible for coordinating investigatory activities as



promulgated. Timelines for submittals of environmental sampling plans, investigation results, and related documents should be established by the designer at the onset of the project and should be sufficient to allow the WSSC appropriate time for review and comment.

Examples of investigation considerations which may be appropriate for each of the above contaminants are presented on the environmental consideration matrix included in Flowchart for Evaluating and Encountering Contamination.

3) Future Contaminant Migration from Impacted Areas Adjoining New Pipeline

Potential future contaminant exposure and migration of the contaminant(s) should be considered as part of the pipeline design. Where appropriate, this evaluation may include fate and transport assumptions, evaluation of potential exposure pathways, and evaluation of the potential for permeation and leaching and transport along the pipeline alignment.

4) Risk Considerations

Risk to human health and the environment should be considered for alignments crossing or located in the vicinity of contaminated areas. The scope of the risk assessment may be qualitative or quantitative in nature. However, the designer must provide sufficient information to WSSC to evaluate the need for engineering controls and response measures to mitigate contaminant migration pathways and exposures along the pipeline alignment and to meet the four minimum standard criteria for the design and construction of water and sewer pipelines in contaminated areas as stated in the introduction to this section.

a) Acute vs. Chronic Exposure Conditions

Include within the risk assessment a summary of acute and chronic effects associated with the site contamination. Acute toxicity is considered to be any poisonous effect produced within a short period of time following exposure and resulting in biological harm and often death; chronic exposure is considered to be of a persistent, recurring, or long-term nature.

b) Comparison to Soil Screening Criteria

For each contaminant identified at the site, the maximum concentration should be compared to established state and/or federal screening criteria (human health and the environment), federal worker exposure criteria (OSHA action limits, permissible exposure limits) as an initial screening to determine engineering controls and/or response measures to be incorporated into the design and construction of the pipeline alignment.





### c. Trench Excavation Considerations.

Where the contamination is left in place in the pipeline alignment area, or removed only to the extent required by state, federal, or site-specific screening criteria applicable for the alignment area, design and construction should incorporate engineering controls and response measures to mitigate contaminant migration pathways and exposures.

#### 1) Soil Screening Criteria

Design and construction should include a plan for environmental oversight by an Environmental Professional and screening of soil excavated during construction of the pipeline. This plan should provide guidance for the screening, management, storage and disposal of contaminated soil removed during excavation activities. The plan should also specify screening equipment and action levels (for reuse, segregation, and disposal) specific to the contaminant identified within the pipeline alignment area. Specific soil screening equipment and action levels will be based on the contaminants and concentrations identified in the pipeline alignment area.

#### 2) Dewatering

Design and construction should include a plan for testing, storage (if required), treatment (if required), and disposal of groundwater removed during dewatering. Dewatering must be performed in accordance with state and federal regulations and must meet any site specific discharge criteria (e.g., permits).

#### 3) Worker Health and Safety

As is the case with all WSSC construction, it is the responsibility of the contractor to provide proper health and safety measures for his workers and comply with federal, state, and local laws, ordinances, and regulations pertaining to safety and handling of the contaminated soil and/or groundwater. The designer must submit all necessary information, including Health and Safety precautions, in order that the WSSC can inform the contractor of all potential hazards

#### 4) Waste Management

Design must include a management plan for impacted media removed during pipeline construction and maintenance. Implementation of the plan will be the Contractor's responsibility, and the WSSC reserves the right to inspect for plan compliance during construction at any time. Required plan elements include:

- a) All waste material generated during construction, including excavated soil and groundwater, as applicable, must be characterized for appropriate disposal and/or reuse options. Disposal must be performed in accordance with state and federal regulations.
- b) Excavated material that is considered contaminated shall be **shown as** segregated and each shall be stockpiled separately. Excavated material shall be placed on and covered with polyethylene sheeting and surrounded by a temporary fence with warning signs that read as follows: KEEP OUT. CONTAMINATED SOIL AND REFUSE MATERIAL.



- c) Excavated material considered contaminated shall be transported off-site by a permitted waste carrier to an authorized contaminated waste disposal facility. The contractor shall arrange for transport and disposal of the segregated contaminated material, and shall be responsible for securing appropriate documentation certifying the proper transport and disposal of contaminated materials. The contractor shall submit this certification as soon as practicable, and not later than 30 days after completion of work in the area of contamination.

**d. Pipeline Material Considerations.**

Materials selected for pipeline construction, including pipe materials, coatings, trench linings, gaskets and appurtenances, must be compatible with identified site contaminants such that permeation, leaching, or transport along the pipeline alignment area is limited to the greatest extent possible.

Examples of compatible material options, specific to the common contaminants presented in this section, are provided in the Environmental Consideration Matrix For Pipeline Design Through Impacted Media; however, as industry standards and innovative construction technologies or materials emerge, it is the responsibility of the designer to evaluate the technologies available and utilize the best available technology for pipeline construction. Design guidelines and considerations for selection of appropriate pipeline materials are presented in this section.

1) Pipe Resistance to Permeation and Degradation by Liquids and Gases

a) Pipe Materials

- (1) In general, PVC is not suitable for water supply lines and sewer lines in areas contaminated with gasoline, **petroleum products** and solvents.
- (2) Extreme caution shall be used if HDPE pipe is to be used at a contaminated area as it has a limited resistance to **gasoline** and solvents. The pipe manufacturer's maximum pressure rating should be reduced by 25% as a safety factor when the long term strength of the pipe is considered to be affected. It is not recommend using HDPE **in areas of contamination**.
- (3) **Reinforce concrete pipe (RCP)** is not suitable for areas contaminated with **gasoline** and solvents, as they can permeate the concrete.
- (4) Ductile Iron **Pipe (DIP)** and steel pipes are not attacked by and are impermeable to hydrocarbon compounds. However, they can be corroded by acids and electrochemical reactions if unprotected.

b) Coatings

- (1) For **DIP exterior coatings, see Part One, Section 2 (Pipe Materials and Fittings)**.
- (2) The selection of coating for chemical resistance must be coordinated with other corrosion control considerations. See part three, Section 28 (Corrosion Control).



c) Trench Lining

Flowable fill is recommended for use in contaminated areas. Flowable fill, as described in Standard Specification Section 03300 (Cast-In-Place Concrete), shall be made of cement, fly ash, and water. The pipe should be encased in flowable fill to one foot above the crown of the pipe.

2) Gaskets

- a) The most common type of gasket used for Reinforced Concrete Pipe (RCP) is manufactured from natural rubber (NR). The chemical compound of the gasket is polyisoprene. Gaskets for all WSSC concrete sewer pipes shall meet the requirements of ASTM C443.
- b) The common type of gasket used for DIP and PVC is made of a synthetic rubber, which is a copolymer of styrene and butadiene (SBR). It is generally suitable for applications in fresh water, and sanitary sewage environments. All gaskets for DIP shall meet the minimum requirements of AWWA C111/A21.11. Gaskets for all WSSC PVC sewer pipes shall meet the requirements of ASTM F477.
- c) Nitrile (NBR) or Buna-N gasket is another type of gasket made of synthetic rubber, which is a copolymer of butadiene and acrylonitrile. In general, this type of synthetic rubber has good resistance to refined petroleum products like gasoline, kerosene, jet fuel and lubricating oils. It may not be effective for use with aromatic hydrocarbons like benzene and toluene or chlorinated hydrocarbons like chloromethane and chlorobenzene.
- d) Viton, Fluorel, or FKM gasket is made up of fluoroelastomer or fluorocarbon rubber. It is a very special and expensive synthetic terpolymer that contains various proportions of fluorine, ethylene, and propylene. This material offers chemical resistance to about 95% of all industrial chemicals including aromatics and chlorinated solvents. It currently represents the best available technology for gaskets used in a hostile chemical environment.
- e) If the gasket will be used for the pipes in a contaminated area, then the additional test as specified by ASTM D471 shall also be conducted to determine the effect of the liquids.

3) Material Compatibility and Junction with Contiguous Pipeline in Non-Contaminated Areas

At a junction with a contiguous pipeline, piping materials and junctions from the non-contaminated areas must be compatible with the contaminated areas. Further, the junction must be designed to limit transport along the pipeline alignment area. Typical methods used to limit transport include pipe bedding materials such as non-permeable plugs and flowable fill (24.e.1).

**e. Trench Backfill Considerations.**

- 1) Pipe Bedding Materials (low relative permeability, ability to not act as preferential conduit for contaminant migration)
  - a) Bentonite for backfill, where required, shall be 100 percent high swelling granular sodium bentonite, with a maximum moisture content of 12 percent.



- b) Flowable fill, as described above, is a WSSC recommended backfill option.
  - c) Specify any necessary provisions for future maintenance of the pipelines with special backfill material.
- 2) Limiting Contaminant Migration to Private Property via the Pipeline

Transport along utility lines is a known hazard to homeowners. Therefore, transport along utility lines must be eliminated. Two known methods to limit migration along the utility lines are non-permeable plugs and flowable fill, which is much less permeable than gravel. Flowable fill has already been successfully utilized by WSSC.

3) Trench Isolation

Trench isolation is recommended in pipeline alignment areas intercepting contamination. In addition to low permeable pipe bedding materials, liners (e.g. HDPE), stainless steel or ductile iron sleeves or equivalent barrier should be considered to isolate the trench from the surrounding impact(s). For example, pipe can be installed within a steel casing to prevent permeation of low-molecular weight hydrocarbons into the pipeline through its rubber joint gaskets.

4) Surface Capping

Containment technologies, such as surface capping, may be appropriate to control the migration of a contaminant to sensitive receptors without reducing or removing the contaminant. Capping also reduces the infiltration and percolation of precipitation, and limits leaching of shallow contaminants to deeper pipelines or to groundwater.

- a) Hard-surface capping works by maintaining a high-strength, low-permeability cover over the waste to stabilize surface soil and reduce infiltration of surface water. The low-permeability layer can be made from either asphalt or concrete.
- b) In situ capping involves using containment of contaminated soil with a stable cover formed using layers of soil, sediment, gravel, rock, and/or synthetic materials. The cap reduces contaminant mobility and access to the contaminants.
- c) Capping system designs should consider the effect of any possible subsurface diversion or redirection of soil gas that may have been emitted at the ground surface prior to capping.

5) Gas Venting Systems

Venting systems may be appropriate and should be considered where VOC or explosive gas (e.g., methane) contamination has been identified. Further, where explosive gas contamination has been identified in association with landfills, the long term settlement of the pipeline shall be considered and appropriate design measures should be incorporated.

- a) Where the concentration of a VOC (e.g., methane or explosive gas) is identified at concentrations greater than 25% of its lower explosive limit, consideration of a gas venting system may be required to reduce VOC concentrations to the allowable levels



- b) For VOC impacts, bioventing or soil vapor extraction may be appropriate as they are in situ remediation technologies that use indigenous microorganisms or volatilization to decrease concentrations of organic constituents adsorbed to soils in the unsaturated zone. Soils in the capillary fringe and the saturated zone are not affected. In bioventing, the activity of the indigenous bacteria is enhanced by inducing air (or oxygen) flow into the unsaturated zone (using extraction or injection wells) and, if necessary, by adding nutrients. It should be noted that implementation of a bioventing or soil vapor extraction system in the pipeline alignment area may delay pipeline installation or maintenance activities.

#### 6) Liquid Monitoring Systems

Where LNAPL, DNAPL, or concentrations of a contaminant are identified in groundwater intercepting the pipeline alignment area, a groundwater monitoring program, consisting of regular monitoring of groundwater quality and groundwater flow should be implemented as part of the design and construction of the pipeline to evaluate the continuing effectiveness of the pipeline design and ensure WSSC customer and worker safety.

#### **f. Regulatory Considerations.**

- 1) **Coordination with EPA, MDE or County Environmental Agencies**  
Design and construction activities must comply with all applicable local, state and federal regulations. It is the responsibility of the designer to ensure the coordination with the appropriate agencies, obtain appropriate permits (e.g., NPDES, waste permits, utility clearances, etc.) and documentation (e.g., laboratory analytical reports), and conditions requiring oversight or specific training associated with the design and construction of the pipeline alignment.



**FLOWCHART FOR EVALUATING AND ENCOUNTERING CONTAMINATION**

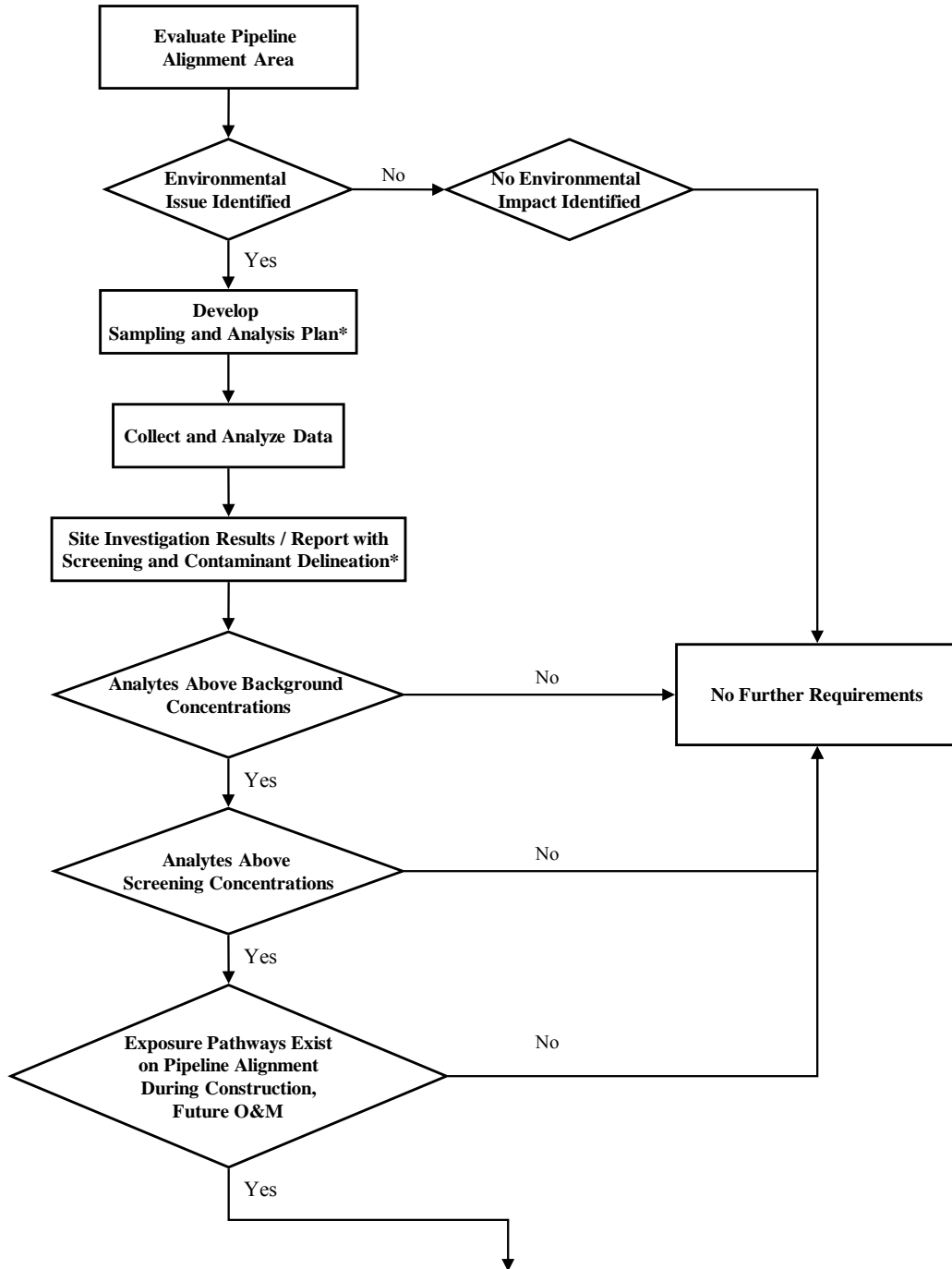

**FLOWCHART FOR EVALUATING AND ENCOUNTERING CONTAMINATION**  
**(continued)**

(From Previous Page)



\*WSSC review required before proceeding to next step.



**FLOWCHART KEY**

Flowchart for Evaluating and Encountering Contamination

<b>EVALUATE ALIGNMENT AREA</b>	The designer / applicant should evaluate the proposed alignment area for potential contamination in and surrounding the proposed alignment. At a minimum, completion of the WSSC Environmental Questionnaire and a site visit should be performed.
<b>ENVIRONMENTAL ISSUE IDENTIFIED</b>	<p>If preliminary findings indicate a potential environmental condition, additional investigation should be performed to confirm or deny the presence of each potential environmental condition. Additional investigation could include:</p> <ul style="list-style-type: none"> <li>• Regulatory records review</li> <li>• Historic records review</li> <li>• Interviews with persons knowledgeable with the site</li> <li>• Phase I Environmental Site Assessment</li> <li>• Review of prior environmental investigations/remediation</li> </ul> <p>The results of the evaluation must be signed by an Environmental Professional and submitted to WSSC for review.</p>
<b>DEVELOP SAMPLING AND ANALYSIS PLAN</b>	If an environmental condition has been confirmed or is suspected to exist, an investigation should be performed to determine the nature and extent of the contamination within the pipeline alignment area. Prior to start of construction activities, an environmental sampling plan, prepared by an Environmental Professional should be submitted to WSSC for review.
<b>COLLECT AND ANALYZE DATA</b>	<p>Results of the environmental sampling should be compiled and interpreted.</p> <p>For each chemical identified in soil or groundwater within the pipeline alignment area, an exposure point concentration should be determined and compared to the selected screening criteria. Screening criteria may be background, or state or federally published standards (e.g. USEPA MCLs, USEPA RBCs, MDE Cleanup Standards).</p>
<b>BACKGROUND CONCENTRATIONS SCREENING</b>	<p>Background concentrations may be determined based on site-specific data or published background concentrations, such as the Maryland Anticipated Typical Concentrations (ATCs).</p> <p>If chemical(s) are identified below “background” concentrations, submit the results of the limited investigation for review by WSSC.</p>
<b>ANALYTES ABOVE SCREENING CRITERIA</b>	<p>A combination of background, state, and federally published standards, or site specific standards may be used for pipeline alignment area. If chemical(s) are identified above the selected criteria, the designer / applicant should perform an evaluation of potential exposure pathways.</p> <p>If chemical(s) are identified below screening criteria concentrations, submit the results of the limited investigation for review by WSSC.</p>





**FLOWCHART KEY (continued)**

Flowchart for Evaluating and Encountering Contamination

<p style="text-align: center;"><b>EVALUATE POTENTIAL EXPOSURE PATHWAYS</b></p>	<p>The designer / applicant should evaluate nature and extent of impact and determine if exposure pathways exist 1.) during construction activities, 2.) within the pipeline alignment area, or will exist 3.) during future operation and maintenance of the pipeline. Submit the results of the evaluation and recommendations for review by WSSC.</p> <p>Example scenarios include the following:</p> <ol style="list-style-type: none"> <li>1.) Non-volatile impacts (metals, asbestos) identified. Impacts are limited to surface soil above the pipeline alignment area and the contamination is not migrating. Exposure pathways during construction and future maintenance activities are complete. Recommend removal of impacted media, development of a plan for the management of impacted media and to address health and safety considerations during construction (e.g. dust monitoring, PPE).</li> <li>2.) Volatile impacts are deep and limited to groundwater. Exposure pathway through soil vapor migration to the pipeline alignment area is complete. Recommend engineering controls, including using compatible pipeline materials to avoid permeation and transport and soil venting to avoid volatile gas buildup.</li> <li>3.) Mixed media impacts identified throughout soil and groundwater intersecting the pipeline alignment area. All exposure pathways are complete. Recommend repositioning pipeline alignment, development of a plan for the management of impacted media and health and safety plan, and engineering controls during construction.</li> </ol>
<p style="text-align: center;"><b>REMOVE IMPACTED MEDIA</b></p>	<p>Where impacted media removal has been recommended, an impacted media management plan identifying the proposed area and volume for excavation, excavation health and safety protocols and confirmatory sampling should be submitted to WSSC for review.</p>
<p style="text-align: center;"><b>REPOSITION PIPELINE ALIGNMENT</b></p>	<p>Submit plans for repositioning of the pipeline alignment area for review to WSSC.</p>
<p style="text-align: center;"><b>IMPLEMENT HEALTH AND SAFETY / ENGINEERING CONTROLS</b></p>	<p>As applicable, submit a health and safety plan, pipeline material recommendations and rationale, plan for the management of impacted media, and operations and maintenance plan to WSSC for review.</p>



**ENVIRONMENTAL CONSIDERATION MATRIX FOR PIPELINE DESIGN THROUGH IMPACTED MEDIA**

Contaminant of Concern	Screening Criteria Reference			Environmental Monitoring Reference	Compatible Materials*			Trench Backfill**	O&M
	Soil	Groundwater	Air		Piping	Gaskets	Trench Lining		
Volatile Organic Compounds	MDE Cleanup Standards USEPA RBCs	MDE Cleanup Standards USEPA MCLs	PEL or TLV/STEL IDLH	NIOSH OSHA	Epoxy-coated Ductile Iron Pipe (hydrocarbons) Steel casing	NBR FKM EPDM (MEK, acetone)	Flowable Fill	Flowable Fill Bentonite	Venting Liquid Monitoring Groundwater Treatment Dewatering Health and Safety Plan
Semi-volatile Organic Compounds	MDE Cleanup Standards USEPA RBCs	MDE Cleanup Standards USEPA MCLs	PEL or TLV/STEL IDLH	NIOSH OSHA	PVC HDPE	Neoprene (heat and oil only) FKM	Overexcavate Geotextile fabric Warning layer	Clean Fill	Health and Safety Plan
Polychlorinated Biphenyls and Pesticides	MDE Cleanup Standards USEPA RBCs	MDE Cleanup Standards USEPA MCLs	PEL or TLV/STEL IDLH	NIOSH OSHA	PVC HDPE	NBR FKM	Overexcavate Geotextile fabric Warning layer	Clean Fill	Health and Safety Plan
Corrosive Soil/Groundwater	MDE Cleanup Standards USEPA RBCs	MDE Cleanup Standards USEPA MCLs	PEL or TLV/STEL IDLH	NIOSH OSHA	PVC HDPE	EPDM (dilute acids) FKM	Overexcavate Geotextile fabric Warning layer	Clean Fill	Health and Safety Plan
Mixed Impacts (Landfills)	MDE Cleanup Standards USEPA RBCs	MDE Cleanup Standards USEPA MCLs	PEL or TLV/STEL IDLH	NIOSH OSHA	Epoxy-coated Ductile Iron Pipe Steel casing	NBR FKM EPDM	Flowable Fill Bentonite	Flowable Fill Bentonite	Venting Liquid Monitoring Groundwater Treatment Dewatering Health and Safety Plan
Metals	MDE Cleanup Standards USEPA RBCs	MDE Cleanup Standards USEPA MCLs	PEL or TLV/STEL IDLH	NIOSH OSHA	PVC HDPE	NBR FKM	Overexcavate Geotextile fabric Warning layer	Clean Fill	Health and Safety Plan
Asbestos	MDE Cleanup Standards USEPA RBCs	MDE Cleanup Standards USEPA MCLs	PEL or TLV/STEL IDLH	NIOSH OSHA	***	***	***	***	Health and Safety Plan



- \* ANSI/AWWA Standards C900 through C950 state that if a water main must pass through an area of gross contamination, the manufacturer should be consulted regarding the permeation of the pipe walls and joint fittings prior to selecting the material. Pipe materials such as polyethylene, polybutylene, PVC, and asbestos cement; and elastomer gaskets (e.g. rubber, viton, etc.), may be subject to permeation by lower molecular weight organic solvents or petroleum products. It is recommended that newly lined pipes be flushed prior to release to service.
- \*\* Warning layer – placed to identify changed in soil conditions. Typically consists of thin, orange plastic webbing or equivalent.
- \*\*\* Asbestos sources are typically associated with existing piping material (asbestos cement pipe material) or the surrounding geologic formation. Hazards presented are primarily associated with worker inhalation exposure hazard from airborne fibers during the installation and repair of pipelines.

#### **Consideration Matrix Notes:**

##### **Screening Criteria/Environmental Monitoring References**

- MDE. 2001. *State of Maryland Department of the Environment Cleanup Standards for Soil and Groundwater Interim Final Guidance, Update No. 1.* August.
- National Institute of Occupational Safety and Health (NIOSH)/Occupational Safety and Health Administration (OSHA)/U.S. Coast Guard (USCG)/U.S. Environmental Protection Agency (USEPA) *Occupational Safety and Health Guidance Manual for Hazardous Waste Site Activities*, October 1985.
- NIOSH. *Pocket Guide to Chemical Hazards (NPG)*. U.S. Department of Health and Human Services, October 2003. DHHS (NIOSH) Publication No. 2004-103.
- NIOSH. *Occupational Safety and Health Guidance Manual for Hazardous Waste Site Activities*, October 1985.
- OSHA. Standards for General Industry, 29 CFR 1910.1000, *Air Contaminants*.
- OSHA. Standards for Construction Industry, 29 CFR 1926, including Hazardous Waste Operations and Emergency Response 29 CFR 1926.65, and Hazard Communication 29 CFR 1926.59.
- OSHA. Standards for General Industry, Hazardous Waste Operations and Emergency Response 29 CFR 1910.120.
- USEPA. Human Health Risk Assessment, Risk-Based Concentration Table. <http://www.epa.gov/reg3hwmd/risk/human/index.htm>.
- USEPA. National Primary Drinking Water Regulations (NPDWRs or primary standards). <http://www.epa.gov/safewater/mcl.html>.

##### **Piping Materials**

- Ductile Iron/Steel – Resistant to hydrocarbons; polyethylene encasement offers corrosion protection from acids and electrochemical reactions, in hydrocarbon impacted soil.
- PVC – Polyvinyl chloride; not suitable for water supply lines and sewer lines in areas contaminated with gasoline and solvents.
- HDPE – Limited resistance to gasoline and solvents. The pipe manufacturer's maximum pressure rating should be reduced by 25% as a safety factor when the long term strength of the pipe is considered to be affected. Recommended not to use HDPE.
- Concrete/Asbestos Cement – Not recommended for areas impacted with gasoline, petroleum products and solvents. Gasoline and solvents can permeate the concrete.

##### **Coatings**

- Liquid Epoxy coating – Recommended for corrosion protection for ductile iron piping and steel piping.

##### **Gasket Materials**

- Gaskets for all WSSC PVC sewer pipes shall meet the requirements of ASTM F477. If the gasket will be used for the pipes in a contaminated area, then the additional test as specified by ASTM D471 shall also be conducted to determine the effect of the contaminants present in the pipeline alignment area.
- EPDM – Ethylene propylene diene monomer; EPDM is a general purpose synthetic rubber with good environmental resistance to dilute acids and bases, and chemical slats.
- Neoprene – Heat and oil resistant synthetic rubber. Resistance to most unrefined petroleum products and aliphatic hydrocarbons, not recommended for solvents, fuels or unsaturated hydrocarbons.
- NBR – Copolymer of butadiene and acrylonitrile, also referred to as nitrile. Synthetic rubber with good resistance to refined petroleum products such as gasoline, kerosene, jet fuel and lubricating oils. Not recommended for aromatic hydrocarbons such as benzene, toluene, or chlorinated hydrocarbons such as chloromethane and chlorobenzene.
- FKM – Synthetic terpolymer, Fluorocarbon. Offers chemical resistance to 95% of all industrial chemicals including aromatics and chlorinated solvents. Excellent environmental and heat resistance.
- NR – Most common gasket for Reinforced Concrete Pipe (RCP) is manufactured from natural rubber (NR). The chemical compound of the gasket is poly- isoprene. Gaskets for all WSSC concrete sewer pipes shall meet the requirements of ASTM C443.
- SBR – Copolymer of styrene and butadiene that is the most common synthetic rubber used in pipe gaskets. SBR is the material upon which the AWWA C111/A21.11 Standard is based.

##### **Trench Lining / Backfill**

- Flowable Fill – Recommended for use in contaminated areas. Flowable fill, as described in Specification Section 3300 (Cast-In-Place Concrete), shall be made of cement, fly ash, and water. The pipe should be encased in flowable fill to one foot above the crown of the pipe.



**Washington Suburban Sanitary Commission  
ENVIRONMENTAL QUESTIONNAIRE**

- |  | NO                       | YES                      |
|--|--------------------------|--------------------------|
| 1. To the best of your knowledge, is the property presently used for industrial and/or commercial purposes including, but not limited to, a landfill, gasoline station, motor repair facility, printing facility, dry cleaners, photo developing laboratory, junkyard, research laboratory, chemical manufacturing, mining, military facility or as a waste treatment, storage, disposal, processing, or recycling facility; or do you have any knowledge that the property was used for the above purposes in the past?                     | <input type="checkbox"/> | <input type="checkbox"/> |
| 2. To the best of your knowledge, is the adjoining property presently used for industrial and/or commercial purposes including, but not limited to, a landfill, gasoline station, motor repair facility, printing facility, dry cleaners, photo developing laboratory, junkyard, research laboratory, chemical manufacturing, mining, military facility or as a waste treatment, storage, disposal, processing, or recycling facility; or do you have any knowledge that the adjoining property was used for the above purposes in the past? | <input type="checkbox"/> | <input type="checkbox"/> |
| 3. To the best of your knowledge, are there currently any dumping, storage, burying, or burning of any hazardous substances, petroleum products, unidentified waste materials, industrial batteries, pesticides, paints, industrial drums, sacks of chemicals, or any other chemicals greater than 5 gallons at this property; or do you have any knowledge that the above activities occurred on the property in the past?  | <input type="checkbox"/> | <input type="checkbox"/> |
| 4. To the best of your knowledge, are there currently any registered or unregistered underground and/or above ground storage tanks, vent pipes, fill pipes, injection and/or dry wells, transformers, capacitors, hydraulic equipment, stained soils, or contaminated wells at this property; or did you observe evidence or do you have any knowledge that the above were used/observed on the property in the past?  | <input type="checkbox"/> | <input type="checkbox"/> |
| 5. Did you observe evidence or do you have any knowledge that fill material, other than top soil with a maximum depth of 4 feet, was ever brought to the property?   | <input type="checkbox"/> | <input type="checkbox"/> |
| 6. Do you have knowledge of any past or present violations or alleged violations of environmental laws at the property?  | <input type="checkbox"/> | <input type="checkbox"/> |
| 7. To the best of your knowledge, have any studies been prepared to address the impacts of any contamination that may exist on your property on the design, construction, and safe operation of water and sewer systems?   | <input type="checkbox"/> | <input type="checkbox"/> |
| 8. Have you requested the WSSC to prepare on your behalf, and at your expense, a database search conducted per ASTM E-1527?  | <input type="checkbox"/> | <input type="checkbox"/> |

If the answer to question 8 is no, please attach your database search or a Phase I report, per ASTM E-1527. Any Phase I report will be returned to you.

**I HAVE ANSWERED THE ABOVE QUESTIONS TO THE BEST OF MY KNOWLEDGE AND HAVE INCLUDED AN EXPLANATION FOR ANY "YES" ANSWERS. IF APPLICABLE, I HAVE ATTACHED COPIES OF ANY REPORTS REFERENCED IN ITEM 7 ABOVE, OR ALL OF THEIR SECTIONS RELEVANT TO THE DESIGN, CONSTRUCTION, AND SAFE OPERATION OF WATER AND SEWER SYSTEMS. ALSO, I HEREBY ATTEST THAT I HAVE THE AUTHORITY TO SIGN THIS QUESTIONNAIRE AS THE OWNER OR AGENT/ENGINEER OF THE OWNER OF THIS PROPERTY.**

**Contract Number:** \_\_\_\_\_

**Name:** \_\_\_\_\_

**Title:** \_\_\_\_\_

**Signature:** \_\_\_\_\_

**Date:** \_\_\_\_\_

**Owner**

**or**

**Agent/Engineer**



## 25. Tunnels.

### a. General.

- 1) This section discusses the typical situations which require the use of a tunnel for the installation of a water or sewer pipeline.
- 2) The term "tunnel" as used in this section includes, micro tunneling and boring, open cut casing installation and jack and bore casing installations.
- 3) Due to higher construction costs for a tunnel, the first choice of water and sewer pipeline construction is to use the cut and cover method, for additional design guidance see Part Three, Section 19, (Geotechnical Considerations for Pipeline Alignments). However, under certain circumstances and in areas where the requirements of other jurisdictional authorities apply, tunnel construction will be required. If a water or pressure sewer tunnel is required, use a small diameter casing pipe with casing pipe spacers whenever possible, see Standard Details M/17.6 and M/17.7. Microtunneling can be considered in many cases where tunneling is desired or required.
- 4) Tunnel design and submittal requirements; see Part Three, Section 26 (Tunnel Design Criteria) and Section 20 (Geotechnical and Corrosion Submittals).

### b. Conditions and Requirements for Casing pipe.

- 1) Railroad crossing - Consolidated Rail Corporation (Conrail). Refer to the latest edition of the "Specifications for Pipeline Occupancy of Consolidated Rail Corporation Property" (Publication CE-8) for the design of casing pipe crossing a Conrail right of way. Consider the requirements stated under Publication CE-8 and the following:
  - a) Provide on the plans, a specified method of installation, size and material for both the casing and carrier pipes. No alternatives will be allowed.
  - b) Design the casing pipe not less than five and one-half (5-1/2) feet from the **bottom** of the rail to top of the casing pipe at the closest point, except under sidings or industry tracks **where** the distance may be four and one-half (4-1/2) feet, with approval from Conrail.
  - c) Pipelines to be abandoned are to be removed or filled with grout **or flowable fill**, compacted sand or other methods approved by Conrail.
  - d) Design the carrier pipe as either DIP, class 56 or RCP, class V, wall C, ASTM C 76. Steel pipe cannot be used as sewage carrier pipe.
  - e) Extend vent pipes not less than four (4) feet above ground surface.
  - f) Locate the face of all pits a minimum of twenty-five (25) feet from the centerline of the adjacent track, measured at right angles to the tracks.
- 2) Railroad crossing - CSX Transportation, Inc. Refer to the latest edition of "Application for Encroachments Upon the Right of Way of CSX Transportation, Inc", to design casing pipe



crossing CSX property. Consider the requirements stated under Application for Encroachments Upon the Right of Way of CSX Transportation, Inc and the following:

- a) Casing pipe may be omitted for non-pressure sewer crossing where the pipe strength is capable of withstanding railway loading.
  - b) Design mechanical or welded type joints for carrier pipe operating under pressure.
- 3) Railroad crossing - Amtrak. Refer to the latest edition of the "Requirements & Specifications for Pipeline Occupancy of National Railroad Passenger Corporation" (Publication Eng. 1604) for the design of casing pipe crossing Amtrak property. Consider the requirements stated under Publication Eng. 1604 and the following:
- a) Specify only four (4) flange liner plate or RCP, class V, wall C, ASTM C76 for the casing pipe. Smooth wall RCP bells with a nominal diameter of over 54-inch will not be permitted. Do not design liner plate casing pipe for water pipelines.
  - b) Design the carrier pipe as either DIP, class 56 or RCP, class V, wall C, ASTM C 76.
  - c) Do not exceed the outside diameter of the casing pipe by more than one half (1/2") inch, during the over-cutting by the head of the auger in the boring method.
  - d) Block both ends of the casing pipe at the carrier pipe.
  - e) The use of explosives will not be permitted.
- 4) Rail Line crossing Maryland Transit Administration (MTA) Rail Lines.
- a) For requirements, see Part 3, Section 3 (Pipelines Crossings and Clearance).
- 5) Maryland State Highway Administration (MSHA) crossings.
- a) Refer to the latest edition of "Policy on the Accommodation of Utilities on State Highway Rights of Way" published by Maryland State Highway Administration. Provide the option of using jack and bore casing pipes and steel liner plates for tunnel construction.
  - b) Design the carrier pipes within a tunnel for the external loads as if they were not in a tunnel.
- 6) Other road crossings.
- a) Crossing any access, secondary or primary roadway where traffic flow cannot be interrupted as determined by the jurisdictional authority.
  - b) For the design of tunnel construction method options and carrier pipe, see MSHA crossings.
- 7) Right of way crossings.
- a) Crossing the right of way of any county, municipality or utility upon which there exists pavement or other features that may not be disturbed.



- b) If the crossing is short requiring only several lengths of pipes, then the economical tunneling method is to jack and bore a small diameter casing pipe and use casing pipe spacers as the support for the carrier pipe inside the casing, see Standard Details M/17.6 and M/17.7.
- 8) Crossing environmentally sensitive or hazardous waste contaminated areas.
- a) Tunneling may be required when crossing environmentally sensitive or hazardous waste contaminated areas whereby the disturbance to the critical upper soil layer is mandated to be minimized or avoided. Evaluate alternate pipeline alignments to determine the most cost effective and acceptable method for crossing or avoiding these areas.
  - b) In general, the tunnel methods to be used in these areas are the jack and bore casing pipe installation or the earth balanced micro tunneling method.



## 26. Tunnel Design Criteria.

### a. General.

- 1) This section presents the minimum requirements for proposed tunnel designs and extensions to existing tunnels.
- 2) Use this section for soft ground tunnel design criteria only. For rock tunnels criteria, use this section and WSSC will determine additional requirements on a project specific basis.
- 3) The primary objectives of tunnel design must satisfy the following requirements: stability of tunnel openings, protection of adjacent or overlying structures and ability of the tunnel to perform over the intended life.
- 4) The criteria presented in this section are generally applicable to soft ground tunnel design. If conditions are encountered which are not covered in this section, the relevant design criteria are to be established in conjunction with WSSC.
- 5) The term "tunnel" as used in this section includes, micro tunneling and boring, open cut casing installation and jack and bore casing installations.
- 6) For additional requirements; see Part One, Section 17 (Tunnels or Casings) and see Part Two, Section 10 (Tunnels or Casings)

### b. Tunnel Use.

- 1) Whenever possible and agreed to by the affected land owner, the primary choice of WSSC for constructing water and/or sewer pipelines is the cut and cover method. When the conditions stated in "Conditions and Requirements for Tunnels", under Part Three, Section 25 (Tunnels) requires the water and/or sewer pipeline to be in a tunnel, design the tunnel following the criteria in this section.
- 2) Prior to beginning the design, verify with the affected landowner and/or appropriate jurisdictional authority as to whether or not a tunnel crossing is required.

### c. Tunnel or Casing Length.

- 1) Bore and Jack Method.
  - a) Maximum tunnel length is limited to two hundred (200) feet.
- 2) Maryland Transit Administration (MTA) Rail Lines.
  - a) For tunnels crossing a MTA Rail Line, the angle of the crossing is to be based on the economics of the practical alternatives. The crossing is to be located as near perpendicular to the rail line alignment as practical.





b) Minimum length of a tunnel crossing a MTA rail lines is to be as follows:

- (1) At a location where top of the tunnel crosses MTA Rail Line of Influence plus a minimum five (5) feet, see Sketch "VV".

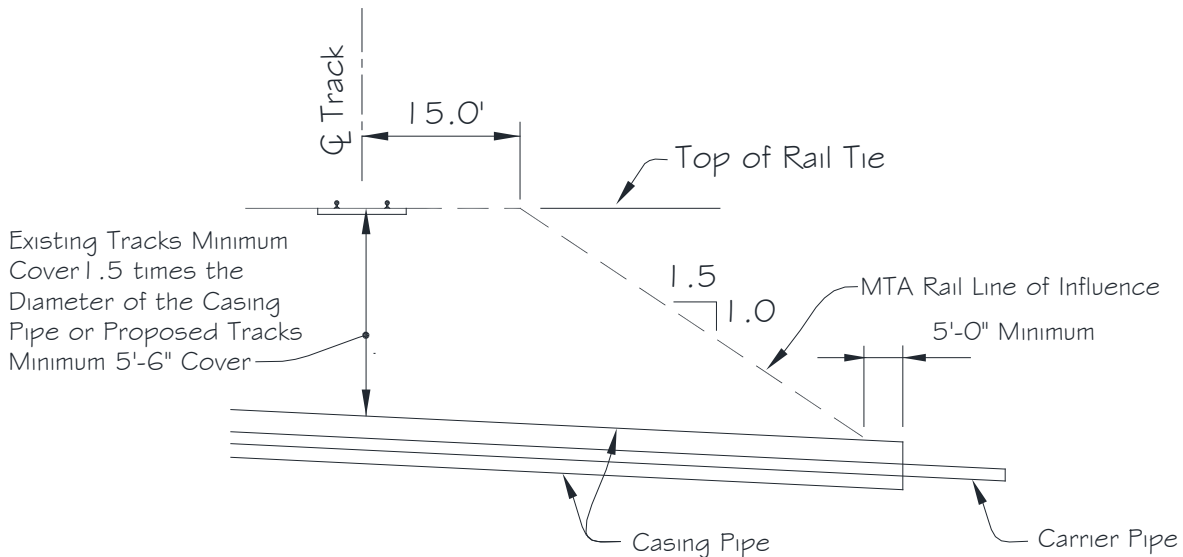

SKETCH "VV"

Profile of Tunnel Crossing MTA Light Rail

- 3) Other railroad or roadway. For tunnels crossing a railroad or roadway, the angle of the crossing is to be based on the economics of the practical alternatives. The crossing is to be located as near perpendicular to the railroad or roadway alignment as practical and the minimum length of tunnel casing is to be the width of the railroad right of way.
- 4) State highways. Minimum casing length of a tunnel crossing a state highway is to be as follows:
- a) The width of the right of way plus five (5) feet for controlled access state highways and interstate highways; see Sketch "FF".
- b) On other state highways:
- (1) The width of the highway (from shoulder to shoulder or paved ditch to paved ditch) plus a horizontal distance measured out from the edges of both shoulders or paved ditches and equal to the elevation difference between the bottom of the pipe and the roadway surface (for shoulder to shoulder case) or the ground surface beside the ditch (for ditch to ditch case) plus five (5) feet.
- (2) If the width of the highway (from shoulder to shoulder or from paved ditch to paved ditch) is much narrower than the width of right of way, the contractor may be given the option of mixed construction using tunneling and open cut excavation within the right of way for



carrier pipe installation. For the remaining part of the right of way, open cut method design the carrier pipe with one (1) class higher than the design requirement, see Sketch "GG".

- c) All tunnels. Extend the length of the tunnel casing beyond the limits of planned future expansion of the surface structure. This distance will be the width of the estimated pressure influence zone outside the planned structure area. As an approximation, the pressure influence zone may be bounded by a forty five (45°) degree line extended outward from the edges of the loading area.

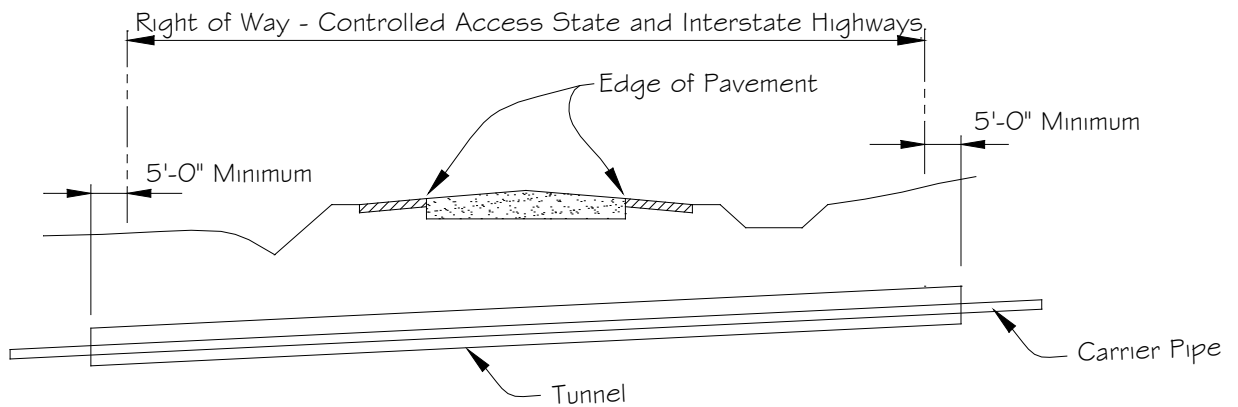

SKETCH "FF"

Profile of Tunnel Crossing MSHA Controlled Access and Interstate Highway

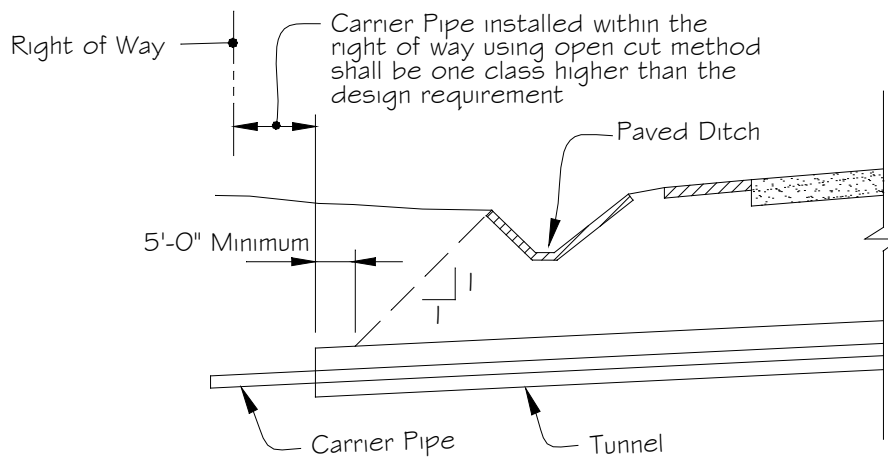

SKETCH "GG"

Profile of Tunnel Crossing MSHA Highway other than Controlled Access and Interstate Highway



**d. Tunnel Casing Diameter.**

- 1) Tunnel diameter requirements using pipe sleeves and casing pipes will vary based on the carrier pipe diameter and the carrier pipe type and contents as follows:
  - a) Tunnel sizes for gravity sewers to be in accordance to Standard Detail M/17.0.
  - b) Tunnel sizes for water pipelines and pressure sewers to be in accordance to Standard Detail M/17.6. In certain ground conditions or in special cases, it may be necessary to use a liner plate or other larger diameter tunnel for a water pipeline or a pressure sewer. See Standard Detail M/17.1 for the tunnel diameters.
  - c) Tunnel diameters for carrier pipe diameters not included in the Standard Details are to be based on ease of installation and maintenance as well as economic considerations, for review and approval by WSSC.
  - d) **Using the bore** and jack method the maximum tunnel length is limited to two hundred (200) feet.

**e. Minimum Soil Cover.**

- 1) The minimum soil cover above the tunnel is to be the greater of four and one half (4-1/2) feet, one and one half (1.5) times the outside diameter of the tunnel or the depth requested by the jurisdictional authority.

**f. Soft Ground Tunneling Methods.**

- 1) Bore and Jack. A method of installing a casing by means of cutting, hand mining or boring an opening in the soil while simultaneously forcing the pipe through the opening with hydraulic jacks. Design the tunnel using steel pipe or reinforced concrete pipe for the casing; see Specifications for casing pipe requirements. The method is limited to a maximum tunnel length to two hundred (200) feet.
- 2) Microtunneling. A method of installing a casing pipe by jacking the casing pipe behind a remotely controlled, steerable, guided Microtunnel Boring Machine (MTBM) which fully supports the excavated face with either slurry or earth pressure balance at all times. Design the tunnel using steel pipe for the casing; see specifications for casing pipe requirements. Alternate casing materials require approval by the Commission.

**g. Clearances with Surrounding Existing Installations.**

- 1) Vertical clearance. Maintain a minimum of two (2) **feet of** clearance between tunnel and other utility lines. The actual location and elevation of the existing utilities over or under the tunnel alignment are to be determined prior to design.
- 2) Horizontal clearance. For tunnels **72-inches** and smaller diameter, maintain (15) **feet of** horizontal clearance between the outside of surrounding surface or subsurface structures/utilities and the outside diameter of the tunnel. **For** tunnels greater than **72-inches in** diameter, determine



the horizontal clearance **and submit calculations to WSSC for approval**; the horizontal clearance **must** be greater than (15) feet.

- 3) Ends of tunnel. The ends of a tunnel are not to be located in steep slopes, streams or drainage ditches. A steep slope is defined as being 3:1 and higher than ten (10) feet **vertically** from the toe to the top of slope. Extend the ends of a tunnel at least fifteen (15) feet beyond the toe of a steep slope.

#### **h. Tunnel Soil Investigation Submittals and Tunnel Geotechnical Report.**

- 1) A tunnel soil investigation is required for all proposed tunnels. A well-planned and detailed tunnel soil investigation is of great importance to the successful design and construction of a tunnel. The investigation is to be planned by a registered professional geotechnical engineer experienced in tunnel design and meet the minimum requirements of Appendix "F", Soil Investigation for Soft Ground Tunnel Projects. Conduct all fieldwork under the continuous inspection of a person experienced in subsurface explorations. Conform to Appendix "F" for all submittals for the tunnel soil investigation.
- 2) Preliminary tunnel submittal **must** contain a natural scale profile of the proposed tunnel (1" = 10'- 0" horizontal and vertical) and **the** tunnel soil investigation submittals specified in Appendix "F".
- 3) Tunnel geotechnical report.
  - a) In general, when a proposed tunnel is greater than 72-inches **in** diameter or a tunnel project appears to be complex such as tunneling in soft clay or loose sand and silt under the water table, a tunnel geotechnical report may be requested to supplement the tunnel soil investigation submittals.
  - b) The necessity of a tunnel geotechnical report for a particular project will be decided by WSSC after the initial review of the preliminary submittal.
  - c) If a tunnel geotechnical report is requested by WSSC, bind the report in a suitable cover, signed and sealed by a registered professional geotechnical engineer, including the following minimum information. All pages are to be marked draft until the report is acceptable to WSSC.
    - (1) All submittals required under Appendix "F" for the tunnel soil investigation.
    - (2) Description of the site, field program and laboratory testing program.
    - (3) Area geology and subsoil conditions.
    - (4) **Recommendation of design if soil borings indicate** groundwater level.
    - (5) Present estimated subsurface profiles and **indicates** groundwater levels **if encountered** along the tunnel alignment.
    - (6) Discuss any special dewatering problems as well as unfavorable soil conditions for tunneling. Propose possible methods of handling these tunnel construction problems including the



limitations and advantages of each **method**.

- (7) Estimation of design pressure due to dead and live loads for the tunnel liner plates.
- (8) Estimation of surface settlements for the ground above and adjacent to the tunnel when it is requested by WSSC.
- (9) Evaluation of the face stability for tunneling. This should be discussed in tunneling terms in accordance with Behavior of Ground at Heading, in this section.
- (10) Recommend the soil parameters as discussed in this section, including but not limited to parameters such as unit weight, friction angle, cohesion or undrained shear strength and effective grain diameter for use in the tunnel access shaft and jacking pit designs.
- (11) **Geotechnical profiles of sections analyzed including tunnel invert elevations**
- (12) **Copies of any other geotechnical report referenced/referred in the report;**
- (13) **Recommended geotechnical special provisions;**
- (14) **Locations plan and results of borings, test pits, rock coring, in-situ and other pertinent geotechnical tests;**

**i. Soil Parameters.**

- 1) Cohesionless soil. Due to the difficulty of obtaining relatively undisturbed samples, the in-situ properties of cohesionless soils are seldom determined in the laboratory. For complex projects where the effort is warranted, commonly accepted field testing methods shall be used. For most projects, the soil parameters may be determined on the basis of local experience or empirical correlation with SPT blow counts and effective grain diameter ( $D_{10}$ ). Some typical empirical correlations are included in Table "25".
- 2) Cohesive soil. Soil parameters such as unit weight, coefficient of permeability and shear strength of cohesive soils may be determined by laboratory testing on undisturbed samples. For a complex project, emphasis on the method of determination shall also be placed on field testing.

**j. Behavior of Ground at Heading.**

- 1) Definitions.
  - a) Firm ground. Heading can be advanced without initial support.
  - b) Raveling ground. Chunks or flakes of material begin to drop out of the arch or walls sometime after the ground has been exposed. "Fast raveling" begins within a few minutes; otherwise the ground is "slow raveling".
  - c) Running ground. Granular materials without cohesion are unstable at a slope greater than their angle of repose. When exposed at steeper slopes they run like granulated sugar or dune sand until the slope flattens to the angle of repose.



- d) Cohesive running ground. Material with sufficient cohesion to stand for a brief period of raveling before it breaks down and runs.
- e) Flowing ground. A mixture of soil and water flows into the tunnel like a viscous fluid. The material can enter the tunnel from the invert as well as from the face, crown, and walls, and can flow for great distances, completely filling the tunnel in some cases.

2) Ground behavior and face stability in various soil conditions.

- a) Plastic clay. For plastic clays at depths not less than approximately two tunnel diameters, the stability of the tunnel face may be evaluated by the following ratio: (Ratio should not exceed six (6) in order to maintain face stability.)

$$(P_z - P_a) \div S_u$$

Where:

$P_z$  = total vertical pressure at depth  $z$  of center of tunnel, (psf)

$P_a$  = air pressure above atmospheric, (psf)

$S_u$  = undrained shear strength of clay, (psf)

b) Silty sands.

- (1) Soils with a unified classification of SP-SM, SW-SM or SM are included in this group. Coarse silt of ML classification may also have similar behavior. The permeability of these soils is commonly moderate to low, in the range of  $10^{-3}$  to  $10^{-5}$  cm/sec.

(2) Above water table.

- (a) The ground behavior may be estimated from the ratio of overburden pressure to unconfined compressive strength if the materials have sufficient cohesion or cementation to permit sampling and testing to define the unconfined compressive strength.
- (b) Firm ground. When the overburden pressure at tunnel depth is in the range of about 1/10 to 1/6 the unconfined strength or less, the ground is likely to be firm.
- (c) Slow raveling. Likely to occur when this ratio is in the range of 1/5 to 1/4.
- (d) Fast raveling. When the overburden pressure is in the range of 1/3 to 1/2 the unconfined strength, the behavior is likely to be fast raveling or worse.
- (e) Estimate of ground behavior based on  $D_{10}$  size. When the soil has too little cohesive strength or cementation to be cored and strength tested, an estimate of ground behavior may be based on effective grain diameter ( $D_{10}$ ) as shown in Figure "D". The figure is drawn for the case of dense soils ( $N > 30$ ) above the water table assuming relatively uniform gradation ( $C_u$  less than 6), and grain shape and packing typical of materials which have experienced moderate transport and working by water. Loose sand ( $N < 10$ ) or sand with very rounded particles would likely exhibit a behavior one to two classes poorer. Soils with very angular particles, significant cementation or relict bonding, or an unusual history such as previous deep burial and compaction, may exhibit behavior one or two classes better.



- (3) Below water table.
- (a) The ground behavior depends upon the external water head, the nature of the fine contents, relative density, soil stratification, rate of excavation advance and other factors.
  - (b) When compressed air is used to control excavation stability, the tunneling system should have the capability of balancing the full external water head at the level of the excavation invert. This is necessary for times when the excavation is stopped. When tunneling with compressed air in clean sands, it is necessary to balance the external water pressure at the level of the lower portion of the tunnel face to prevent excessive water seepage into the invert. If the pressure is balanced at invert level, then at the crown the air pressure is greater than the water pressure, resulting in air losses and drying of sand in the crown. A balance point commonly around the lower 1/4 point of the face is usually selected as a compromise.
  - (c) The estimated bands shown in Figure "E" are intended to represent reasonable lower limits of required air pressure for stability of a tunnel face advancing at a steady rate in the range of thirty two (32) feet per day or more, assuming good construction practice and good ground control.
- c) Clean sand and gravel.
- 1) Above the water table. These soils must be assumed to act as running ground unless the soil investigation shows a significant cementation or a very dense and angular interlocked grain structure in the deposit. For the later case, a raveling ground may be assumed.
  - 2) Below the water table. These soils must be assumed to act as flowing ground. Some form of ground water control such as dewatering or the use of compressed air must be considered. The internal air pressure must approximately balance the external water head.



Compactness	Very loose	Loose	Medium	Dense	Very dense	
Relative density Dd	0	15%	35%	65%	85%	100%
Standard penetration resistance, N= no. of blows per ft	0	4	10	30	50	
Ø (degrees) *		28	30	36	41	
- Unit weight, pcf moist submerged	<100 <60	95-125 55-65	110-130 60-70	110-140 65-85	>130 >75	

\* increase 5 degrees for soils containing less than 5% fine sand or silt.

COHESIONLESS SOIL PROPERTIES AND N VALUES (TENG. 1962)

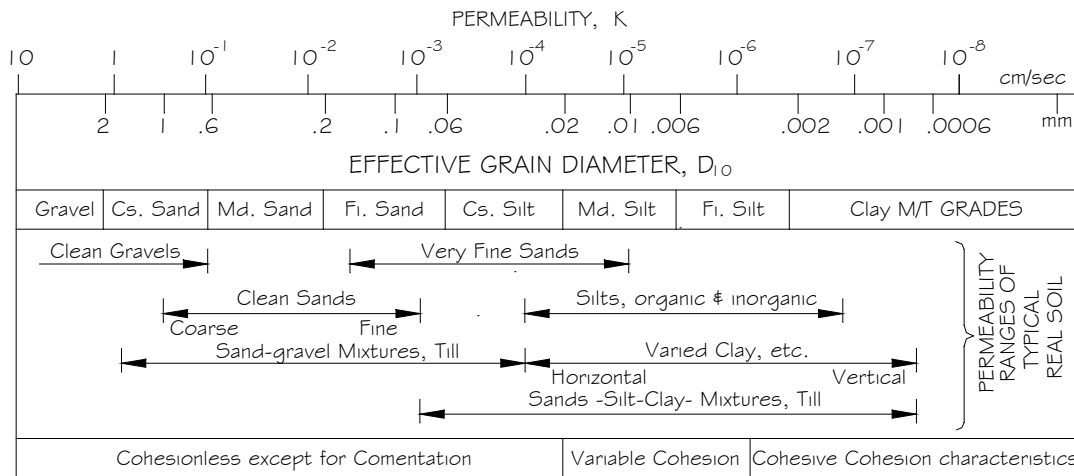

COEFFICIENT OF PERMEABILITY AND D<sub>10</sub> SIZE  
(BICKEL & KUESEL, 1982)

TABLE "25"  
Empirical Correlation of Soils





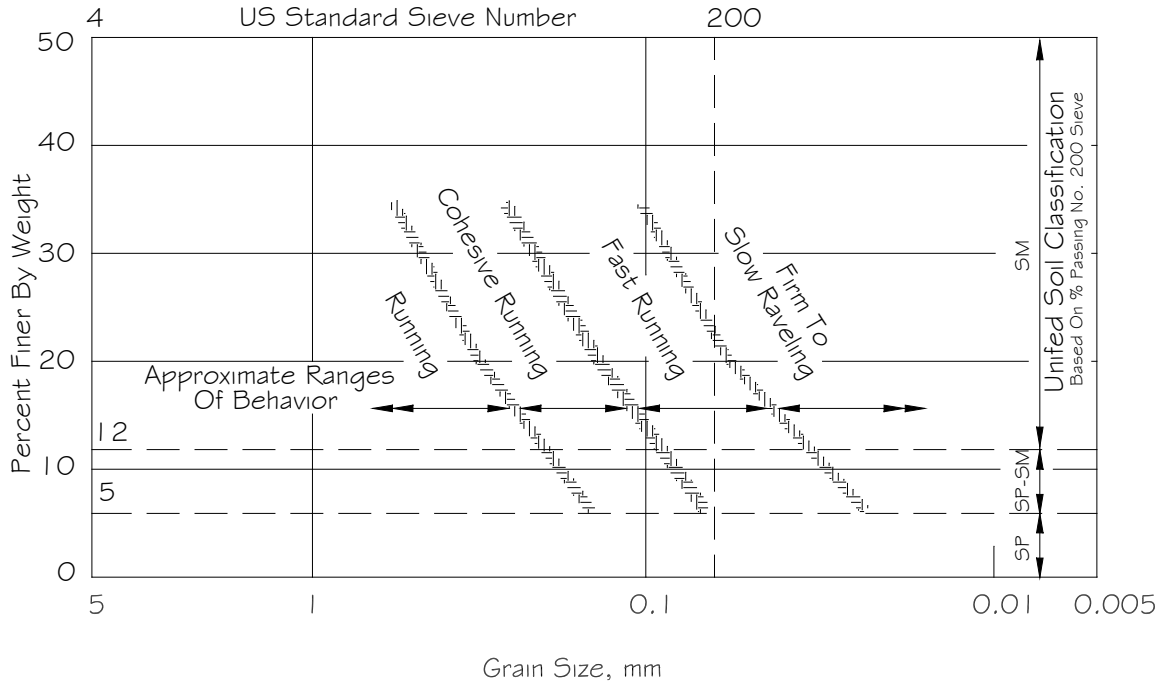

Sand			Silt or Clay
Coarse	Medium	Fine	

Anticipated Ground Behavior Based on  $D_{10}$  Size  
 Dense Soil  $N > 30$ , Above Water Table  
 (HEUR AND VIRGENS, 1987)

FIGURE "D"

Anticipated Ground Behavior Based on  $D_{10}$  Size.

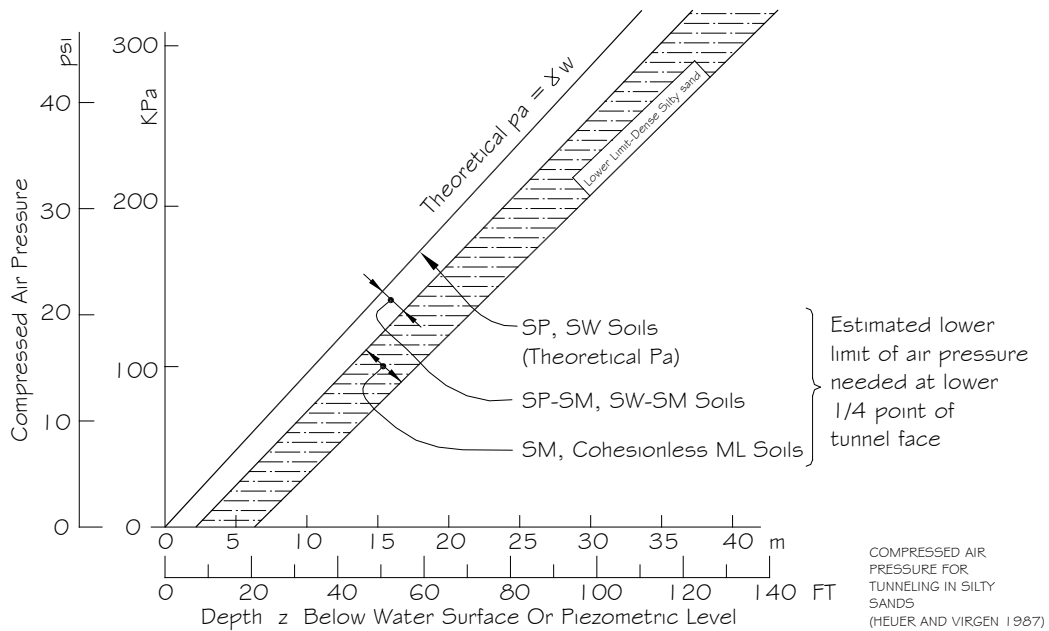

COMPRESSED AIR PRESSURE FOR TUNNELING IN SILTY SANDS  
 (HEUR AND VIRGEN 1987)

FIGURE "E"

Compressed Air Pressure for Tunneling in Silty Sands



**k. Surface Settlement Estimation.**

- 1) Perform surface settlement estimation if it is requested by WSSC after the initial review of the preliminary tunnel submittal, which includes the submitted plan and the soil investigation results. In general, surface settlement analysis may be requested if the soil borings indicate that the tunneling operation will be mainly in soft clay or loose sand and silt under the water table. Settlement analysis may also be requested for tunnel diameters greater than 72-inch in any soil condition or for a proposed tunnel alignment where sensitive structures will be closer than fifteen (15) feet in horizontal direction from the center of the tunnel. Either one of the following methods may be used for the analysis.

- a) Semi-empirical method. The surface settlement trough over a single tunnel may be represented with an error function. The pertinent properties of the error function and its relationship to the dimensions of the tunnel are shown in Figures "F" and "G". Using these figures, the width of the settlement trough is expressed as a multiple of  $i$ . The maximum settlement,  $\delta_{max}$ , above the center of the tunnel may then be estimated from the  $i$  value and the volume of the trough as follows:

$$\delta_{max} = V \div 2.5 i$$

The volume of the trough,  $V$ , in clay may be expressed as:

$$V = 3 (S_u \div E) \text{ EXP} (OF - 1) \quad (\text{For } OF > 1)$$

Where:

$$OF = (P_z - P_a) \div S_u$$

$$P_a = \text{air pressure above atmospheric on the tunnel face (psf)}$$

$$P_z = \text{overburden pressure (psf)}$$

$$S_u = \text{undrained shear strength (psf)}$$

$$E = \text{deformation modulus (psf)}$$

(Note: Usual range of  $(S_u \div E)$  is between 0.002 and 0.005)

The volume of lost ground in sand over a single tunnel is usually estimated from past experience with similar methods of tunnel construction.

- b) Theoretical analysis. A finite element method which simulates tunneling operation and load deformation characteristics of the soils may be used to estimate the soil deformation and surface settlements. The selection of deformation modulus for the soil in the analysis shall be based on local experience, actual field measurements or the estimation from SPT values in accordance with NAVFAC, Soil Mechanics Design Manual, 7.01.



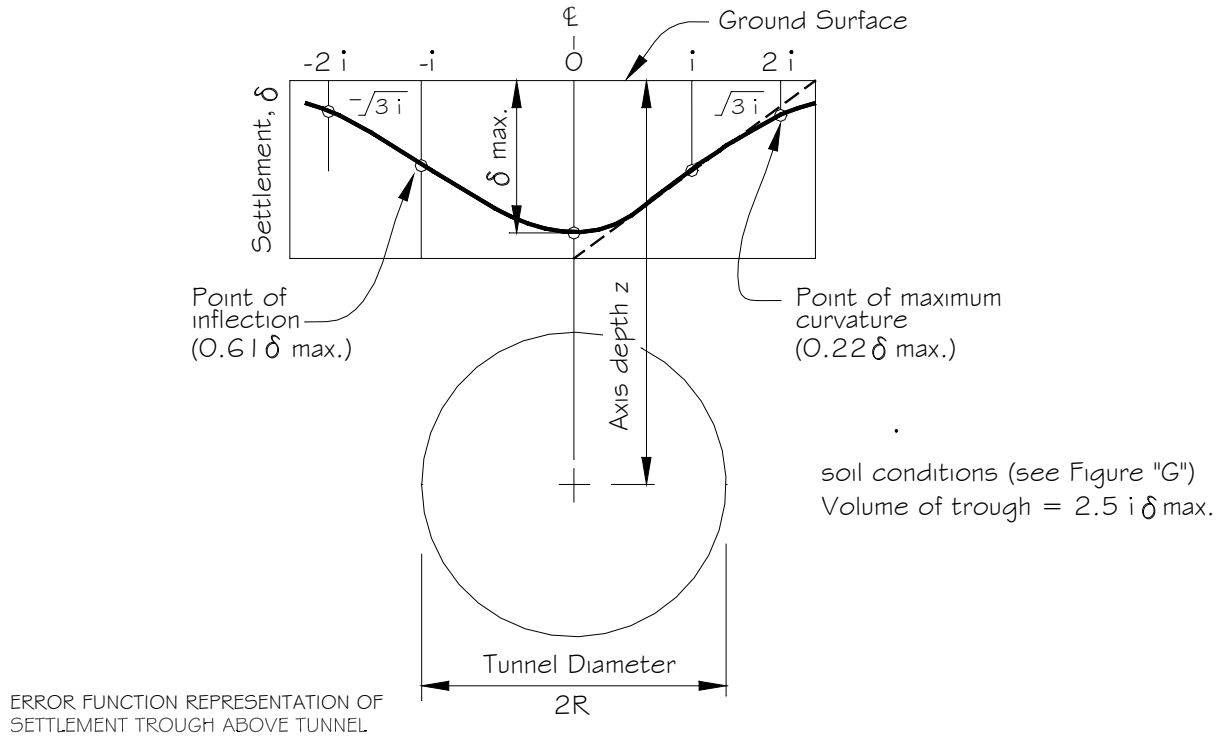
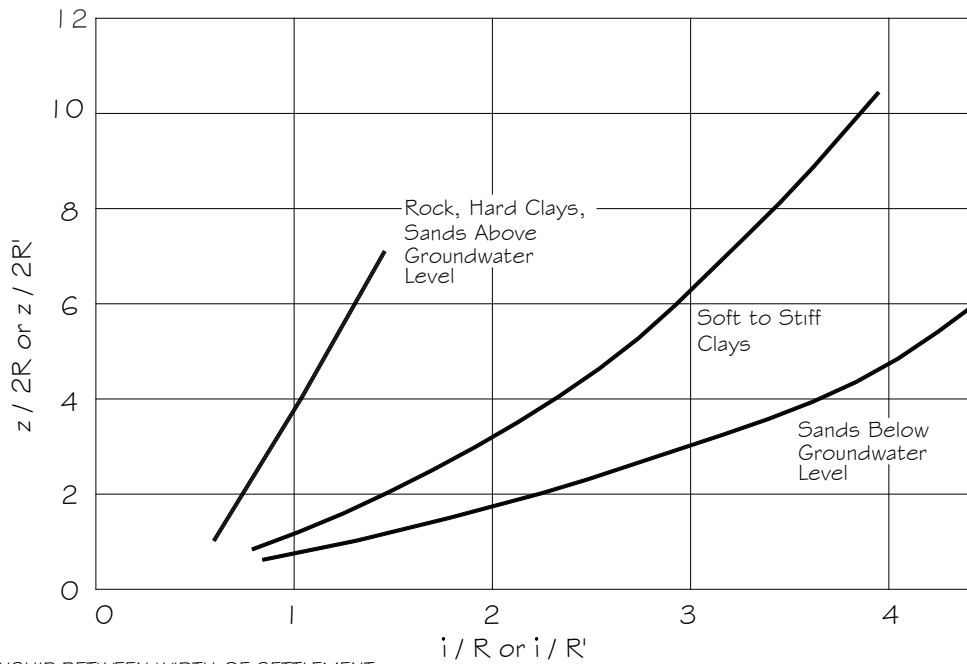

FIGURE "F"

Error Function Representation of Settlement Trough Above Tunnel



RELATIONSHIP BETWEEN WIDTH OF SETTLEMENT TROUGH AND DEPTH OF TUNNEL (PECK, 1969)

FIGURE "G"

Relationship Between Width of Settlement Trough and Depth of Tunnel



**I. Tunnel Design.**

- 1) Design external pressures.
  - a) External pressures acting on a circular tunnel which may be constructed with either liner plates or a casing pipe may be computed approximately with the following procedures.
    - (1) If grouting is used to fill the voids between the tunnel liner and the soil and grouting pressure is greater than the computed external pressures, use grouting pressure for design of the tunnel.
    - (2) In general the external pressure due to earth load, ground water, and live load can be computed by the following formula:

$$P = P_d + P_w + P_l$$

Where:

$P$  = external pressure on the tunnel liner (psf)

$P_d$  = vertical pressure at the level of the top of the tunnel liner due to the soil load (psf)

$P_w$  = water pressure in excess of that considered in the saturated soil load (psf)

$P_l$  = vertical pressure at the level of the top of the tunnel liner due to live loads (psf)

(a) Earth load.

$$P_d = C_d W D$$

Where:

$C_d$  = coefficient of pressure for tunnel liner, (H is height of cover in feet in Figure "H").

$W$  = total unit weight of soil (pcf) (Saturated unit weight for soil below water table.)

$D$  = horizontal diameter of tunnel (ft)

The charts for earth loads on jacked or tunneled installations published in the Concrete Pipe Design Manual by American Concrete Pipe Association (ACPA) can also be used for this purpose. However, the loading obtained from the charts shall be divided by "D" above and furthermore the cohesion term from the charts shall be neglected in the design.



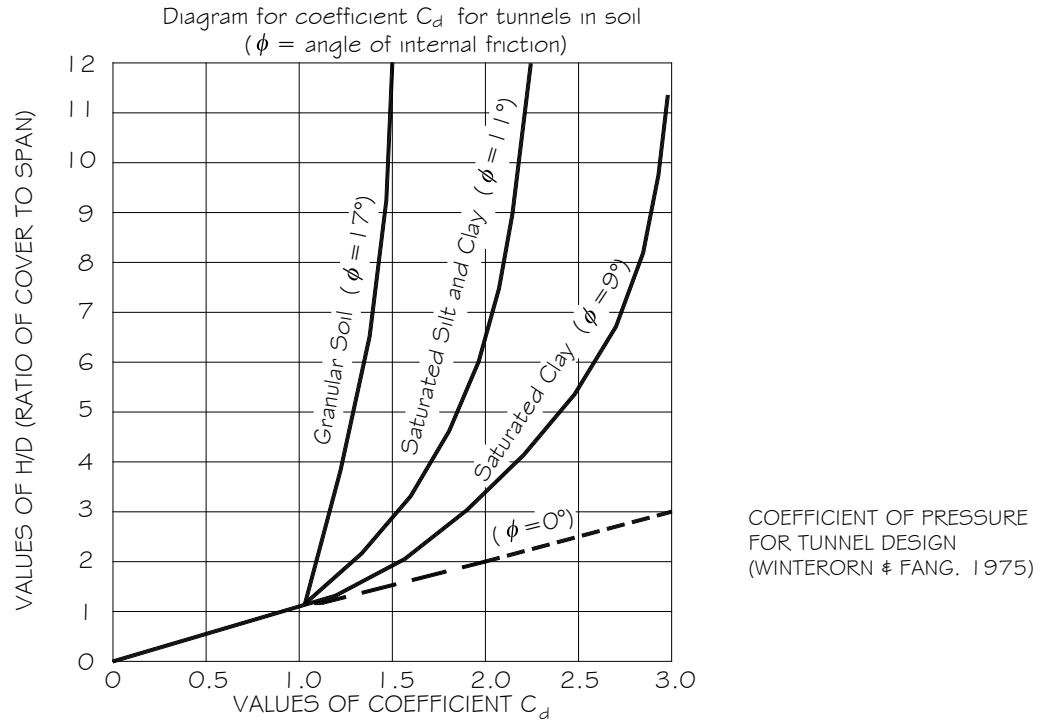

FIGURE "H"

Coefficient of Pressure for Tunnel Design

- (b) Live load. The value of  $P_1$  for both highway and railway loadings can be taken from Table "26", which includes both static and dynamic loading.

TABLE "26"

Value of  $P_1$

Height of Cover (feet)	Highway H20 (psf)	Height of Cover (feet)	Railway E-80 (psf)
1	1800	2	3800
2	800	5	2400
3	600	8	1600
4	400	10	1100
5	250	12	800
6	200	15	600
7	175	20	300
8	100	30	100

The affect of live load less than 100 psf may be disregarded.

- (c) Ground water pressure.

$$P_w = \Gamma_w [h_w - (C_d D)]$$

Where:

$\Gamma_w$  = unit weight of water (pcf)

$h_w$  = height of water surface above the top of the tunnel liner (ft)



This excess water pressure will be included only if  $h_w$  is greater than  $(C_d D)$ . When  $h_w$  is less than  $(C_d D)$ , the water pressure is included in the evaluation of  $P_d$  when the saturated unit weight of soil is used.

2) Design of steel casing pipe.

- a) Consider the following criteria in the design of steel casing pipe. However, under no circumstances shall the wall thickness and the yield strength of the casing pipe be less than 3/8" and 35,000 psi respectively.

(1) Deflection.

$$\Delta x = D_1 \left( (K W_L r^3) \div [(E I) + (0.061 E' r^3)] \right)$$

Where:

- $\Delta x$  = horizontal deflection of pipe (in)
- $D_1$  = deflection lag factor (use 1.5)
- $K$  = bedding constant (0.1)
- $W_L$  = load per unit length of pipe (lb/linear in of pipe); this can be calculated using  $P$ , see Tunnel Design, Design External Pressures, in this Section and is equal to  $PD/12$
- $r$  = radius of pipe (in)
- $E$  = modulus of elasticity of steel ( $29 \times 10^6$  psi)
- $I$  = transverse moment of inertia per unit length of pipe wall ( $\text{in}^3$ ) (equal to  $t^3/12$  where  $t$  is the wall thickness of the pipe)
- $E'$  = modulus of soil reaction ( $\text{lb}/\text{in}^2$ )

The deflection  $\Delta x$  shall be less than three (3%) percent of the pipe diameter.

- (2) Buckling pressure. The allowable buckling pressure may be determined as follows:

$$q_a = (1 \div \text{FS}) \left( 32 R_w B' E' [(E I) \div D^3] \right)^{1/2}$$

Where:

- $q_a$  = allowable buckling pressure (psi)
- $\text{FS}$  = design factor
  - = 2.5 for  $(h/D) \geq 2$
  - = 3.0 for  $(h/D) < 2$
- $h$  = height of ground surface above top of pipe (in)
- $D$  = diameter of pipe (in)
- $R_w$  = water buoyancy factor
  - =  $1 - 0.33 \times (h_w \div h)$ ,  $0 \leq h_w \leq h$
- $h_w$  = height of water surface above top of pipe (in)
- $B'$  = empirical coefficient of elastic support (dimensionless)
  - =  $1 \div (1 + 4e^{(-0.065H)})$
- $H$  = height of fill above pipe (ft)
- $e$  = 2.7183 (constant)
- $E, I$  &  $E'$  are as defined previously, herein

The external pressure  $P$  computed in Design External Pressures in this section shall be equal to or less than  $144 \times q_a$ .



- (3) Jacking force. Design the pipe to withstand the axial stress induced by the jacking operation. The required jacking force may be estimated from the total area of exterior surface of the pipe and the unit friction between the soil and the pipe. The unit friction may be evaluated from the external pressure determined from Tunnel Design, Design External Pressure, in this section, and the pipe weight or it may be estimated from past experience.

3) Design of RCP casing.

- a) Consider the following criteria in the design of the RCP casing: The casing pipe to meet the requirements of ASTM C 76 minimum class IV and for casing pipes crossing under a railroad, meet the requirements of ASTM C 76 Class V with type C wall.

- (1) Selection of pipe strength. The required pipe strength for the external pressure may be determined as follows:

$$D_{0.01} = (P \div L_f) FS$$

Where:

$D_{0.01}$  = 0.01 inch crack D-load (psf)

$P$  = external pressure  $P$  computed in Tunnel Design, Design External Pressure, in this section (psf)

$L_f$  = load factor (use 1.9)

$FS$  = factor of safety (use 1.0 for 0.01 inch crack)

- (2) Jacking force. Design the pipe to withstand the axial stress induced by the jacking operation. The same approach as described in Tunnel Design, Design of Steel Casing Pipe, in this section, can be used for estimation of the jacking force.

- 4) Design of carrier pipe inside the tunnel for the total soil prism load. For railroad crossings, it is further required that the highest class of pipe, DIP Class 56 be used.

**m. Access Shaft and Jacking Pit.**

- 1) As indicated in the Specifications, the design and construction of the access shaft and jacking pit are the responsibility of the contractor. The following information is presented only for reference.

a) Access shaft.

- (1) Locate the access shafts at the low end of the tunnel and a receiving pit at the another end for a short tunnel. The surface area around the shaft needs to be large enough to contain all necessary services and working space such as space for trucks removing muck, space for storage of tunnel lining materials, etc.

(2) Earth pressures.

- (a) In earth pressure calculations, use the total unit weight of soil for the shafts above the water table. For shafts below the water table use the submerged unit weight of soil and add the hydrostatic pressure due to groundwater.



- (b) Surcharge load accounting for the sloping ground surface, adjacent fill, equipment or structures is to be considered in the analysis. In the case where no detailed information is available, assume a minimum of three hundred sixty (360) psf of uniform surface loading beside the shaft.

- [1] Shaft in sand. For a vertical cylindrical shaft, the earth pressure surrounding the shaft may be determined in accordance with the method on pp. 7.1-201 of NAVFAC, 1986, Soil Mechanics Design Manual, 7.01.

For a rectangular or square shape braced excavation the earth pressure on the walls may be calculated following the procedures on pp. 7.2-100 of NAVFAC, 1986, Foundation and Earth Structures Design Manual.

- [2] Shaft in clay. For a cylindrical shaft in soft clay, the earth pressure surrounding the shaft may be evaluated in accordance with the method on pp. 234 of Proctor, R. V. and White, T. L., 1977, Earth Tunneling with Steel Supports, Commercial Shearing, Inc., Youngstown.

The procedure presented on page 7.2-100 NAVFAC, 1986, Foundation and Earth Structures Design Manual, may be used to evaluate the earth pressure for a rectangular or square shape braced excavation.

- 2) Jacking pit. Provide a jacking pit at the lower end of the tunnel when using the bore and jack method. The earth pressure on the jacking pit walls due to the excavation may be calculated similar to the access shaft. Design a reaction backstop suitable to resist the jacking force required to install the casing pipe.

**n. Dewatering.**

- 1) There are several efficient methods of dewatering that may be considered, such as pumping from well points or pumping from deep wells. Required pump capacity may be sized from the estimated coefficient of permeability of the soils. Without previous in-situ test data, the soil permeability may be preliminarily estimated from effective grain diameter ( $D_{10}$ ). Pump size shall then be adjusted as required during construction.
- 2) Well points and deep well pumping are only workable if the percentage of soil particles smaller than 0.05 mm (millimeter) is not more than ten (10) to fifteen (15%) percent. Dewatering by pumping from deep well points can cause varying amounts of settlement. Carefully consider the settlement of ground due to loss of water before using these methods.
- 3) Compressed air methodology may sometimes be used as an alternative to dewatering when ground water draw down is expected to cause excessive settlement.

**o. Casing Seal, Permanent/Temporary Bulkhead or Tunnel Access Manhole.**

- 1) Casing end seals are used at each end of small diameter water and pressure sewer casing which uses casing spacers as shown in Standard Details M/17.6 and M/17.7.
- 2) Provide permanent bulkheads on both ends of large diameter water and pressure sewer tunnels installed according to Standard Detail M/17.1 when the tunnel invert is less than or equal to





- twenty (20) feet. Provide the design for a permanent brick or concrete bulkhead on the plans.
- 3) Provide tunnel access manholes at both ends of large diameter water and pressure sewer tunnels installed according to Standard Detail M/17.1 when the tunnel invert is greater than twenty (20) feet. Provide tunnel access manholes according to Standard Detail M/17.5.
  - 4) For gravity sewer tunnels installed according to Standard Detail M/17.0 that are to be grouted shut, the specifications requires the contractor to provide temporary bulkheads to facilitate grouting the annular space between the carrier pipe and the casing.

**p. Carrier Pipe Tie-Downs.**

- 1) When the annular space between a carrier pipe and casing pipe or tunnel is not grouted shut, such as the case for water pipelines and pressure sewers, provide permanent tie-down assemblies. All types of tie-downs are included in the Standard Details and depend on the material type and size of the tunnel or casing pipe as follow:
  - a) Refer to Standard Detail M/17.2 for hold down assembly for bore and jack steel casing pipes, and Standard Detail M/17.4 for hold down assembly and Standard Detail M/17.4 for hold down assembly for RCP casing pipes.
  - b) Refer to Standard Details M/17.6 and M/17.7 for casing spacers for supporting carrier pipes in small diameter casings installed according to Standard Detail M/17.6.
  - c) For sewer tunnels where the annular space between carrier pipe and the casing or tunnel is to be filled with concrete or grout, temporary supports to prevent pipe flotation are provided in accordance with Standard Detail M/17.0.

**q. Ground Movement Monitoring.**

- 1) Specify the locations of critical structures, surface or subsurface installations to be monitored other than those generally specified for roadway and railroad crossings in the Specifications. Take a minimum of three movement measurements on any critical structures during tunnel construction as follows:
  - a) Tunnel face is ten (10) feet before passing the structure.
  - b) Tunnel face is passing the structure.
  - c) Tunnel face is ten (10) feet beyond the structure.
- 2) Unless a more stringent criteria is required for a specific structure, the maximum allowable settlements or heaves are included in the Specifications.
- 3) Surface settlement markers and subsurface settlement indicators should be installed prior to the tunnel construction. Surface settlement markers can take the form of paint on a concrete surface, pk nail on the paved areas and a wood hub in unpaved areas. Details of subsurface settlement indicators are shown on Standard Detail M/7.0.



**r. Codes.**

- 1) Codes, standards, regulations, and recommended practices.
  - a) The American Society for Testing and Material Standards (ASTM).
  - b) Regulations of the Maryland Department of Transportation, State Highway Administration (MSHA).
  - c) Applicable regulations of affected Railroad Authorities.
  - d) Standard Details.
  - e) Occupational Safety and Health Administration (OSHA) 29 CFR 1926.
  - f) American National Standards Institute (ANSI) A10.16-1995 (R2001), Safety Requirements for Construction of Tunnel Shafts and Caissons.
  - g) American Concrete Institute (ACI) and American Institute of Steel Construction (AISC) Manuals.
  - h) The BOCA Basic Building Code with Montgomery County and Prince George's County Amendments.
  - i) Regulations of the State of Maryland.
  - j) Applicable Regulations of the Federal Government.
  - k) American Association of State Highway and Transportation Officials (AASHTO) Standard Specifications.
  - l) American Railway Engineering Association (AREA) Design Manual.
  - m) NACE International Recommended Practices.

**s. References.**

- a) Proctor, R. V. and White, T. L., 1977, Earth Tunneling with Steel Supports, Commercial Shearing, Inc., Youngstown.
- b) Peck, R. B. et.al., November 1969, Some Design Considerations in the Selection of Underground Support Systems, Department of Civil Engineering, University of Illinois, Urbana.
- c) Peck, R. B., 1969, Deep Excavations and Tunneling in Soft Ground, State of the Art Volume, 7th International Conference on Soil Mechanics and Foundation Engineering, Mexico City, pages 225 to 290.
- d) Commercial Pantex Sika, Inc., Soft Ground Tunneling Catalog.



- e) Warren Consolidated Industries, Inc., Tunnel Liner Plates Catalog.
- f) Golder Associates and James F. Maclaren Ltd., 1976, Tunneling Technology: An Appraisal of the State of the Art for Application to Transit Systems.
- g) Bickel, J. O. and Kuesel, T. R., 1982, Tunnel Engineering Handbook, Van Nostrand Reinhold Co.
- h) NAVFAC, 1986, Soil Mechanics Design Manual 7.01.
- i) NAVFAC, 1986, Foundation and Earth Structures Design Manual 7.02.
- j) NAVFAC, 1982, Soil Dynamics, Deep Stabilization and Special Geotechnical Construction Design Manual 7.3.
- k) Heuer, R.E. and Virgens, D.L., 1987, Anticipated Behavior of Silty Sands in Tunneling, Proceedings Volume 1, Rapid Excavation and Tunneling Conference, New Orleans, Louisiana, June 14-18, pages 221-237.
- l) Winterkorn, H.F. and Fang, H.Y., 1975, Foundation Engineering Handbook, Van Nostrand Reinhold Company.
- m) TENG, W.C. 1962, Foundation Design, Prentice Hall, Inc., Englewood Cliffs, N.Y.
- n) Spangler, M.G. & Handy, R.L., 1982, Soil Engineering, Harper & Row Publishers, N.Y.



## 27. Thrust Restraint Design for Buried Piping.

### a. General.

- 1) This section presents the design methodology to be used when providing thrust restraint for buried pressurized piping. It includes guidelines for the design of thrust **restrains for concrete blocking and** restrained joint pipe.
- 2) In a pressurized buried pipeline such as a water main or sewage force main, thrust forces act on the pipe where changes in fluid velocity, changes in pipe size or changes in pipeline direction occur. This is generally at fittings such as plugs, caps, valves, tees, bends or reducers.
- 3) Thrust forces may also occur at the locations where new pipe is connected in-line to a different type of existing pipe with different sealing diameters. A significant example of this is the connection of large diameter Prestressed Concrete Cylinder Pipe (PCCP) and Ductile Iron Pipe (DIP). A thrust force is created at this type of connection in the same manner as a reducer; see Unbalanced Thrust at Connections to Existing Water Pipelines, in this section.
- 4) **Do not design concrete thrust blocking on existing Prestressed Concrete Cylinder Pipe (PCCP); see Standard Detail B/3.1b.**

### b. General Requirements for Concrete Thrust Blocks.

- 1) Always consider the thrust forces in the design of buried pressurized pipelines, since it may cause separation of the joints and leakage of the pipeline. The most fundamental approach to resist a thrust force is to install a non-reinforced poured-in-place concrete block at the fitting.
- 2) The basic type of non-reinforced concrete block used for bends, tees, plugs and caps is referred to here as a concrete thrust block, but may also be referred to as an anchorage or buttress.
- 3) When concrete thrust blocks are used for fittings in close proximity to each other, ensure that no part of the blocks overlaps and that the passive pressure soil zones do not overlap which could cause construction problems or block failure. See Passive Soil Pressure for Concrete Thrust Blocks, in this section.
- 4) Locate the thrust block such that its passive pressure zone of influence does not affect other utilities or structures.
- 5) Provide a minimum soil cover of one (1) foot over all thrust blocks. For thrust blocks in existing or proposed roads or road rights of way, provide a minimum one and one half (1-1/2) feet of soil cover, unless otherwise directed or approved.

### c. Standard Design for Concrete Thrust Blocks.

- 1) Thrust blocks for pipelines 16-inch and smaller.
  - a) The dimensions and design details for concrete thrust blocks for pipe sizes 16-inch and smaller diameter are provided in the Standard Details. As long as the conditions which are specified in the notes on the blocking standard details are met for the particular application, then the



standard detail applies and can be simply referenced on the contract drawings. If any of the conditions on the standard detail cannot be met, then special design blocking is required as indicated below. Also, see Part Three, Section 6, Modifications to Specifications and Standard Details.

- b) If the design pressure for the project is significantly less than the design pressure used for the standard detail blocking, such as for low pressure treatment plant process piping, sewage force mains, etc., then evaluate the economics of downsizing the standard detail blocking accordingly, depending on the number of blocks required, design costs, etc. If the design requires the standard details to be modified, see the requirements for Special Design Concrete Thrust Blocks indicated below.

2) Soil investigation requirements for the use of standard design blocking.

- a) A soil boring is generally required near the proposed thrust block location; see Part Three, Section 20, Geotechnical and Corrosion Submittals, for soil boring location **and submittal** requirements. Use the information on the boring logs to confirm items b) and c) below, prior to using the blocking standard details.
- b) Elevation of groundwater table must be below the bottom of the block for upper vertical bends or the invert of the pipe for all other blocks. If the actual groundwater table is higher than the above, then evaluate the standard block size for submerged conditions and note that a special design block may be required.
- c) The soil at the proposed thrust block location and elevation shall not be soft with standard penetration test blow count (N) equal to or less than four (4), nor shall the soil be organic. If these conditions exist, then special design blocking is required. Other alternatives such as replacing the in-situ soil with structural fill within the zone of influence of the thrust block or restraining the pipe instead of using a block may also be considered.

**d. Special Design for Concrete Thrust Blocks.**

- 1) Pipe larger than 16-inch diameter and other cases not covered by the Standard Details. Special design blocking is required according to the guidelines in this section. Submit special design calculations, which are signed and sealed by a State of Maryland registered professional engineer, for each special design along with the drawings (plan and profile). In general, the special design dimensions can be called out on the drawings for the variable dimensions shown on the standard details without providing a detail of the block on the drawings. For information on changing specifications and standard details, see Part Three, Section 6 (Modifications to Specifications and Standard Details).

2) Guidelines for special design blocking are as follows:

- a) Soil investigation requirements for special design blocking.

- (1) Soil boring is required at or near the proposed location of the special design thrust block. Extend the soil boring below the invert of the pipe at least ten (10) feet, or to the estimated base elevation of the thrust block, whichever is greater.

- (2) Perform Standard Penetration Tests (SPT) at two and one half (2.5) foot intervals for the



upper ten (10) feet of the boring and then every five (5) feet thereafter. If cohesive soils are encountered, obtain undisturbed samples near the springline of the pipe. Perform confined compression strength and Atterberg limit tests on the samples.

- (3) The soil boring along with the laboratory tests shall provide sufficient information to determine the following:
- (a) Classification of soils in accordance with the Unified Soil Classification System (ASTM D 2487).
  - (b) Field density from SPT and shear strength from unconfined compression tests or SPT.
  - (c) Coefficients of lateral earth pressure.
  - (d) Groundwater level, at completion and at twenty four (24) hours after the completion of the boring and removal of the augers and any casings.
- b) Block configuration. Thrust blocks shall generally be configured similar to those shown in the standard details. A rectangular shaped front face shall be used for the blocks for horizontal bends, reducers, tees, plugs and caps if possible. The reasonable range of depth to width ratio for the rectangular face shall be between 1 and 3.
- c) Internal design pressure.
- (1) Water pipelines. Compute the total internal design pressure used for blocking design according to Part One, Section 5 (Total Internal and Transient Pressures). Generally, the thrust restraint is designed for the total pressure. Under some special circumstances, the necessary test pressure may be lower or higher than this total pressure. Consult WSSC as to which pressure is to be used for the thrust restraint design.
  - (2) Pipelines other than water pipelines. Determine the total internal design and test pressure for pipelines other than water pipelines, such as sewage force mains, treatment plant pressure piping, etc., and use the appropriate pressure for the special design blocking.
- d) Design thrust force (F) for fittings.
- (1) When calculating thrust forces, use the outside diameter (OD) or joint sealing diameter. The sealing diameter is the internal diameter of the gasket at the bell, where the internal water pressure comes in contact.
  - (2) Horizontal (HB), Upper Vertical (UVB) and Lower Vertical (LVB) Bends. Calculate the design thrust force or resultant force for bends.

$$F = 2 P A \sin (\Theta \div 2)$$

Where:

- P = design pressure
- A = cross sectional area of pipe
- Θ = angle of the bend



- (3) Plugs and caps. Use the full thrust force, which is equal to the design pressure (P) times the cross sectional area (A) of the pipe. ( $F = P A$ )
- (4) Tees, TS&V. Use the full thrust force, which is equal to the design pressure (P) times the cross sectional area (A) of the branch pipe. ( $F = P A$ )
- (5) Reducers. The design thrust force for reducers is equal to the design pressure (P) times the difference of the cross sectional areas of the large ( $A_1$ ) and small end ( $A_s$ ) sizes of the reducer.  $F = P (A_1 - A_s)$
- e) Appropriate earth pressure theories to be used when designing thrust blocks.
- (1) Horizontal bends, reducers, tees, TS&V, plugs and caps.
- (a) Design horizontal bends, reducers, tees, TS&V, plugs and caps using one of the appropriate earth pressure theories indicated below and state the specific references used in the design calculations.
- Design Method for Vertical Anchor Slabs in Sand, N. Krebs Ovesen and Helle Stromann. See pages 1481 to 1500, Performance of Earth and Earth-Supported Structures, Volume 1 Part 2, ASCE, 1972.
- Design for Unbalanced Thrust for Buried Water Conduits, Charles A. Manganaro, see pages 705 to 716, Journal AWWA, June 1968.
- (b) Do not use a design concept based on bearing capacity.
- (c) For blocks in cohesive soils, evaluate the soil resistance in terms of short and long term shear strengths and use the lowest resistance between the two for the design.
- (d) Calculated net soil resistance for the block is to be at least 1.5 times the design thrust force.
- (2) Upper vertical bends. Design the thrust blocks for upper vertical bends such that the sum of the effective weight of the concrete, bend and fluid is equal to or greater than the vertical component of the design thrust force.
- (3) Lower vertical bends. Design the thrust blocks for lower vertical bends such that the contact pressure at the bottom of the block is within the allowable soil bearing capacity.

**e. Design Example: Horizontal Bend Concrete Thrust Blocks.**

Determine size of a thrust block required for a 30"-1/8 (45°) HB at Station 0 + 00.

For this example, "Ovesen and Stromann" method was used.

Design Parameters:

Ground surface elevation at the fitting = 134.4      Fitting invert elevation = 127.4.

HHG (High Hydraulic Grade) = 325 ft      Surge pressure = 80 lb/in<sup>2</sup>

Pipe outside diameter (OD) = 32.00 inches (ANSI/AWWA C150/A21.50)

For obtaining HHG and surge pressure, see Part One, Section 5 (Total Internal and Transient Pressures).



Determine the passive soil pressure zone.

A review of the plans reveals that there are no existing or proposed utilities, structures, etc., anywhere close to the passive pressure soil zone behind the proposed thrust block, see Passive Soil Pressure for Concrete Thrust Blocks, in this section.

Determine if special detail is required.

Standard Detail B/1.0 for horizontal bends thrust blocks only includes up to 16-inch diameter water mains, therefore, this is a special design. Design the block using the same general block configuration as the standard detail and determine the required special design dimensions. If the assumptions and limitations indicated in the "notes" on the standard detail are consistent with the particular special design, then generally the special design dimensions can be indicated in a note on the contract drawings referencing Standard Detail B/1.0 without providing a detail of the block on the plans. This is true for this case, therefore the special design dimensions are determined as follows:

Determine soil design parameters.

A soil boring located at the proposed fitting supports the following soil design parameters:

Silty Sand	No Groundwater
$\gamma$ = soil unit weight	= 120 lb/ft <sup>3</sup>
$\phi$ = soil friction angle	= 25°
$k_a$ = active earth pressure coefficient	= 0.41
Where $k_a = (1 - \sin \phi) \div (1 + \sin \phi)$	

For soil boring requirements, see Part Three, Section 20, (Geotechnical and Corrosion Submittals).

Determine design pressure:

$$P = \text{design (total) pressure} = ((\text{HHG} - \text{pipe invert}) \times 0.433) + \text{surge}$$

$$= ((325 - 127.4) \times 0.433) + 80$$

$$P = 165.63 \text{ lb/in}^2$$

Determine thrust force - Horizontal Bend:

$$R = \text{thrust (resultant horizontal force)} = 2 P A \sin (\Theta \div 2)$$

Where:

$$P = \text{design (total) pressure}$$

$$A = \text{pipe cross sectional area} =$$

$$= (\pi \times (\text{OD})^2) \div 4$$

$$= (3.1415927 \times (32.00)^2) \div 4$$

$$A = 804.25 \text{ in}^2$$

$$\Theta = 45^\circ \text{ (for a 1/8 HB)}$$

$$R = 2 (165.63 \text{ lb/in}^2) (804.25 \text{ in}^2) \sin (45^\circ \div 2)$$

$$R = 101,952.93 \text{ lb}$$





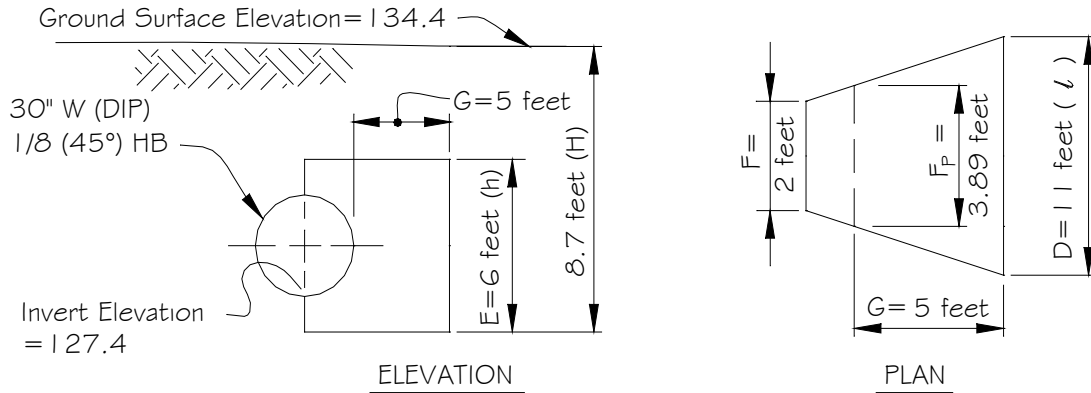

SKETCH "II"

Example of Concrete Thrust Block For Horizontal Bend

Assume a block size and determine the weight of the proposed block per foot width:

wt = weight of the concrete block/ft width  $\gamma_c = 150 \text{ lb/ft}^3$  (unit weight of concrete)

Using Standard Detail B/1.0, assume the following block dimensions, see Sketch "KK":

$F = 2 \text{ feet}$     $E = 6 \text{ feet}$     $D = 11 \text{ feet}$     $G = 5 \text{ feet}$     $F_p = 3.89 \text{ feet}$

$\text{wt} = G E ((F_p + D) \div 2) \gamma_c = 5 \text{ ft} \times 6 \text{ ft} \times ((3.89 \text{ ft} + 11 \text{ ft}) \div 2) \times 150 \text{ lb/ft}^3$   
 $= 223.35 \text{ ft}^3 \times 150 \text{ lb/ft}^3 = 33,502.5 \text{ lb} \div \text{width} = 33,502.5 \text{ lb} \div 11 \text{ ft}$

$\text{wt} = 3045.68 \text{ lb/ft}$

Determine normal active earth pressure:

$E^a =$  normal active earth pressure  
 $= \frac{1}{2} \gamma H^2 k_\gamma^a$   
 $= \frac{1}{2} \times 120 \text{ lb/ft}^3 \times (8.7 \text{ ft})^2 \times 0.41$   
 $E^a = 1861.97 \text{ lb/ft}$

Determine tangential active earth pressure:

$F^a =$  tangential active earth pressure  
 $= E^a \tan \square$   
 $= 1861.97 \text{ lb/ft} \tan 25^\circ$   
 $F^a = 868.25 \text{ lb/ft}$

Determine earth pressure coefficient for tangential earth pressure in front of block:

$k_\gamma \tan \delta_\gamma =$  earth pressure coefficient for tangential earth pressure in front of block  
 $= (G + F^a) \div (\frac{1}{2} \gamma H^2)$   
 $= (3045.68 \text{ lb/ft} + 868.25 \text{ lb/ft}) \div (\frac{1}{2} \times 120 \text{ lb/ft}^3 \times (8.7 \text{ ft})^2)$   
 $k_\gamma \tan \delta_\gamma = 0.86$

Determine earth pressure coefficient for normal earth pressure in front of block:

$k_\gamma =$  earth pressure coefficient for normal earth pressure in front of block  
 Obtain from Figure "J", for ( $k_\gamma \tan \delta_\gamma = 0.86$  and  $\square = 25^\circ$ )  
 $k_\gamma = 3.25$

Determine anchor resistance:

$A^o =$  anchor resistance  
 $= (\frac{1}{2} \gamma H^2 k_\gamma) - E^a$   
 $= (\frac{1}{2} \times 120 \text{ lb/ft}^3 \times (8.7 \text{ ft})^2 \times 3.25) - 1861.97 \text{ lb/ft}$   
 $= 14,759.55 \text{ lb/ft} - 1861.97 \text{ lb/ft}$   
 $A^o = 12,897.58 \text{ lb/ft}$



Determine effective block length:

$l^e$  = effective block length.

$$(l^e - l / H + h) = (11 - 1) \div (8.7 + 6)$$

$$(l^e - l) \div (H + h) = 0.24 \quad \text{Obtain from Figure "K", for } 0.68$$

$$l^e = 0.24 \times (H + h) + l \quad \text{(rearrange terms to solve for } l^e \text{)}$$

Where:

$$h \text{ (assumed block height)} = 6 \text{ feet} \quad H \text{ (depth to bottom of block)} = 8.7 \text{ feet}$$

$$l \text{ (assumed block length)} = 11 \text{ feet}$$

$$l^e = 0.24 \times (6 \text{ ft} + 8.7 \text{ ft}) + 11 \text{ ft}$$

$$l^e = 14.53 \text{ feet}$$

Determine anchor resistance ratio:

$A^s / A^o$  = anchor resistance ratio

Obtain from Figure "I", for  $(h / H = 6 \div 8.7 = 0.69)$

$$A^s / A^o = 0.95$$

Determine the anchor resistance or load capacity of block:

$Q$  = anchor resistance

$$= A^o (A^s / A^o) l^e$$

$$= 12,897.58 \text{ lb/ft} \times 0.95 \times 14.53 \text{ ft}$$

$$Q = 178,031.75 \text{ lb}$$

Determine factor of safety of assumed block size:

FS = Factor of Safety = 1.5

$$= Q \div R$$

$$= 178,031.75 \text{ lb} \div 101,952.93 \text{ lb}$$

$$FS = 1.74 > 1.5 \therefore \text{O.K.}$$

Summary: The assumed block size is adequate, provide this note, either in the "Blocking Notes" or the "General Notes". "Block 30"-1/8 HB at Station 0+00 with concrete according to Standard Detail B/1.0 using the following block dimensions: D = 11'-0", E = 6'-0", F = 2'-0" and G = 5'-0."



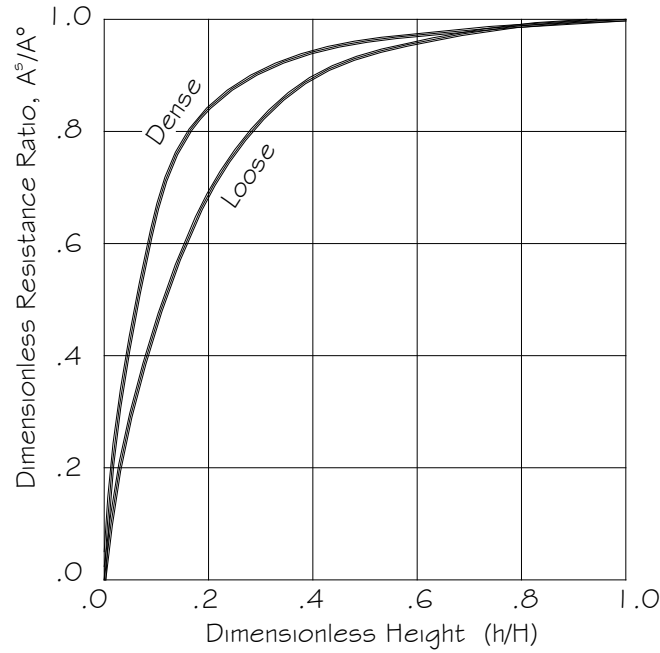

FIGURE "I"

Dimensionless Anchor Resistance Ratio,  $A^s/A^o$

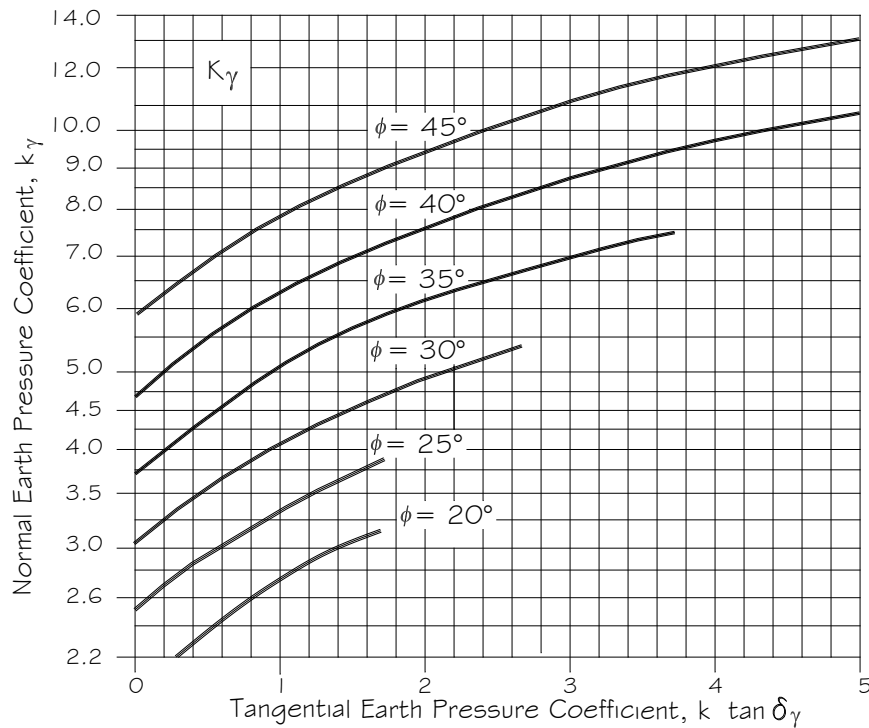

FIGURE "J"

Earth Pressure Coefficient for Normal Earth Pressure in Front of Block



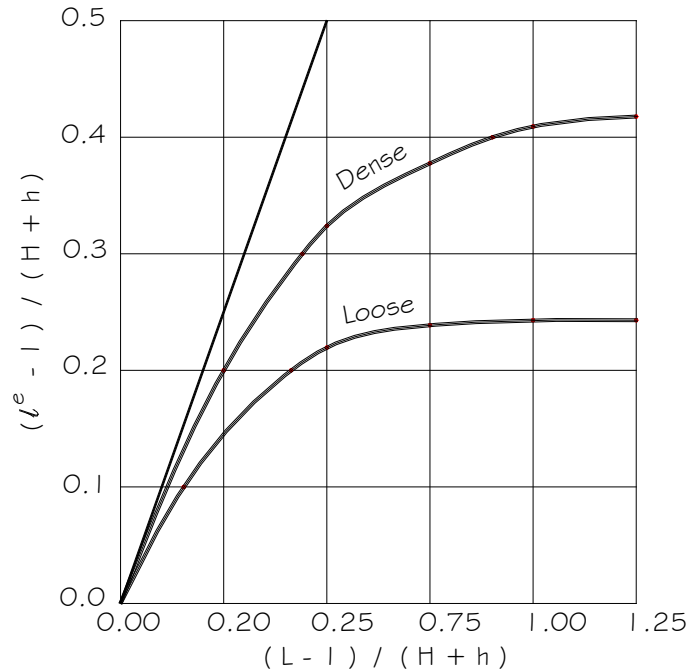

FIGURE "K"

Dimensionless Anchor Resistance Ratio,  $(l^e - 1) / (H + h)$ **f. Design Example: Upper Vertical Bend Concrete Thrust Blocks.**

Determine size of a thrust block required for a 30"-1/8 (45°) UVB at Station 1 + 00

Ground surface elevation at the fitting = 134.4      Fitting invert elevation = 127.4.

HHG (High Hydraulic Grade) = 325 ft      Surge pressure = 80 lb/in<sup>2</sup>

Pipe outside diameter (OD) = 32.00 inches (ANSI/AWWA C150/A21.50)

For obtaining HHG and surge pressure, see Part One, Section 5 (Total Internal and Transient Pressures).

Determine if special design is required.

Standard Detail B/1.7 for upper vertical bend thrust blocks only includes up to 16-inch diameter water mains, therefore this is a special design. Design the block using the same general block configuration as the standard detail and as shown on Sketch "JJ". Determine minimum dimensions of the concrete block needed to offset the vertical component of the thrust, generated by the 30"-1/8 UVB. The final shape of the block will need to be determined based on its constructability.

Determine soil design parameters.

A soil boring located at the proposed fitting supports the following soil design parameters:

Silty Sand      High Groundwater, Submerged Condition

For soil boring requirements, see Part Three, Section 20 (Geotechnical and Corrosion Submittals).

Determine design pressure:

$P = \text{design (total) pressure} = ((\text{HHG} - \text{pipe invert}) \times 0.433) + \text{surge}$

$= ((325 - 127.4) \times 0.433) + 80$

$P = 165.63 \text{ lb/in}^2$



Determine thrust force

$$R_v = \text{thrust (resultant force)} = 2 P A \sin (\Theta \div 2)$$

$$\text{Where: } P = \text{design (total) pressure} \quad A = \text{pipe cross sectional area} \\ = (\pi \times (\text{OD})^2) \div 4$$

$$\Theta = 45^\circ \text{ (for a } 1/8 \text{ HB)} \quad = (3.1415927 \times (32.00)^2) \div 4 \\ A = 804.25 \text{ in}^2$$

$$R_v = 2 \times (165.63 \text{ lb/in}^2) \times (804.25 \text{ in}^2) \times \sin (45^\circ \div 2)$$

$$R_v = 101,952.93 \text{ lb}$$

Ground Surface Elevation = 134.4

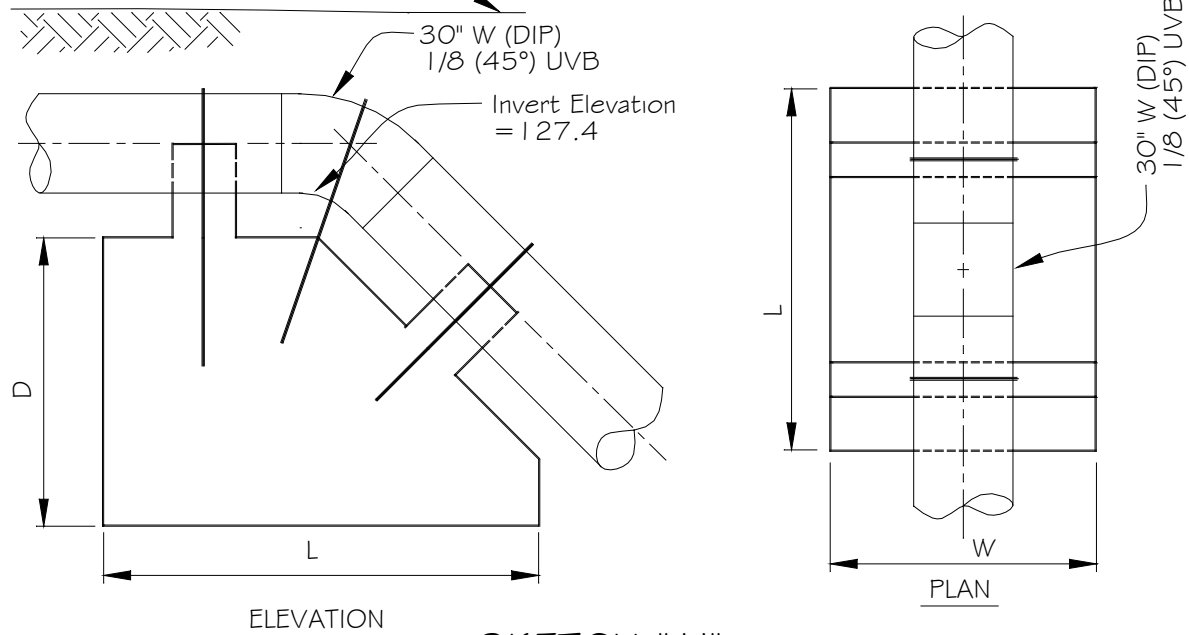

Example of Concrete Thrust Block For Upper Vertical Bend

Assume a block size and determine the weight of the proposed block:

$$W_b = \text{weight of the concrete block} \quad \gamma_w = 62 \text{ lb/ft}^3 \quad (\text{unit weight of water}) \\ \gamma_c = 150 \text{ lb/ft}^3 \quad (\text{unit weight of concrete})$$

Using Sketch "LL" and Standard Detail B/1.7, assume the following block dimensions:

$$D = 9 \text{ feet} \quad L = 12 \text{ feet} \quad W = 12 \text{ feet} \\ W_b = L W D (\gamma_c - \gamma_w) \\ = 12 \text{ ft} \times 12 \text{ ft} \times 9 \text{ ft} \times (150 \text{ lb/ft}^3 - 62.4 \text{ lb/ft}^3) = 1296 \text{ ft}^3 \times 87.6 \text{ lb/ft}^3 \\ W_b = 113,529.6 \text{ lb}$$

Determine factor of safety of assumed block size:

$$\text{FS} = \text{Factor of Safety} = 1.0 \\ = W_b \div R_v = 113,529.6 \text{ lb} \div 101,952.93 \text{ lb} \\ \text{FS} = 1.21 > 1.0 \therefore \text{O.K.}$$

Determine size of reinforcing bars for strapping pipe to the block:

$$R_v = 101,952.93 \text{ lb}$$



Using grade 60 reinforcing bars, allowable tensile shear in reinforcement,  $f_s = 24,000\text{psi}$

Required area of the reinforcing with 1.5 safety factor (FS)

$$A_{\text{required}} = \text{FS} \times (R \div f_s) = 1.5 \times (101,952.93 \text{ lb} \div 24,000\text{psi})$$

$$A_{\text{required}} = 6.38 \text{ in}^2$$

Using 4 #10 reinforcing bars as shown on Standard Detail B/1.7

$$A_{\text{provided}} = ((\# \text{ of bars}) \times 2 \text{ (each side of bar embedded in block)} A_{\text{bar}}) > A_{\text{required}}$$

$$= (4 \times 2 \times 1.27 \text{ in}^2) > 6.38 \text{ in}^2$$

$$A_{\text{provided}} = 10.16 \text{ in}^2 > 6.38 \text{ in}^2 \quad \therefore \text{O.K.}$$

Summary: The assumed block size is adequate. Adjust the size of the with the block configuration shown in Sketch "JJ". Provide a detail on the drawings typical to Sketch "JJ" and Standard Detail B/1.7.

**g. Design Example: Lower Vertical Bend Concrete Thrust Blocks.**

Determine size of a thrust block required for a 30"-1/8 (45°) LVB at Station 2 + 00

Ground surface elevation at the fitting = 134.4      Fitting invert elevation = 127.4.

HHG (High Hydraulic Grade) = 325 ft      Surge pressure = 80 lb/in<sup>2</sup>

Pipe outside diameter (OD) = 32.00 inches (ANSI/AWWA C150/A21.50)

For obtaining HHG and surge pressure, see Part One, Section 5 (Total Internal and Transient Pressures).

Determine if special design is required.

Standard Detail B/1.8 for lower vertical bend thrust blocks only includes up to 16-inch diameter water mains, therefore, this is a special design. Design the block using the same general block configuration as the standard detail and as shown on Sketch "KK". Determine minimum dimensions of the concrete block needed to offset the vertical component of the thrust generated by the 30"-1/8 (45°) LVB. If the assumptions and limitations indicated in the "notes" on the standard detail are consistent with the particular special design, then generally the special design dimensions can be indicated in a note on the contract drawings referencing Standard Detail B/1.8 without providing a detail of the block on the plans. This is true for this case, therefore, the special design dimensions are determined as follows:

Determine soil design parameters.

A soil boring located at the proposed fitting supports the following soil design parameters:

Silty Sand, High Groundwater.

For soil boring requirements, see Part Three, Section 20, (Geotechnical and Corrosion Submittals).

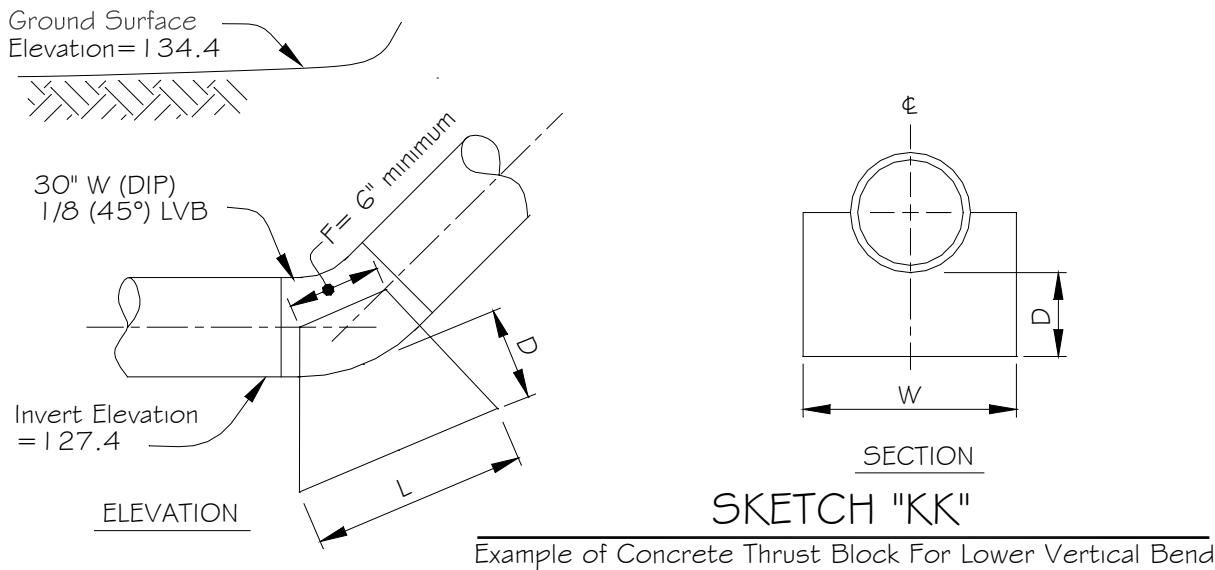

Determine design pressure:

$$\begin{aligned}
 P &= \text{design (total) pressure} \\
 &= ((\text{HHG} - \text{pipe invert}) \times 0.433) + \text{surge} = ((325 - 127.4) \times 0.433) + 80 \\
 P &= 165.63 \text{ lb/in}^2
 \end{aligned}$$

Determine thrust force

$$\begin{aligned}
 R_v &= \text{thrust (resultant force)} \\
 \text{Where: } P &= \text{design (total) pressure} & A &= \text{pipe cross sectional area} \\
 & & &= (\pi \times (\text{OD})^2) \div 4 \\
 \Theta &= 45^\circ \text{ (for a 1/8 HB)} & &= (3.1415927 \times (32.00)^2) \div 4 \\
 & & A &= 804.25 \text{ in}^2 \\
 R_v &= 2 P A \sin(\Theta \div 2) = 2 \times (165.63 \text{ lb/in}^2) \times (804.25 \text{ in}^2) \times \sin(45^\circ \div 2) \\
 R_v &= 101,952.93 \text{ lb}
 \end{aligned}$$

Using Sketch "KK", assume the following block dimensions:

$$L = 10 \text{ feet} \quad W = 7 \text{ feet} \quad D = 2 \text{ feet} \quad F = 6 \text{ inches (Minimum)}$$

Determine Area of Block:

$$\begin{aligned}
 A_b &= L \times W \\
 &= 10 \text{ feet} \times 7 \text{ feet} \\
 A_b &= 70 \text{ ft}^2
 \end{aligned}$$

Bearing Pressure - Check

$$\begin{aligned}
 P_b &= R_v \div A_b \\
 &= 101,952.93 \text{ lb} \div 70 \text{ ft}^2 \\
 P_b &= 1456 \text{ psf} < 2,000 \text{ psf} \quad \therefore \text{O.K.} \\
 &(\text{Allowable soil bearing pressure} = 2000 \text{ psf})
 \end{aligned}$$

Summary:

The assumed block size is adequate, provide this note on the drawings, either on the "Blocking Notes" or the "General Notes". "Block 30"-1/8 LVB at Station 2+00 with concrete according to Standard Detail B/1.8 using the following block dimensions: L = 10'-0", W = 7'-0", D = 2'-0" and F = 6" (minimum).



## h. Restrained Pipe Joints.

- 1) Concrete Thrust Blocks versus Restrained Pipe Joints. Always consider the use of concrete thrust blocks before the use of restrained pipe joints to resist the thrust forces acting on the pipe and fittings. However, there are some circumstances where restrained pipe joints may be the most practical method to prevent the separation of the pipe and fittings caused by the thrust forces. The use of restrained joint piping must be approved. Some common circumstances when the use of restrained joints may be appropriate are as follows:
  - a) There is not enough clearance between the proposed pipeline and nearby existing or proposed utilities or structures for a concrete thrust block. Clearance is not only the physical size of the block, but also the extent of the soil required to provide passive soil resistance for the block, see Passive Soil Pressure for Concrete Thrust Blocks, see this section.
  - b) Situation where many fittings are in close proximity.
  - c) Congested location, such as certain areas of the yard piping at a treatment plant where there are a large number of other pipelines in very close proximity, crossing each other, installed in common trenches at the same elevation or there is a very high probability that future pipes will be installed which would disturb the existing thrust blocks.
- 3) Design considerations.
  - a) In the Specifications various types of restrained joints are specified. Different types of restrained joints are manufactured for different ranges of pipe sizes and design internal pressures. Verify the pressure rating during the selection of the type of restrained joint and specify the appropriate type of restrained joint for the particular application.
  - b) Restrained joint systems. Resistance of thrust forces by the use of restrained joint pipe.
    - (1) Restrained joints only system. This method uses the friction between the soil and the specified length of restrained pipe to resist the thrust force. No passive soil resistance at the fitting and/or pipe shall be considered. The total friction force calculated shall be at least 1.5 times the full thrust force ( $P \times A$ ), except for restraining reducers where the design thrust force is  $P(A_1 - A_s)$  as defined in this section.
    - (2) No soil cohesion term should be used in evaluating the soil-pipe friction.
      - a) When using V-Bio encasement **divide the  $L_{\text{required}}$  (length of restrained joints) by 0.7 feet.**
    - (3) Use the following equation for determining the required restrained length. **No other methods will be approved.**
    - (4) **If not Soil Borings is available, use level of ground water at top of pipe.**





$$L_{\text{required}} = (F \times S_f) \div ((2W_e + W_p + W_w) \times \tan \delta)$$

Where:

- L = minimum length of pipe to be restrained  
(restrained length for each leg in the case of a bend)
- F = thrust force = P x A
- P = design pressure
- A = cross sectional area of pipe  
(using OD of pipe which equals the sealing diameter)
- S<sub>f</sub> = safety factor (1.5)
- W<sub>e</sub> = earth prism load (per foot length of pipe) \*
- W<sub>p</sub> = weight of pipe (per foot length of pipe) \*
- W<sub>w</sub> = weight of water in pipe (per foot length of pipe)
- δ = friction angle between dissimilar materials  
(from NAVFAC DM-7.2, Table 1, May 1982, Foundations and Earth Structures)

\* Use effective (submerged) weight for below groundwater condition.

If no soil borings information is available assume ground water is equal to top of pipe.

c) Length of Restrain Joint Pipe for 12-inch and Smaller Pipes.

(1) Use Table 27, and no calculations will be required.

**TABLE "27"**  
Restrain Joint Pipe Length.

Pipe Diameter	Length of Restrained Joints, with V-Bio Encasement	Length of Restrained Joints, with no V-Bio Encasement
4-inch	240 feet	170 feet
6-inch	340 feet	240 feet
8-inch	440 feet	305 feet
10-inch	523 feet	370 feet
12-inch	610 feet	430 feet

The lengths were computed based upon the formula given in this section for Restrained Joint Systems and are based upon the following assumptions:

weight of soil	= 120 pcf	total pressure	= 250 psi
minimum earth cover	= 4 feet	weight of water	= 62.4 pcf
interface friction angle (pipe/earth)	= 11°	safety factor	= 1.5
ground water at top of pipe.			

4) Restrained joint information to be included on the drawings.

- a) Indicate on the profile the limits of the restrained joint length including the stations (to and from).
- b) Also provide a similar note in the Blocking Notes or General Notes. Typical note, "Restrained 12"W from the 12" plug/cap at station 0+00 to station 2+00".



**i. Design Example for Determining Required Length of Restrained Pipe.**

Determine the length of restrained pipe necessary to restrain a 12" plug or cap on a 12" DIP class 54 water pipeline.

Design parameters.

No fittings or valves located in the proposed restrained length.

Average depth of cover to the top of the pipe is 4 feet.

12" Plug invert elevation = 212.00 ft.

12" Plug at Station 3+61

Pipe outside diameter (OD) = 13.2 inches (ANSI/AWWA C150/A21.50)

Wall thickness of 12" DIP Class 54 = 0.43 inches. (ANSI/AWWA C150/A21.5, Table 50.5)

Pipe inside diameter (ID) = OD - (2 × wall thickness) = 12.34 inches.

HHG (High Hydraulic Grade) = 385 feet Surge pressure = 100 lb/in<sup>2</sup>

For obtaining HHG and surge pressure, see Part One, Section 5, (Total Internal and Transient Pressures).

Determine soil design parameters.

A nearby soil boring supports the following soil design parameters:

Fine sandy silt, No Groundwater

$\gamma$  = soil unit weight = 120 lb/ft<sup>3</sup>  $\phi$  = soil friction angle = 25°

$\delta$  = pipe-soil friction angle = 11°

Determine design pressure:

P = design pressure

= (HHG - pipe invert elevation) 0.433 + surge = (385 - 212.00) × 0.433 + 100

P = 174.90 lb/in<sup>2</sup>

Determine thrust force:

F = thrust = P (design (total) pressure) × A (pipe cross sectional area)

= P × (( $\pi$  × OD<sup>2</sup>) ÷ 4)

= P × ((3.1415927 × (13.2)<sup>2</sup>) ÷ 4)

= 174.90 lb/in<sup>2</sup> × 136.84 in<sup>2</sup>

F = 23,933.32 lb

Determine weight of the earth:

W<sub>e</sub> = weight of the earth

= OD (in feet) ×  $\gamma$  × depth to top of pipe

= (13.2 in ÷ 12) × 120 lb/ft<sup>3</sup> × 4 ft

W<sub>e</sub> = 528 lb/ft

Determine weight of pipe:

W<sub>p</sub> = weight of the pipe

W<sub>p</sub> = 52.80 lb/ft (ANSI/AWWA C151/A21.51, table 51.4, for push-on pipe. If using proprietary restrained joint pipe, obtain the pipe weight from the pipe manufacturer's information.)



Determine weight of water:

$$\begin{aligned}
 W_w &= \text{weight of the water} \\
 &= \text{inside area of pipe (change to ft}^3\text{)} \times \text{unit weight of water} \\
 &= ((ID^2 \times \pi \div 4) \div 144) \times 62.4 \text{ lb/ft}^3 \\
 &= ((12.34 \text{ in})^2 \times 3.1415927 \div 4) \div 144) \times 62.4 \text{ lb/ft}^3 \\
 &= (119.60 \text{ in}^2 \div 144) \times 62.4 \text{ lb/ft}^3 \\
 W_w &= 51.83 \text{ lb/ft}
 \end{aligned}$$

Determine the minimum restrained length required:

$$\begin{aligned}
 L_{\text{required}} &= (F \times S_f) \div ((2W_e + W_p + W_w) \times \tan \delta) \\
 &= (23,933.32 \text{ lb} \times 1.5) \div (((2 \times 528 \text{ lb/ft}) + 40.2 \text{ lb/ft} + 51.83 \text{ lb/ft}) \times \tan 11^\circ) \\
 &= 35,899.98 \div ((1056 + 52.80 + 51.83) \times \tan 11^\circ) \\
 &= 35,899.98 \div (1160.60 \times \tan 11^\circ) \\
 &= 35,899.98 \div 220.16 \\
 L_{\text{required}} &= 163.07 \text{ feet}
 \end{aligned}$$

Summary:

Indicate on the drawings in the "Blocking Notes" or the General Notes the following: "Restrain 12" W from the 12" Plug/Cap at station 3+61 to station 2+00". Also, show the limits of the restrained length on the water main profile, indicating stations.

See Sketch "LL" for Retrained Joint Plugs or Caps and see Sketch "LL A" for Retrained Joint Bends and Tees.

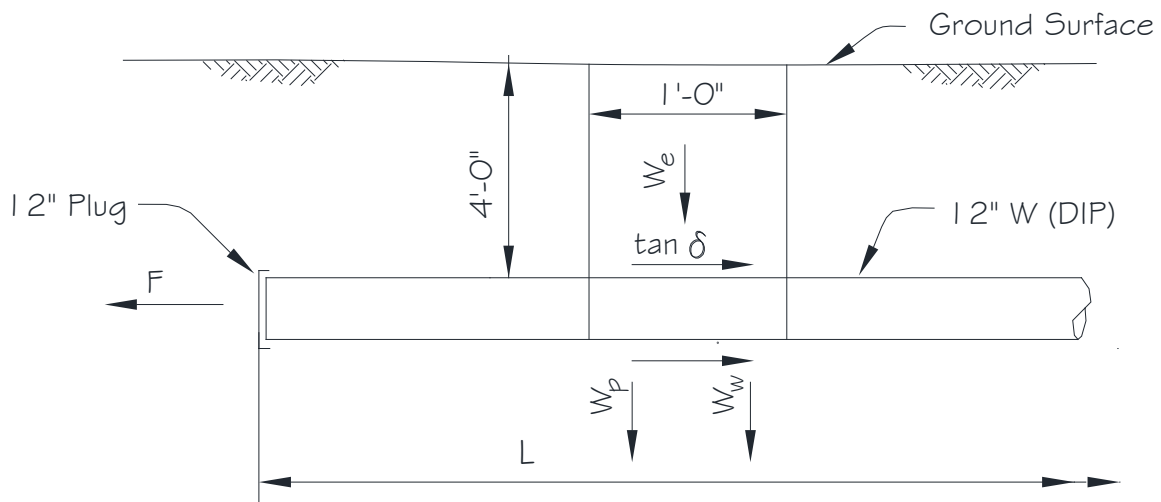

EXAMPLE FOR REDUCERS

SKETCH "LL"

Example of Retrained Joint System



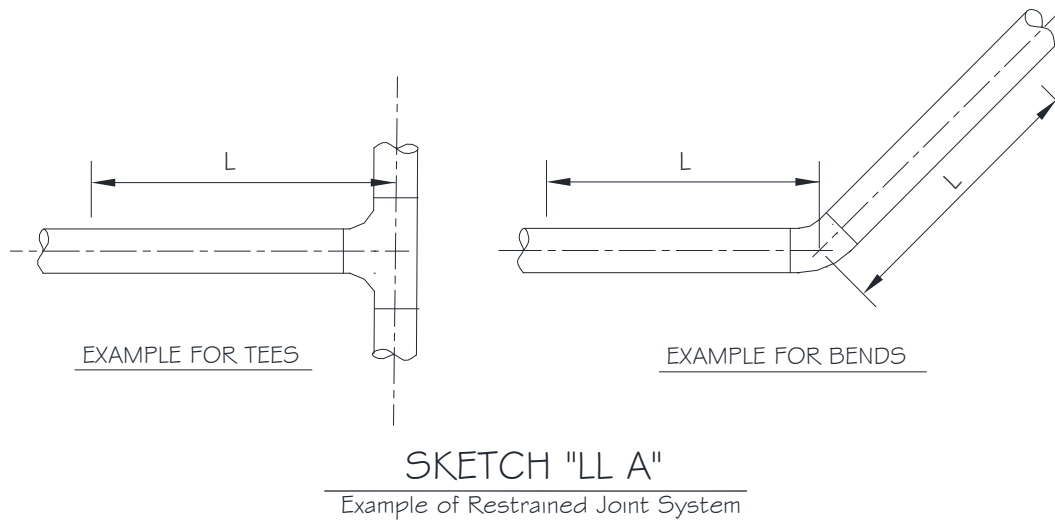

**j. Thrust Blocks for Quick Connections to Existing Pipelines.**

1) Pre-poured thrust block.

- a) Generally used at a horizontal bend where a new pipe will tie into an existing pipe that has a limited shut down time for making the connection. Another use of the block is for a new tee when a new pipe is branched off from an existing pipe, the connection time is limited, and a TS&V cannot be used.
- b) The block consists of a pre-poured rectangular reinforced concrete block, a steel member between the bend or tee and the pre-poured block which is placed during the limited shutdown to transfer the thrust to the pre-poured block, and a final concrete block encasing the steel member poured after the main is pressurized. See Standard Detail B/3.2 for water pipelines 24" and smaller. Special Design is required for larger than 24-inch and all 90° (1/4) bends. If the total pressure (operating plus surge) is greater than 250 psi a special design is required.
- c) The special design consists of an initial concrete block, bearing rack assembly and final concrete. For all pipe sizes the initial concrete block consists of a rectangular pre-poured block. Determine the size of the block using one of the methods described in this section under Concrete Thrust Blocks, herein, for horizontal bends or tees. Indicate the special design dimensions and steel reinforcement requirements on the drawings. Locate the pre-poured block, such that the existing pipe can be removed and the new bend or tee can be installed without great difficulty.

**k. Welded-on Thrust Ring Blocks for New Pipe.**

- 1) Generally used where the thrust force in the direction of the pipe axis requires restraint. However, due to the cost and the lead time required to order the pipe with a welded-on steel ring from the pipe manufacturer, a thrust ring block should only be used after the use of standard design blocking, as described in this section, has been ruled out. The most common



circumstances where this block is used are as follows:

- a) The required length of restrained joint pipe to resist the axial thrust is not available.
- b) Analysis indicates that it will be more economical to use a short section of restrained joint pipe combined with a thrust ring block rather than to use the full required length of restrained joint pipe.
- c) For a plug/cap at the end of the new pipeline where a future connection will be made. This block is used in lieu of a standard design block for caps or plugs as described in Concrete Thrust Blocks, in this section, to easily facilitate the future connection because the removal of the block is not required. It also minimizes service disruption during the future connection. This type of application should generally be considered for large diameter pipelines and for pipelines where the location of a valve is near the collar, which would also allow the collar to be used as a permanent restraint for the valve.

## 2) Design.

- a) The thrust ring block consists of a steel ring factory welded to a new pipe and then cast into a reinforced concrete collar block. The thickness and the final outside diameter of the steel ring welded to the pipe are generally determined by the pipe manufacturer, see Thrust Rings below, for the design requirements and the information to be shown on the drawings.
- b) Pipe sizes 18-inch and smaller, the size and details for welded-on thrust ring blocks for pipe sizes 18-inch and smaller can be referred to Standard Detail B/3.3.
- c) Pipe sizes larger than 18-inch, determine the size of the reinforced concrete collar. Two sides of the block should extend at least one (1) foot beyond the sides of the trench into the undisturbed soil. Provide a special detail indicating the special design block dimensions, steel reinforcement requirements, etc. on the drawings.

## 3) Thrust rings.

- a) Thrust rings are steel or iron rings welded onto the barrel of new DIP for the purpose of restraining thrusts. These rings are factory designed and welded by the pipe manufacturer or their fabricator.
- b) Thrust rings are not covered by the AWWA standards; each pipe manufacturer has their own design. When specifying the rings on the drawings, care must be taken to design and detail the thrust transfer mechanism from the ring to the thrust restraint and provide correct and sufficient information to facilitate the contractor when ordering and installing the thrust rings.
- c) In lieu of other rational designs, the following design considerations and methodology may be followed subject to each project's special requirements:
  - (1) Thrust rings can be welded onto new pipe barrels only, not cast fittings or cast specials. Manufacturers' seep rings/collars, which are designed to prevent water penetration through a wall, typically called wall pipe or fittings, shall not be mistaken for thrust rings.
  - (2) Some manufacturers have directional thrust rings. The drawings should clearly depict the direction/directions of the thrust. When thrust can act in either direction, design only bi-



- directional thrust rings and design concrete member (collar block or wall) accordingly.
- (3) If the thrust rings will be encased in concrete, clearly indicate the bearing face or faces and their location within the concrete. Thrust rings can be up to three (3") inches thick.
  - (4) The following information will need to appear on the drawings either by notes or in a table:
    - (a) Thrust ring shall be designed for a thrust of \_\_\_ kips, acting in (indicate one or both) directions. (Also show an arrow indicating the direction of the thrust on the detail.)
    - (b) The area of the thrust ring shall be proportioned such that the bearing stress on the concrete does not exceed one thousand (1000) psi.
    - (c) Locate the thrust ring two (2) feet minimum from the end of the pipe.
  - (5) Thrust rings are designed by the manufacturer to bear on a uniform surface such as concrete. Point bearing such as provided by beam flanges or channel flanges on two or four sides should be avoided or contact the manufacturer for any special design requirements.
  - (6) Design considerations when transferring the thrust ring load to a concrete wall or concrete thrust collar block:
    - (a) "d" for punching shear - from the thrust face of the ring to the centroid of the tension reinforcement.
    - (b) "d" for diagonal shear and for moment - from the compression face of the concrete to the centroid of the tensile reinforcement.
    - (c) Face of the support for diagonal shear and moment - tangent to the pipe surface.
    - (d) Reinforcing bars interrupted by the pipe penetration - accounted for by placing additional reinforcing around the pipe penetration.

#### **I. Restraining Reducers.**

- 1) Restrain all reducers, using either restrained joints or concrete thrust blocks.
  - 2) **For restrained joints: for reducers:**
    - a) Restrain the required length of the larger diameter pipe; refer to Restrained Pipe Joints in this section, for the method of determining the required restrained pipe length. The design thrust force (F) used for the design shall be  $F = P(A_1 - A_s)$  as indicated under Design Thrust Force (F) for fittings, in this section.
- (1) **For example of calculation for retraining reducers, see Design Example for Determining Required Length of Restrained Pipe, in this section. Charge  $F = P \times A$  to  $F = P (A_1 - A_s)$ . No other methods will be approved.**



3) Design considerations.

- a) In the Specifications various types of restrained joints are specified. Different types of restrained joints are manufactured for different ranges of pipe sizes and design internal pressures. Verify the pressure rating during the selection of the type of restrained joint and specify the appropriate type of restrained joint for the particular application.
- b) Restrained joint systems. Resistance of thrust forces by the use of restrained joint pipe.
- c) Restrained joints only system. This method uses the friction between the soil and the specified length of restrained pipe to resist the thrust force. No passive soil resistance at the fitting and/or pipe shall be considered. The total friction force calculated shall be at least 1.5 times the full thrust force  $P(A_1 - A_s)$ .
- d) No soil cohesion term should be used in evaluating the soil-pipe friction.
- e) When using **V-Bio** encasement **divide the  $L_{\text{required}}$  (length of restrained joints) by 0.7 feet.**
- f) **If not Soil Borings is available, use level of ground water at top of pipe.**

**See Sketch "PP A" for Retrained Joint for Reducers.**

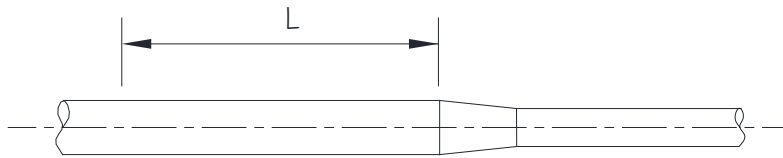

EXAMPLE FOR REDUCERS

### SKETCH "PP A"

Example of Restrained Joint System



g) Length of Restrain Joint Pipe for 12-inch and Smaller Pipes with reducers.

(1) Use Table 28, and no calculations is will be required.

**TABLE "28"**  
Restrain Joint Pipe Length for Reducers

Reducer Size	Length of Restrained Joints, with V-Bio Encasement	Length of Restrained Joints, with no V-Bio Encasement
4-inch x 3-inch	80 feet	55 feet
6-inch x 4-inch	175 feet	125 feet
8-inch x 4-inch	390 feet	275 feet
8-inch x 6-inch	180 feet	130 feet
10-inch x 4-inch	425 feet	295 feet
10-inch x 6-inch	315 feet	220 feet
10-inch x 8-inch	175 feet	370 feet
12-inch x 4-inch	525-feet	370 feet
12-inch x 6-inch	440 feet	310 feet
12-inch x 8-inch	320 feet	225 feet
12-inch x 10-inch	180 feet	125 feet

The lengths were computed based upon the formula given in this section for Restrained Joint Systems and are based upon the following assumptions:

weight of soil	= 120 pcf	total pressure	= 250 psi
minimum earth cover	= 4 feet	weight of water	= 62.4 pcf
interface friction angle (pipe/earth)	= 11°	safety factor	= 1.5
ground water at top of pipe.			

Summary:

Indicate on the drawings in the "Blocking Notes" or the General Notes the following: "Restrain 12"x 10" Reducer from station 3+80 to station 2+00". Also, show the limits of the restrained length on the water main profile, indicating stations.

- 4) Methods for reducer restraint. Use the most cost effective alternative for restraining the reducer and submit calculations. The following are several methods commonly used, with the first method being preferred.
- a) Cast a reinforced concrete thrust collar block directly around the reducer, see Sketch "MM". Determine size of the concrete collar block and design thrust force, with the method described in this section for reducers in Concrete Thrust Blocks.





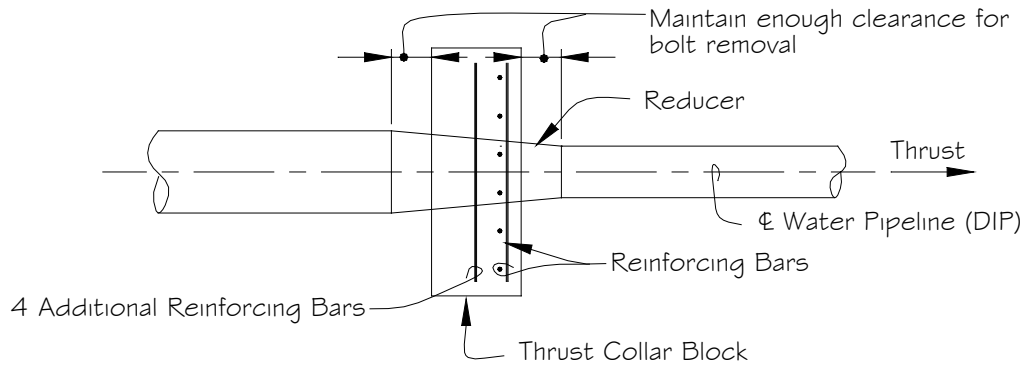

### SKETCH "MM"

Thrust Block Cast Directly Around Reducer

- b) Cast a welded-on thrust ring block around the larger diameter pipe and restrain all joints between the block and the reducer, see **Sketch "NN"**. Determine size of the collar block and the design thrust force, with the method described herein for reducers in Special Design Concrete Thrust Blocks.

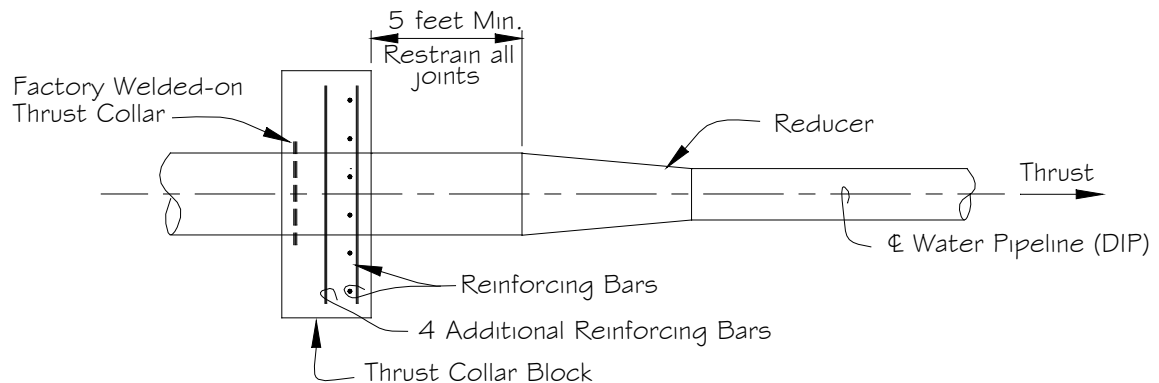

### SKETCH "NN"

Welded-on Thrust Ring Block to Restrain Reducer (Large End)

- c) Cast a welded-on thrust ring block around the smaller diameter pipe and fully home all the pipe joints between the block and the reducer, see Sketch "OO". Determine size of the collar block, using the larger pipe diameter. The design thrust force, with the method described in this section for reducers in Special Design Concrete Thrust Blocks.



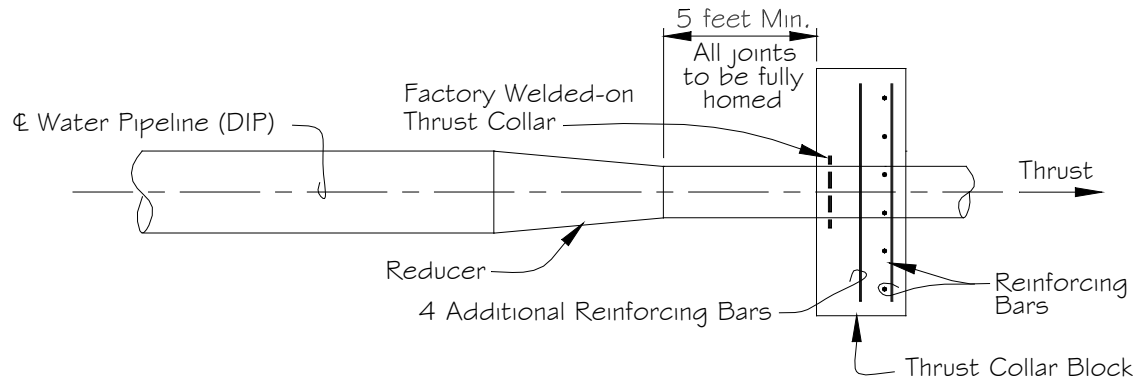

SKETCH "OO"

Welded-on Thrust Ring Block to Restrain Reducer (Small End)

- h) Restrain the required length of the larger diameter pipe, refer to Restrained Pipe Joints in this section, for the method of determining the required restrained pipe length. The design thrust force (F) used for the design shall be  $F = P(A_1 - A_s)$  as indicated under Design Thrust Force (F) for fittings, in this section.

- i) When restraining a reducer to a tee, see sketch "P-P".

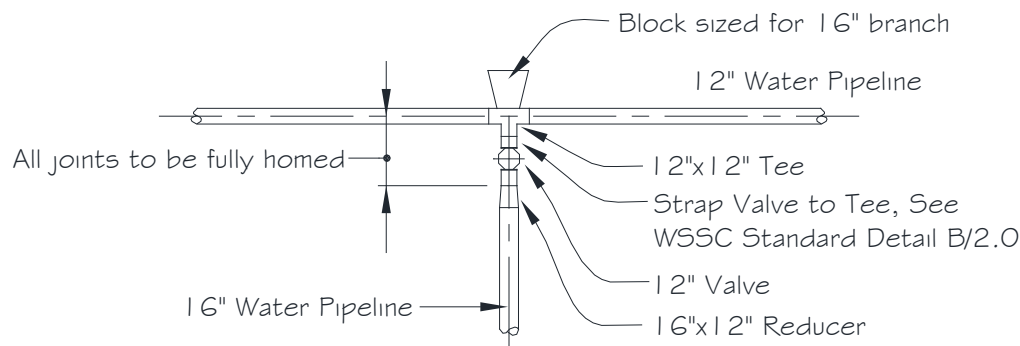

SKETCH "PP"

Blocking A Reducer When Reducing Down Into A Tee

### m. Restraining Valves.

#### 1) Direct buried valves 14-inch and smaller.

- a) If the direct buried valve is located near a tee, restrain all joints between the valve and the tee. Provide a concrete block behind the tee.
- b) If the direct buried valve is located on pipelines to be extended on another contract or in the future, restrain all joints see Restrained Pipe Joints, in this section.

- 2) Valves 16-inch and larger. Install within vaults and restrain. There are two general methods of restraining large valves. One method is to use a thrust vault, see Sketch "QQ", which is a vault that takes the thrust generated from a closed valve and transfers it to the vault walls which in turn transfers it to the soil. The other method is to use concrete thrust collar blocks on each side of



the valve, located away from the valve vault, see Sketch "RR".

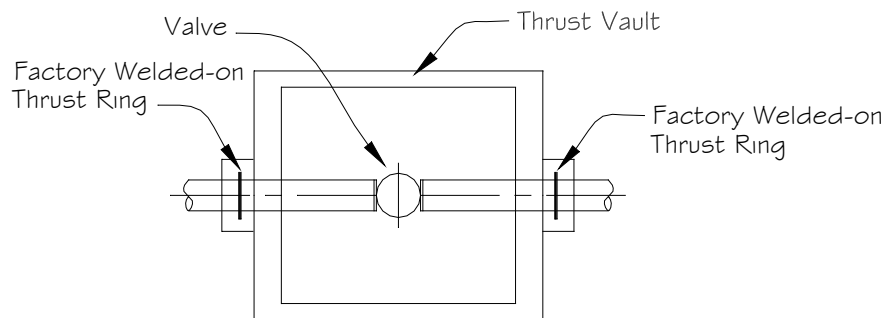
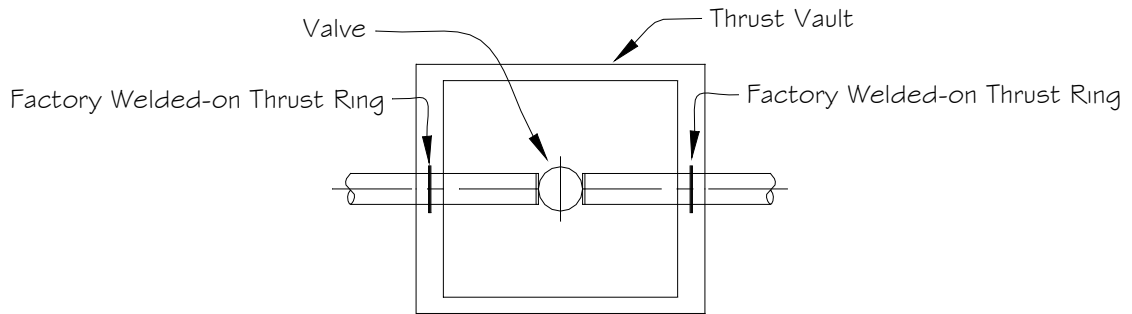

SKETCH "QQ"

Schematic Examples of Thrust Vaults For 16" and Larger Valves

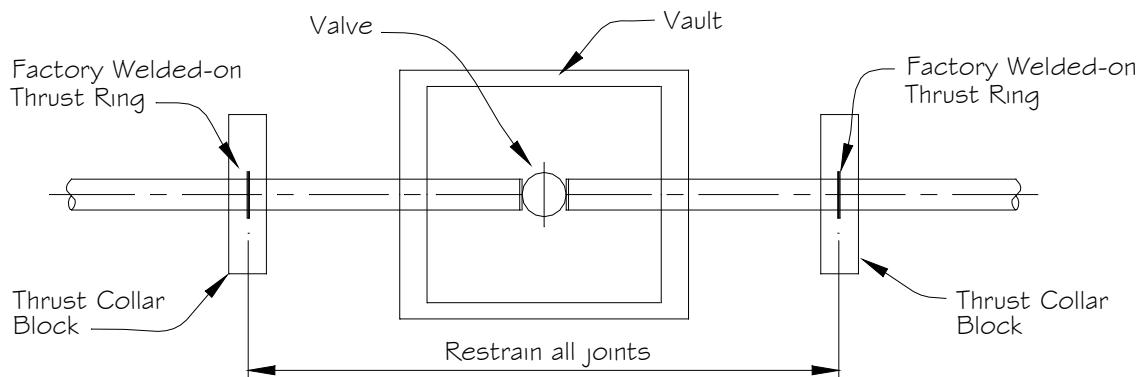

SKETCH "RR"

Valves 16" and Larger Restrained with Thrust Collar Blocking

- a) Determine size of the thrust vault, in accordance with passive earth pressure theory with consideration of the frictional forces acting along the sides as well as on the base of the vault. For structural design requirements, see Part Three, Section 16, (Design of Pipeline Structures).
- b) When restraining a valve with concrete thrust collars, locate the collars so the vault is outside of the passive soil pressure zone of the collars, see Passive Soil Pressure for Concrete Thrust Blocks, in this section.



- 3) Line Stops. Temporary method for shut down of existing water pipelines. The line stop must be blocked to prevent the line stop from moving during closed condition. Submit method and special designs, see requirements under Special Design for Concrete Thrust Blocks in this section.

**n. Unbalanced Thrust at Connections to Existing Water Pipelines.**

- 1) Take into account the potential unbalanced thrusts due to different pipe material and/or pipe deflections when making connections to existing or dissimilar pipelines. Provide pipe/joints restraints as necessary to balance these forces. This is especially true for large diameter water pipelines, where the thrust can be large.
- 2) Potential unbalanced thrusts - different pipe materials.
- a) Check for unbalanced thrusts due to different pipe materials and different sealing diameters. The thrust generated is similar to that which occurs at reducers.
- b) The sealing diameter is the internal diameter of the gasket at the bell joint, where the internal water pressure comes in contact. For DIP use the pipe OD and PCCP use the joint diameter at the gasket, see Table "29". For other pipe materials, verify the sealing diameter dimension, with the pipe manufacturer or the reference standards for the pipe.

**TABLE "29"**  
DIP and PCCP Sealing Diameters

Pipe Sizes (inches)	Sealing Diameters (inches)		
	Ductile Iron Pipe (DIP) *	Lockjoint Prestressed Concrete Cylinder Pipe (PCCP) **	
		SP-5	SP-12
16	17.40	18.50	--
20	21.60	23.00	--
24	25.80	27.50	27.00
30	32.00	34.25	33.00
36	38.30	41.00	39.00
42	44.50	47.25	45.00
48	50.80	54.00	51.25
54	57.56	--	57.75
60	61.61	--	63.88

\* from AWWA C151

\*\* from Lockjoint Pipe Catalog

**Example - Sealing diameters of different pipe material.**

Existing 48" PCCP, SP-5 Water Main, Sealing diameter = 54.00 inches, see Table "29"  
 Proposed 48" DIP, Water Main, Sealing diameter = 50.80 inches, see Table "29"  
 Design Pressure: Working pressure = 124 psi Surge pressure = 70 psi

See Sketch "SS".



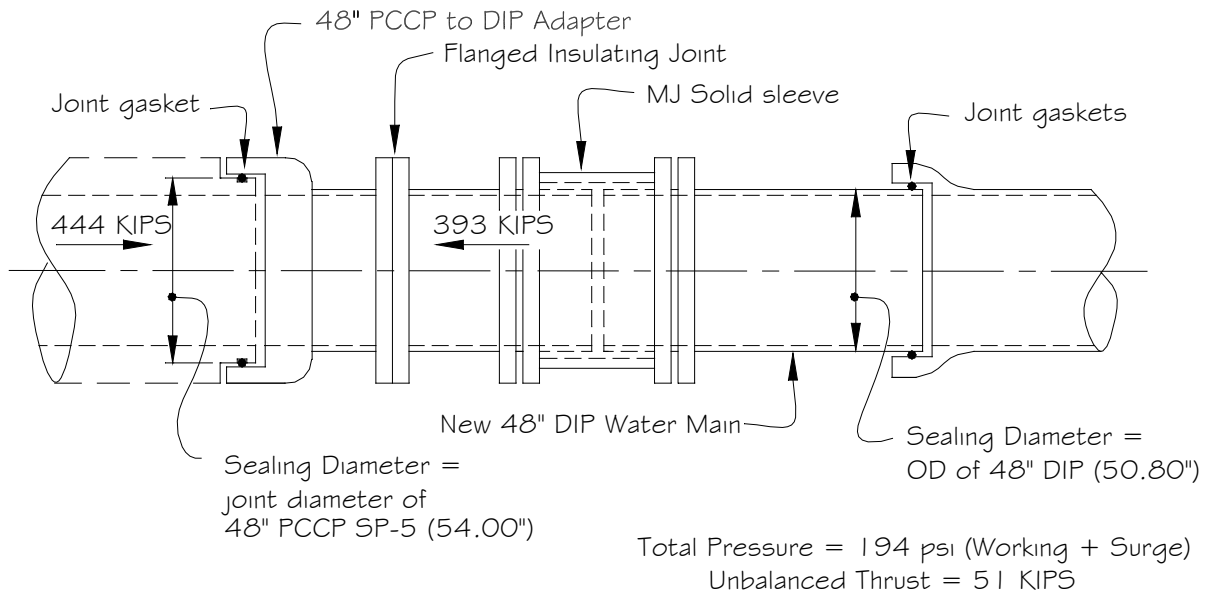

### SKETCH "SS"

Connection PCCP to DIP Showing Unbalanced Thrusts

Determine the unbalanced thrust at the connection to the existing 48" PCCP water pipeline:

$$P = \text{design pressure} = \text{operating} + \text{surge}$$

$$= 124 + 70$$

$$P = 194.00 \text{ lb/in}^2$$

$$A_{\text{DIP}} = \text{pipe joint cross sectional area (sealing diameter)}$$

$$= \pi(\text{O.D.})^2/4$$

$$= \pi(50.80)^2/4, \text{ See Table 29}$$

$$A_{\text{DIP}} = 2026.89 \text{ in}^2$$

$$T_{\text{DIP}} = \text{Thrust for 48" DIP}$$

$$= A_{\text{DIP}} \times P$$

$$= (2026.89 \text{ in}^2)(194.00 \text{ lb/in}^2)$$

$$= 393,216.66$$

$$T_{\text{DIP}} = 393 \text{ KIPS}$$

$$A_{\text{PCCP}} = \text{pipe joint cross sectional area (sealing diameter)}$$

$$= \pi(\text{O.D.})^2/4$$

$$= \pi(54.00)^2/4, \text{ See Table 29}$$

$$A_{\text{PCCP}} = 2290.22 \text{ in}^2$$

$$T_{\text{PCCP}} = \text{Thrust for 48" PCCP}$$

$$= A_{\text{PCCP}} \times P$$

$$= (2290.22 \text{ in}^2)(194.00 \text{ lb/in}^2)$$

$$= 444,302.68$$

$$T_{\text{PCCP}} = 444 \text{ KIPS}$$

$$F = \text{Unbalanced Thrust} = P(A_{\text{PCCP}} - A_{\text{DIP}})$$

$$= (194.00 \text{ lb/in}^2)(2290.22 \text{ in}^2 - 2026.89 \text{ in}^2)$$

$$= (194.00 \text{ lb/in}^2)(263.33 \text{ in}^2)$$

$$= 51,086.02 \text{ lb}$$

$$F = 51 \text{ KIPS, Restrain or block the unbalanced thrust, see How to Restrain Reducers and Thrust Blocks for Quick Connections to Existing Pipelines, in this section.}$$



3) Potential Unbalanced Thrusts - Alignment deflections.

- a) Check alignment deflections for unbalanced thrust due to joint deflections, deflections in connecting pieces (PCCP bevel adapter), etc. The thrust generated is similar to that which occurs at bends. If possible, align the connection with no vertical/horizontal deflections.
- b) If the alignment has vertical/horizontal deflections, also account for the thrust restraints due to the alignment, see the example below.

**Example** - Unbalanced thrust due to an alignment deflection at the connection to existing pipelines:

Existing 48" PCCP, SP-5 Water Main,

Proposed 48" DIP, Water Main

Design Pressure: Working pressure = 124 psi Surge pressure = 70 psi

Connection requires Full Bevel Adapter (4°-15' deflection)

Determine the unbalanced thrust at the connection to the existing 48" PCCP water pipelines:

$$\begin{aligned}
 P &= \text{design pressure} & A_{\text{PCCP}} &= \text{pipe joint (sealing diameter) cross sectional area} \\
 &= \text{operating} + \text{surge} & &= \pi(\text{O.D.})^2/4 \\
 &= 124 + 70 & &= \pi (54.00)^2/4, \text{ see Table 29} \\
 P &= 194.00 \text{ lb/in}^2 & A_{\text{PCCP}} &= 290.22 \text{ in}^2
 \end{aligned}$$

$$\begin{aligned}
 R &= \text{resultant thrust at the bevel adapter} \\
 &= 2 P A \sin (\Theta \div 2) = 2 P A_{\text{PCCP}} \sin (4^\circ-15' \div 2) \\
 &= 2 (194.00 \text{ lb/in}^2) (290.22 \text{ in}^2) (\sin 2^\circ-07'-30") \\
 &= (388.00 \text{ lb/in}^2) (290.22 \text{ in}^2) (0.0370797)
 \end{aligned}$$

$$R = 32,949.26 \text{ lb. The resultant thrust at the adapter may require concrete blocking, see Special Design Concrete Thrust Blocks, in this section.}$$

Also, take in consideration the unbalanced forces between the different pipe materials, see Example for "Sealing diameters of different pipe material", in this section.

**o. Passive Soil Pressure for Concrete Thrust Blocks.**

- 1) The function of concrete thrust blocks depends on the passive soil resistance. Sketch "TT" illustrates the approximate zone of influence and provides the equation to calculate the distance required behind a thrust block necessary for passive soil resistance. When determining if there is adequate passive soil resistance available for a proposed thrust block, consider the following items:
  - a) How likely are future excavations within the zone of influence?
  - b) Are there any utilities or structures within the proposed zone of influence for the block? Will the other utilities or structures be able to be excavated without the thrust block becoming unstable?
  - c) The passive earth pressures and active earth pressures shall not influence one another.
  - d) Take into account the slope of the ground in the calculations if it is ten (10°) degrees or more from the horizontal.



- e) Are there any abnormal soil characteristics which may affect the passive resistance?

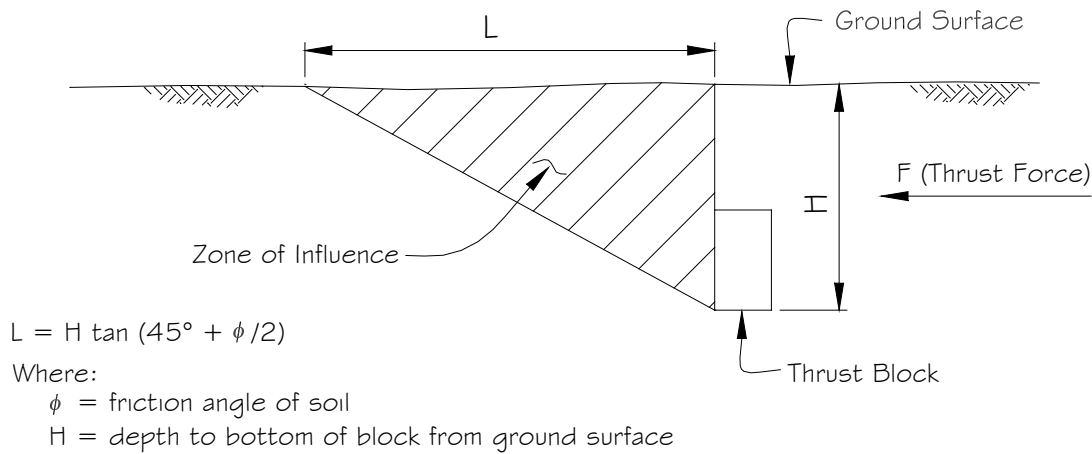

### SKETCH "TT"

Zone of Influence for Passive Soil Resistance

#### p. Blocking Notes on the Drawings.

- 1) This section discusses where blocking notes should appear on the drawings and what information they should contain.
  - a) Location of Blocking Notes on the drawings.
    - (1) The notes should generally be placed on the first sheet, under "Blocking Notes". If these notes are not on the first sheet, there should be a note in the General Notes indicating which sheet they are on.
    - (2) Reference in the Blocking Notes, all standard and/or special details and restrained joints that are to be used for thrust restraint under the design contract.

#### Examples - Common Blocking Notes:

1. Strap fire hydrants to main, see Standard Detail B/2.1. Do not block fire hydrants or fire hydrant tees.
2. Block all horizontal bends with concrete; see Standard Detail B/1.0.
3. Block the 24"-1/8 HB at station 2+43 with concrete, see Standard Detail B/1.0, except use the following dimensions:  $T = 5'-0"$ ,  $H = 10'-0"$ ,  $F = 1'-6"$ , and  $L = 12'-0"$ .
4. Block 12"-1/8 HB at stations 0+00 and 3+87 at connections to existing 12" W according to Standard Detail B/3.2, see sheet 3 of 5 for details of the initial block.
5. Restrain all joints on 12" W from station 2+45 to station 3+25.



## 28. Corrosion Control.

### a. Abbreviation.

NACE National Association of Corrosion Engineers (NACE International)

### b. General.

- 1) This section includes the specific corrosion control design requirements for buried ductile iron pipe and general guidance on the type of corrosion control to be provided for other ferrous metal pipelines. The topics addressed include when corrosion control is necessary, design and submittal procedures, and site evaluation criteria for selecting the type of corrosion control required.
- 2) Future/proposed extension of WMATA Metrorail lines, Maryland Transit Administration (MTA) Rail Lines, Maryland Transit Administration (MTA) Traction Power Station Substation (TPSS) and AMTRAK (National Rail Passenger Corporation rail lines powered by electricity see Table “32” (Stray Current Analysis) for Severe Exposure.
- 3) If WMATA Metrorail lines, Maryland Transit Administration (MTA) Rail Lines, Maryland Transit Administration (MTA) Traction Power Station Substation (TPSS) and AMTRAK (National Rail Passenger Corporation rail lines powered by electricity is designing a new extension near WSSC existing pipeline, see Part One, Section 10, Relocating Water Pipeline or Part Two, Section 7, Relocating Sewer Pipeline and Table “32” (Stray Current Analysis) for Severe Exposure.
- 3) All ferrous metal pipelines, particularly ductile iron and steel are to be evaluated to determine what corrosion control measures will be required. The specific pipe sizes, materials, and conditions which are to be evaluated for corrosion control include:
  - a) All sizes of Ductile Iron Pipe (DIP). Corrosion control is required for all buried DIP as follows:
    - (1) DIP smaller than 16-inch. Generally, V-Bio polyethylene encasement and Zinc Coated DIP will be used on all pipes in this size range and can be expected to provide adequate corrosion control except when stray currents are encountered or anticipated. Another consideration will be soil condition analysis. Follow the procedures and guidelines in this section to evaluate the pipeline for sources of stray currents. Determine the type of material of the existing pipe that is being connected to in order that protection can be provided against galvanic corrosion between dissimilar pipe metals. Also, determine if the existing pipe has some form of corrosion control. Based on stray current and existing pipe analyses, protection beyond that provided by V-Bio polyethylene encasement may be required, such as coating DIP or selecting coated steel pipe or non-metallic pipe material.
    - (2) 16-inch and larger DIP. Ductile iron water pipelines and sewers pipelines, 16-inch and larger at a minimum will require Zinc Coated DIP with V-Bio polyethylene encasement. Complete evaluation is required to determine the corrosion control requirements as outlined in this section.





- b) All sizes of exposed (non-buried) DIP. Provide paint or coating material to protect the pipe from the environmental effects to which it is exposed such as road salts, submersion, etc. The analysis and design guidelines for exposed DIP are not included in this section.
- c) All sizes of steel pipe. Corrosion control is required for all exposed and buried steel pipe. This includes pipe coatings, cathodic protection, electrical isolation and a cathodic protection monitoring system. The analysis and design guidelines for steel pipe are not included in this section.
- 4) Corrosion design qualifications. A Corrosion Engineer, a NACE Certified Senior Corrosion Technologist or a NACE Certified CP or Corrosion Specialist is **required to oversee all work required under this section of the Pipeline Design Manual, except for Corrosion Survey Checklist.**
- 5) Test station numbering.
  - a) If the design requires corrosion monitoring test stations, WSSC will provide the test station numbering. **Submit a request to WSSC Technical Services Group for test stations numbers.**
  - b) Existing test stations are numbered and recorded on **test station cards** on file at WSSC. . Show on drawings the location and number of the existing test stations.
- 6) **When a corrosion control design is required, the anode groundbed is to have a minimum horizontal separation from existing PCCP pipelines is six hundred (600) feet and three hundred (300) feet if approved by WSSC Technical Services Group.**

**c. Corrosion Design Procedure and Submittal Requirements.**

- 1) The corrosion control design procedure consists of up to three (3) submittal stages. A detailed description of the submittal requirements is included below. For convenience, the submittals for stages one and two are standard forms, a checklist and a documentation form contained at the end of this section. The third submittal consists of the corrosion design drawings and specifications, which are required, only if more stringent corrosion control measures prove to be necessary. A summary of the three specific submittal stages is as follows:
  - a) First submittal. For all ductile iron pipe sizes, submit the completed Corrosion Survey Checklist including preliminary plans showing the pipeline alignment and proposed soil boring locations as required in Appendix "E" (Subsurface Investigation Requirements for Water and Sewer Design and Construction). Detailed instructions for completing the Checklist are included at the end of this section. Perform the Existing Pipe Analysis as indicated in this section and include the results from Chart "D" on the Checklist in the space provided.
- 7) Second submittal.
  - (1) DIP smaller than 16-inch. If there are no sources of stray currents or any additional corrosion considerations from the checklist, then submit plans with corrosion control provisions if connecting to existing pipe according to Chart "D". If there are stray current sources complete the Stray Current Analysis and submit the results along with the completed Corrosion Documentation Form "B".



- (2) DIP 16-inch and larger. Perform the Stray Current Analysis and Soil Condition Analysis and submit the results along with the completed Corrosion Documentation Form "B", including the recommended corrosion control measures.
- 8) Third submittal. DIP 16-inch and larger and DIP smaller than 16-inch with stray current submit plans and specifications, including the corrosion control design, if required.

**d. Soil Condition Analysis.**

- 1) A Soil Condition Analysis is required for all 16-inch and larger water pipelines.
- 2) A Soil Condition Analysis is required for pipelines less than 16-inch if the proposed project crosses or is adjacent to areas known to have potentially corrosive soil conditions such as farms, golf courses or other areas that receive significant landscaping treatment that create a significant difference in soil chemistry as compared to the native soil.
- 3) Obtain soil samples along the alignment in accordance with Appendix "E" (Subsurface Investigation Requirements for Water and Sewer Design and Construction). Perform laboratory or field tests (in situ, where appropriate) for pH, chloride content, redox potential, soil description, and soil resistivity on soil samples taken at the pipeline depth. Intervals of the soil samples should not exceed one thousand (1000) feet, unless the pipeline alignment is less than two thousand (2000) feet in length, then the intervals should not exceed seven hundred (700) feet. A minimum of two (2) soil samples is required for each pipeline alignment.
- 4) Consideration must also be given to the possible exposure to roadway deicing salt. If the pipeline is located next/parallel to and below the bottom of a roadway ditch, follow the recommendations in Chart "D", under Stray Current Analysis, Moderate Exposure for the corrosion control requirements.
- 5) Decision Process.
  - (1) Obtain laboratory or field results from soil sample tests. Using the Analysis Type and Analysis Range columns in Table "30" determine points that will apply to each Analysis Type and total them to get the "Overall Corrosivity Rating" from Table "31" for the condition of the pipeline trench.
  - (2) For determination of the corrosion control requirements, see Chart "C".



**TABLE "30"**  
Soil Condition Analysis

ANALYSIS TYPE	ANALYSIS RANGE	POINTS	ANALYSIS TYPE	ANALYSIS RANGE	POINTS
PH	0 – 2	5	Soil Description	Clay (Blue-Gray)	10
	2 – 4	3		Clay/Stone	5
	4 – 8.5	0		Clay	3
	> 8.5	3		Silt	2
> 1000 ppm	10	Clean Sand		0	
Chloride Content	500 – 1000 ppm	6	---	--	
	200 – 500 ppm	4	< 1,000 ohm-cm	10	
	50 – 200 ppm	2	1,000 – 1,500 ohm-cm	8	
	0 – 50 ppm	0	1,500 – 2,500 ohm-cm	6	
Redox Potential	Negative	5	Soil Resistivity	2,500 – 5,000 ohm-cm	4
	0 – 100 mV	4		5,000 – 10,000 ohm-cm	2
				> 10,000 ohm-cm	0
	> 100 mV	0		---	--

**TABLE "31"**  
Overall Corrosivity Rating

SOIL CORROSIVITY	TOTAL POINTS
Severe	> 15.5
Appreciable	10.0 – 15.5
Moderate	5.0 – 9.5
Mild	0 – 4.5

- 6) Not included in Table "30" and "31" are conditions for stray current exposure, road salt run-off and foreign pipeline crossing.
- 7) Table "30" and "31" are adapted from Table 20.1 "Assessment of Overall Soil Corrosivity to Steel", C.P. Dillon *Corrosion Control in the Chemical Process Industries*. Materials Technology Institute of the Chemical Process Industries, 1994.



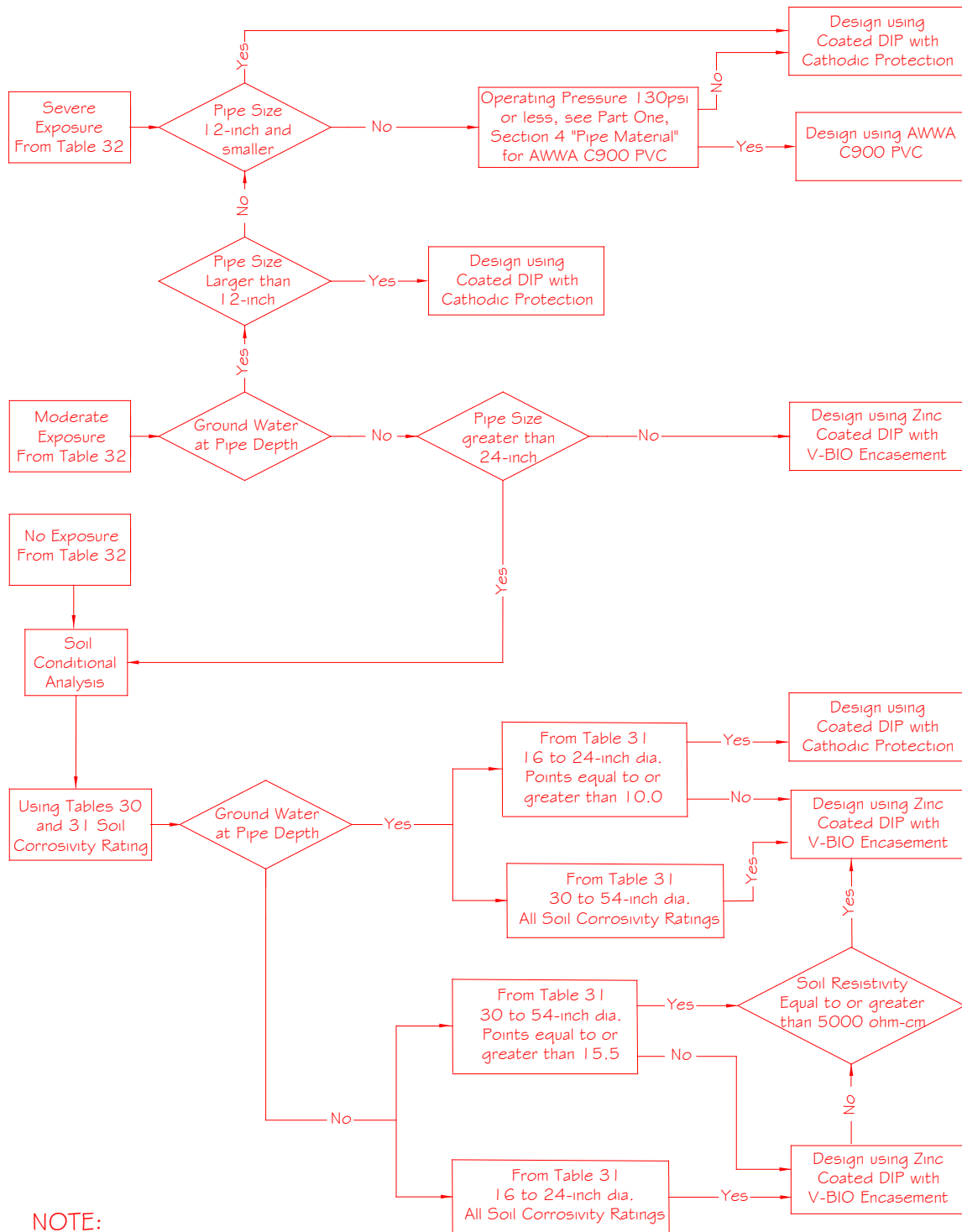

**NOTE:**

1. "Coating" means a bonded high performance coating.

**CHART "C"**

Corrosion Control Decision Tree For New Ductile Iron Pipelines



**e. Stray Current Analysis.**

- 1) A Stray Current Analysis is required for all sizes of water pipelines and metallic sewer pipelines.
- 2) First, identify the source of stray currents. Examples of stray current sources are listed below:
  - a) Impressed current cathodic protection systems which may be located along petroleum product, natural gas or cryogenic liquids pipelines, at bulk storage facilities with ASTs (Aboveground Storage Tanks) with grade level bottoms or USTs (Underground Storage Tanks), at gas stations or other locations along buried pipe-type electric, telephone, or other communication cables, and at public or private housing complexes with on-site gas distribution systems (including military bases), WSSC transmission water pipelines, or metallic sewer pipelines.
  - b) Electrified rail systems, such as at-grade or underground WMATA Metrorail lines, AMTRAK lines, or Maryland Transit Administration (MTA) at grade rail lines. The locations of MTA TPSS (Traction Power SubStations) and distances from WSSC pipelines need to be documented.
  - c) Welding shops and other industrial facilities.
- 3) Testing for Stray Current.
  - a) When there is an existing stray current source within two thousand (2000) feet of water pipeline or metallic sewer line, use a recording type instrument with a minimum sample rate of one reading per second for detecting possible stray current influence. Conduct one hour tests in each location if requested by WSSC Technical Services Group. Obtain readings of a portable reference cell to structure potential and two portable reference cells spaced one hundred feet apart. If WMATA or MTA rail lines are the source of stray current, conduct testing during peak operating hours (6:00 AM to 10:00 AM or 3:00 PM to 7:00 PM) A Corrosion Engineer, a NACE Certified Senior Corrosion Technologist or a NACE Certified CP or Corrosion Specialist is to oversee the stray current testing.
  - b) No testing is required if there are no stray current sources identified within two thousand (2000) feet or if the ductile iron pipeline will be within two hundred (200) feet of WMATA Metrorail electrified AMTRAK, or Maryland Transit Administration (MTA) lines. When within two hundred (200) feet of WMATA Metrorail, electrified AMTRAK, or MTA lines, take protective measures in accordance with Severe Exposure in Table "32".
- 4) Decision Process.
  - a) Make a site visit and determine the presence of possible stray current sources and perform testing as required to verify and quantify stray current in the vicinity of the pipeline.
  - b) Using Table "32" determine the level of exposure to stray currents and go to Chart "D", to determine what, if any, corrosion control measures are needed.
- 5) For the purpose of this analysis, *ground bed* refers to impressed current cathodic protection anodes, and *foreign* refers to another buried utility pipe or cable, including an existing WSSC pipeline. Foreign pipe that is not of concern includes non-metallic materials such as PVC and prestressed concrete cylinder pipe that typically does not have impressed current cathodic protection.



**TABLE "32"**  
Stray Current Analysis

<u>Exposure Level to Stray Currents</u>	<u>Pre-Construction Survey and Test Results</u>
<u>SEVERE EXPOSURE</u>	<ul style="list-style-type: none"> <li>• Continual stray current that results in more than 50 mV potential variation (any source).</li> <li>• WMATA Metrorail, <b>electrified AMTRAK</b>, or <b>Maryland Transit Administration (MTA) lines</b>, or <b>Maryland Transit Administration (MTA) Traction Power Substation (TPSS)</b> that are within 200 feet of the pipeline.</li> <li>• Future/proposed extension of WMATA Metrorail lines, <b>electrified AMTRAK</b>, <b>Maryland Transit Administration (MTA) lines</b>, or <b>Maryland Transit Administration (MTA) Traction Power Substation (TPSS)</b> within 500 feet of the pipeline.</li> <li>• Cathodically protected foreign buried pipes or cables that cross or come within 100 feet of the pipeline and have a ground bed within 2000 feet.</li> </ul>
<u>MODERATE EXPOSURE</u>	<ul style="list-style-type: none"> <li>• Moderate or sporadic stray current that results in 50 mV or less potential variation (any source).</li> <li>• WMATA Metrorail, <b>electrified AMTRAK</b>, <b>Maryland Transit Administration (MTA) lines</b>, or <b>Maryland Transit Administration (MTA) Traction Power Substation (TPSS)</b> that is within 200 to 500 feet of the pipeline.</li> <li>• Cathodically protected foreign buried pipes or cables that are within 100 to 500 feet of the pipeline and have a ground bed within 2000 feet or that cross the pipeline and have a ground bed over 2000 feet away.</li> </ul>
<u>NO EXPOSURE</u>	<ul style="list-style-type: none"> <li>• No stray current detected during testing.</li> <li>• WMATA Metrorail, <b>electrified AMTRAK</b>, and <b>Maryland Transit Administration (MTA) lines</b> or <b>Maryland Transit Administration (MTA) Traction Power Substation (TPSS)</b> beyond 500 feet away from the pipeline.</li> <li>• Cathodically protected foreign utility buried pipes and cables are more than 500 feet away from the pipeline.</li> </ul>

**f. Existing Pipe Analysis.**

- 1) An Existing Pipe Analysis is required for all sizes of water pipelines. Determine what corrosion control measures will be required at the connection between the existing and new pipeline(s).
- 2) Determine if any corrosion control measures were used on the existing pipe to which the new pipe will be connected.
- 3) Identify the existing pipeline material (ductile iron, cast iron, prestressed concrete cylinder, steel, etc.).



## 4) Decision Process.

- a) Using Chart "D" and the type of existing pipe material, determine what corrosion control measures are required.
- b) If Stray Current Analysis indicates Moderate or Severe Exposure these results shall supersede the results of the Soil Condition Analysis and Existing Pipe Analysis.
- c) If the combination of the results from both the Stray Current Analysis and Soil Condition Analysis are at least moderate or higher, then DIP with Special Exterior Coated Pipe with cathodic protection is required.

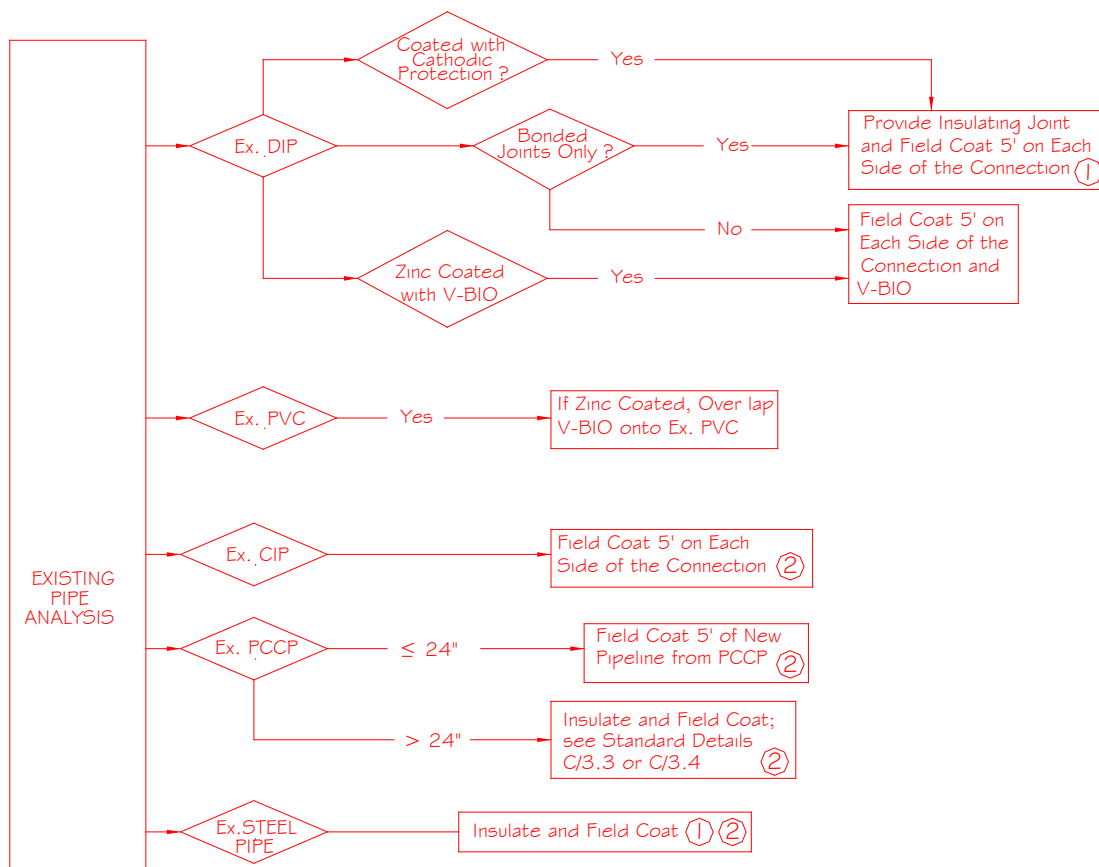

① If existing pipe has a bonded coating (epoxy, coal tar enamel, polyethylene back tape, etc.), over lap field coating onto existing pipe coating a minimum of 6".

② When V-BIO is used on new pipe, overlap it onto the field coating.

### CHART "D"

Corrosion Control Decision Tree Connecting For To Existing Ductile Iron Pipelines



**g. Corrosion Survey Checklist.**

- 1) The information below includes instructions on how to complete the Corrosion Survey Checklist and describes the items on the checklist in greater detail. Select an alignment that avoids areas where special corrosion control measures are likely to be required. Note the results of the investigation of these issues on the Corrosion Survey Checklist and include the completed checklist with the **first submittal**.
  - a) Complete the existing pipe analysis for all connecting pipe sizes, to include type of pipe material, sizes, pipeline type, existing corrosion control, if any, and corrosion control required from Chart "D". **If stray current testing or soil analysis testing is required, complete this item as "To be determined after testing completed and results analyzed."** Use Chart D only if all items in section b) are marked no, and pipeline is less than 16 inch.
  - b) Identify the sources of stray currents, including buried utilities or transportation facilities in the vicinity (crossing, parallel or within two thousand (2000) feet) of the pipeline alignment that may be a source of stray current. Potential stray current sources are listed below.
    - (1) Washington Metropolitan Area Transit Authority (WMATA) DC transit lines, **electrified AMTRAK and Maryland Transit Administration (MTA) Rail Lines, especially surface routes. Also note location of MTA TPSS.**
    - (2) **Petroleum Product, Natural Gas, or Cryogenic Liquids** pipelines with impressed current cathodic protection systems.
    - (3) **Direct Burial or Pipe Type communication or power cables with impressed current cathodic protection systems.**
    - (4) **Overhead transmission high voltage electrical lines that are in a parallel or perpendicular right of way. This refers to lines mounted on towers not residential / commercial distribution poles.**
    - (5) **Impressed cathodic protection systems at locations with USTs containing petroleum products, including but not limited to: bulk storage facility, retail gas stations, trucking terminals or warehouses, hospitals, schools, and large commercial or residential properties.**  
UST locations in project areas can be found using the following link from the Maryland Department of Environment (MDE):  
  
**<http://mes-mde.mde.state.md.us/FacilitySummary/default.aspx>**  
  
The UST information available in the link above states the tank and piping material and whether cathodic protection is installed. This information will be used to complete Corrosion Survey Checklist, part b) (5).
  - c) Indicate on the checklist if the pipeline will be exposed to any of the following corrosive conditions which will impact the corrosion rate of a metallic pipeline and influence the selection of pipe coatings or the need for cathodic protection or alternative materials.
    - (1) Deicing salt exposure, typically encountered when the pipeline is located beneath a roadway stormwater drainage ditch, infiltration trench, etc.





- (2) Relocation of pipelines in older areas where the streets have cinders that may have been dumped before the streets were paved.
- (3) Exposure to chemical or animal waste runoff from nearby farms.
- (4) Wetlands and sites containing significant deposits of organic soils, such as peat.
- (5) Pipe exposed to continuously wet or submerged environments.
- (6) Cyclic wetting and drying due to a fluctuating groundwater table.
- (7) Soil type generally corrosive to buried metals, as indicated in the United States Department of Agriculture Soil Conservation Services Soil Surveys for Prince George's County and Montgomery County, such as acid sulfate soils.
- (8) History of pipe leaks or breaks in the vicinity.
- (9) Size and importance of the pipeline. Water or metallic sewer pipelines 16-inch and greater are typically candidates for more stringent corrosion control measures. For all water and metallic sewer pipelines 16-inch and greater, perform the soil and groundwater testing indicated at the bottom of the checklist and submit the results with the **second submittal**.
- (10) If the pipeline will be connected to an existing pipeline or another pipeline which was or will be constructed with dissimilar metal that may create conditions for a galvanic corrosion cell, identify the type and size of the existing pipe and the original WSSC contract number. For prestressed concrete cylinder pipe, also identify the manufacturer's project number and if the pipe is embedded cylinder type (SP-12) or lined cylinder type (SP-5). Also, identify the type of corrosion control on the existing pipeline, if any.

#### **h. FORM "B" Corrosion Documentation.**

- 1) Following the completion of any required Soil Condition Analysis, Stray Current Analysis and Existing Pipe Analysis complete the Corrosion Documentation, Form "B" and submit it with the **second submittal**.
- 2) Determine what type of corrosion control is required and indicate the type at the bottom of Form "B".



**CORROSION SURVEY CHECKLIST**

PROJECT NAME \_\_\_\_\_ CONTRACT NO.: \_\_\_\_\_

PREPARER (Please print): \_\_\_\_\_ TITLE: \_\_\_\_\_

SIGNATURE OF PREPARER: \_\_\_\_\_ DATE: \_\_\_\_\_

COMPANY NAME OF PREPARER: \_\_\_\_\_

**a) Existing Pipe Analysis: (all pipe sizes, list only the pipe sizes to be replaced/relocated).**

Size(s) \_\_\_\_\_ Pipeline Type: \_\_\_\_\_ Note: Provide any additional supporting information on a separate sheet of paper.

Connecting to: \_\_\_\_\_  
 \_\_\_\_\_ CIP \_\_\_\_\_ Water Pipeline  
 \_\_\_\_\_ DIP \_\_\_\_\_ Force Main  
 \_\_\_\_\_ PCCP \_\_\_\_\_ Other \_\_\_\_\_  
 \_\_\_\_\_ Steel Existing Pipe Corrosion Control:  
 \_\_\_\_\_ Other \_\_\_\_\_ none \_\_\_\_\_ Bonded Joints \_\_\_\_\_ Coated Type: \_\_\_\_\_  
 \_\_\_\_\_ Cathodic Protection: \_\_\_\_\_ Galvanic Anodes \_\_\_\_\_ Impressed Current

Corrosion Control Required (from Chart "D"): \_\_\_\_\_

**b) Identify Sources of Stray Currents (crossing, parallel or within 2000 feet).**

- (1) Yes  No  WMATA DC transit lines, electrified AMTRAK, and Maryland Transit Administration (MTA), especially surface routes, and MTA TPSS.
  - (2) Yes  No  Petroleum Product, Natural Gas, or Cryogenic Liquids pipelines with impressed current cathodic protection systems.
  - (3) Yes  No  Pipe Type communication or power cables with impressed current cathodic protection systems.
  - (4) Yes  No  Overhead transmission high voltage electrical lines that are in a parallel or perpendicular right of way.
  - (5) Yes  No  UST locations with impressed current cathodic protection systems.
- If (1) to (5) is answered Yes, provide stray current analysis

**c) Additional Corrosion Considerations.**

- (1) Yes  No  Exposure to deicing salts.
- (2) Yes  No  Relocation in older streets.
- (3) Yes  No  Exposure to chemical or animal waste runoff from nearby farms or golf courses.
- (4) Yes  No  Wetlands and sites containing significant deposits of organic soils, such as peat.
- (5) Yes  No  Pipe exposed to continuously wet or submerged environments.
- (6) Yes  No  Cyclic wetting and drying due to a fluctuating groundwater table.
- (7) Yes  No  Soil type generally corrosive to buried metals (i.e., acid sulfate soils).
- (8) Yes  No  History of pipe leaks or breaks in the vicinity.
- (9) Yes  No  Proximity to highly break or leak sensitive areas (dams, buildings, bridges, etc.).
- (10) Yes  No  Water or metallic sewer pipelines 16-inch or larger? If yes, perform the soil and groundwater testing indicated below and include the results with the second submittal.

**d) Field Soil And Groundwater Testing Requirements for All Ductile Iron Pipelines 16-inch and Larger. (See Appendix "E" for Specific Testing Requirements; submit with second submittal).**

- (1) pH measurements (ASTM G 51) on the jar sample collected nearest the proposed pipe depth.
- (2) Water soluble chloride content (ASTM D 512) of soil at the proposed pipe depth. Chloride ion extraction using accepted industry methodology prior to testing.
- (3) Redox potential (ASTM D 1498) of soil at the proposed pipe depth.
- (4) Soil description at pipe depth and groundwater level as determined from soil boring logs.
- (5) Soil resistivity measurements (ASTM G 57) on the bag sample collected at the proposed pipe depth.



**FORM "B"**  
**Corrosion Documentation**

Date \_\_\_\_\_

**1. Job Description:**

Contract Number \_\_\_\_\_ City, County: \_\_\_\_\_  
 Map Book Page and Grid: \_\_\_\_\_  
 Type of Job: \_\_\_\_\_ New Pipeline. \_\_\_\_\_ Relocation. \_\_\_\_\_ Same Trench Replacement  
 New Pipe: \_\_\_\_\_ Size(s): \_\_\_\_\_ Type of Pipeline \_\_\_\_\_  
 \_\_\_\_\_ DIP \_\_\_\_\_ Steel \_\_\_\_\_ Water Pipeline \_\_\_\_\_ Force main  
 \_\_\_\_\_ PCCP \_\_\_\_\_ Other \_\_\_\_\_

**2. Site Evaluation:**

**a) Existing Pipe Analysis:** (all pipe sizes).

Size(s) \_\_\_\_\_ Existing Pipe Corrosion Control: \_\_\_\_\_  
 Connecting to: \_\_\_\_\_ none  
 \_\_\_\_\_ CIP \_\_\_\_\_ Bonded Joints  
 \_\_\_\_\_ DIP \_\_\_\_\_ Coated: Type: \_\_\_\_\_  
 \_\_\_\_\_ PCCP \_\_\_\_\_ Cathodic Protection: Type: \_\_\_\_\_ Anodes  
 \_\_\_\_\_ Steel \_\_\_\_\_ Impressed Current  
 \_\_\_\_\_ Other \_\_\_\_\_  
 Corrosion Control Required (from Chart "D"): \_\_\_\_\_

**b) Stray Current Analysis:** (all pipe sizes).

\_\_\_\_\_ WMATA Rail Line:  
 \_\_\_\_\_ Parallel (feet): \_\_\_\_\_ Crossing. \_\_\_\_\_ Subway. \_\_\_\_\_ At Grade.  
 \_\_\_\_\_ Maryland Transit Administration (MTA):  
 \_\_\_\_\_ Rail Line: \_\_\_\_\_ Parallel (feet): \_\_\_\_\_ Crossing. \_\_\_\_\_ At Grade.  
 \_\_\_\_\_ TPSS: \_\_\_\_\_ Parallel (feet): \_\_\_\_\_ Crossing.  
 \_\_\_\_\_ Cathodically Protected Petroleum Product, Natural Gas, or Cryogenic Liquid Pipelines:  
 \_\_\_\_\_ Impressed Current. \_\_\_\_\_ Magnesium Anode. Proximity of Ground Beds (feet): \_\_\_\_\_  
 \_\_\_\_\_ Electric: Direct Burial Cables. \_\_\_\_\_ Pipe-Type Cables \_\_\_\_\_ Overhead High Voltage. \_\_\_\_\_  
 \_\_\_\_\_ Telephone.  
 \_\_\_\_\_ UST locations with impressed current cathodic protection systems.  
 Distance of USTs from proposed project (feet): \_\_\_\_\_  
 \_\_\_\_\_ Other: \_\_\_\_\_

**c) Soil Condition Analysis:** (16-inch and larger pipeline, or less than 16 inch when requested).

Results from Table 31:

Boring # _____	Point Total: _____	Rating _____
Boring # _____	Point Total: _____	Rating _____
Boring # _____	Point Total: _____	Rating _____
Boring # _____	Point Total: _____	Rating _____
Boring # _____	Point Total: _____	Rating _____
Boring # _____	Point Total: _____	Rating _____

Note: Provide any additional Point totals on a separate sheet of paper.

**3. Corrosion Control Requirements (based on results of Stray Current Analysis and Soil Condition Analysis):**

- \_\_\_\_\_ Polyethylene Encasement with zinc basecoat applied to pipe surface and asphaltic topcoat, outer most layer to be polyethylene.
- \_\_\_\_\_ Externally coated pipe (Pritec or equal) with cathodic protection system (galvanic or impressed current) to include bonded joints, test stations, and insulating joints between new and existing pipelines, and insulating joints on WHCs 3 inches or larger.





# APPENDIX

## TABLE OF CONTENTS

### APPENDIX

<b>Appendix A</b>	<b>Design Checklist</b>	<b>Appendix A-1</b>
<b>Appendix B</b>	<b>WSSC Design Criteria for Water Distribution Systems.</b>	<b>Appendix B-1</b>
	a. System Requirements.	Appendix B-1
	b. Hydraulic Design Criteria.	Appendix B-2
	c. Non-Hydraulic Alignment Considerations.	Appendix B-9
<b>Appendix C</b>	<b>WSSC Design Criteria for Sewer Systems</b>	<b>Appendix C-1</b>
	a. System Requirements.	Appendix C-1
	b. Determining Flows.	Appendix C-3
	c. Hydraulic Design	Appendix C-6
<b>Appendix "D"</b>	<b>WSSC Survey and Right of Way Criteria</b>	<b>Appendix D-1</b>
	a. General Survey Information.	Appendix D-1
	b. Surveying Control.	Appendix D-2
	c. Field Survey Standards	Appendix D-2
	d. As-build Surveys	Appendix D-5
	e. Stakeout Information and Width of Easements and Construction Strips.	Appendix D-7
	f. Survey Checklist.	Appendix D-7
	g. WSSC Easement Standards.	Appendix D-10
<b>Appendix "E"</b>	<b>Subsurface Investigation Requirements for Water and Sewer Design and Construction</b>	<b>Appendix E-1</b>
	a. General Requirements	Appendix E-1
	b. Soil Borings.	Appendix E-1
	c. Laboratory Testing.	Appendix E-5
	d. In-situ Tests	Appendix E-6
	e. Boring Logs and other Logs.	Appendix E-6
	f. Geotechnical Report Requirements	Appendix E-6
	g. Submittals.	Appendix E-8
<b>Appendix "F"</b>	<b>Soil Investigation for Soft Ground Tunnel Projects</b>	<b>Appendix F-1</b>
	a. General Requirements	Appendix F-1
	b. Soil Borings.	Appendix F-1
	c. Laboratory Testing.	Appendix F-3
	d. In-situ Tests	Appendix F-4
	e. Geophysical.	Appendix F-4
	f. Geotechnical Report Requirements	Appendix F-5
	g. Submittals.	Appendix F-5
	h. General Guidelines and Checklist for Subsurface Investigations	Appendix F-6
	i. Referenced ASTM standards for General Guidelines and Checklist for Subsurface Investigations.	Appendix F-10
	j. Example gINT Reports.	Appendix F-10



## TABLES

<b>Table "8"</b>	Guidelines for Estimating Maximum Day Demand in Existing Mains.	Appendix B-3
<b>Table "9a"</b>	Hazen-Williams "C" Coefficients for Lined Pipes.	Appendix B-4
<b>Table "9b"</b>	Estimating "C" Coefficients in Unlined Mains.	Appendix B-11
<b>Table "19"</b>	Minimum Slope of Sewer Pipelines.	Appendix C-2
<b>Table "19a"</b>	Development Flow Factors- By Dwelling Type.	Appendix C-3
<b>Table "19b"</b>	Development Flow Factors- By Employee Type.	Appendix C-3
<b>Table "19c"</b>	Development Flow Factors- By Specific Use.	Appendix C-4
<b>Table "19d"</b>	Non-Residential Flow Factors By Zoning For Montgomery County	Appendix C-4
<b>Table "19e"</b>	Non-Residential Flow Factors By Zoning For Prince George's County	Appendix C-4
<b>Table "19f"</b>	Residential Flow Factors By Zoning For Montgomery County	Appendix C-5
<b>Table "19g"</b>	Residential Flow Factors By Zoning For Prince George's County	Appendix C-6

## CHECKLISTS

Design Checklist	Appendix A-1
Survey Checklist.	Appendix D-2



## APPENDIX A

### DESIGN CHECKLIST

<input checked="" type="checkbox"/> CHECKED	CONTRACT NO. _____
<input type="checkbox"/> NOT APPLICABLE	SUBDIVISION/PROJECT _____
<input type="radio"/> OUTSTANDING OR TO BE ADDED	APPLICANT _____
	ARCHITECT/ENGINEER _____
	WSSC PROJECT MANAGER _____

Complete this checklist and include it along with each water and sewer pipeline design submittal. The checklist is to be signed and sealed prior to submission of final plans.

I certify that every reasonable effort has been made to obtain and review supporting data and prepare the drawings with knowledgeable consideration of all design factors, whether on this checklist or not, necessary for the proper and safe construction and operation of the water and/or sewer system shown thereon.

\_\_\_\_\_  
(Signature) (Engineer's Seal)

The Design Checklist serves as a guide for the preparation and review of water and sewer construction drawings. Any questions regarding items on the checklist will be referred to the WSSC for clarification. References to the applicable page number or section in the WSSC Pipeline Design Manual are in italic lettering.

### GENERAL DESIGN GUIDELINES

- \_\_\_ 1. Read **information provided by WSSC** in its entirety.
- \_\_\_ 2. Limits and sizes of proposed construction consistent with authorization. (If not, advise WSSC Project Manager prior to submittal.)
- \_\_\_ 3. Agreements (Paving Replacement, Relocations, etc.) Provide agreements or required information to WSSC Project Manager to initiate preparation of agreements.
- \_\_\_ 4. MBE Compliance Certification, if required.
- \_\_\_ 5. Submit all supporting data. (Plans will not be accepted without complete support information. All supporting plans must be approved prior to advertisement for construction.)
  - \_\_\_ a. Approved storm drain and paving plans.
  - \_\_\_ b. Approved street grades.
  - \_\_\_ c. Approved sediment control plans.
  - \_\_\_ d. Record plats.
  - \_\_\_ e. Site plans.
  - \_\_\_ f. On-site water and sewer plans.
  - \_\_\_ g. Existing water and sewer plans.



- \_\_\_ h. Other utility plans (gas, electric, phone, other pipelines, and cables). *Page G-7.*
- \_\_\_ i. Current topography in areas not to be graded.
- \_\_\_ j. Check for planned paving/resurfacing by County/State (Submit Correspondence).
- \_\_\_ k. Research and show on plan and profile all existing WHC'S and SHC'S in vicinity of proposed water and sewer extensions.
- \_\_\_ l. Copy of correspondence to WSSC regarding any necessary relocations and impact on existing facilities.
- \_\_\_ m. Site Contamination Screening Submittals *Page C-24.1.*
- \_\_\_ 1) Completed Environmental Questionnaire (*Page C-24-17*) including detailed explanation and applicable documentation for all "Yes" answers.
- \_\_\_ 2) If the WSSC was previously requested to conduct the database search, provide a copy of the request letter.
- \_\_\_ 3) If the WSSC was not requested to conduct the database search, provide a copy of the database search in accordance with ASTM E1527 including the database summary sheet or a Phase I Environmental Site Assessment report in accordance with ASTM E1527.
- \_\_\_ 4) If the pipeline must be located through a contaminated area, prepare the contract documents to comply with the conditional requirements for crossing contaminated areas. *Page C- 24.1.*
- \_\_\_ n. Pipeline alignment near or within Marlboro Clay. *Page C-19.3*
- \_\_\_ 6. Soil Borings. *Pages C-20.1 and C-26.5, Appendix E and Appendix F.*
- \_\_\_ a. Soil boring proposed location plan.  
(Approximate three hundred (300) foot interval - at intersection, vicinity of tunnels or wherever required for special design (e.g., blocking, structures)). *Page C-20.1, Appendix E and Appendix F.*
- \_\_\_ b. Minimum two (2) borings per contract. *Appendix E and Appendix F.*
- \_\_\_ c. Borings by developer, in accordance with Appendix E and F.
- \_\_\_ d. Coordinates (scaled) provided on each soil boring log.
- \_\_\_ e. Soil Data. *Pages C-20.1 and C-20.2, Appendix E and Appendix F.*
- \_\_\_ f. Soil Report required. *Pages C-20.1 and C-26.4.*
- \_\_\_ g. Soil and groundwater testing required for corrosion control design? ( \_\_ yes \_\_ no)  
*Pages C-28.5 and C-28.8.*
- \_\_\_ 7. Environmental. *Page C-8.1.*
- \_\_\_ a. All existing Sediment Control Devices (SCD) shown on plans and profiles. *Page C-8.4.*
- \_\_\_ b. No water and sewer alignments within fifty (50) feet of sediment control traps (draining ten (10) acres or more), basins, or water retention ponds. Alignments within fifty (50) feet shall be approved by WSSC on a case by case basis.
- \_\_\_ c. Approval date and number (SCD) shown for developer's sediment control in General Notes. *Page C-8.4.*
- \_\_\_ d. Show all sediment controls to be installed by contractor and reference by symbols (SBD, SF, etc.) *Pages C-8.4 thru C-8.15.*
- \_\_\_ e. Show 100 year flood plain delineation.
- \_\_\_ f. Show existing contours at five (5) foot intervals, in outfalls and flood plains, for a distance of one hundred (100) feet either side of pipe centerline.
- \_\_\_ g. Show drainage area at stream crossings. *Page C-8.2.*
- \_\_\_ h. Show all wooded area (delineation).
- \_\_\_ i. Show individual trees within fifty (50) feet of work area limits.





- \_\_\_ j. Show wetland boundaries and twenty (25) foot buffer delineation. One hundred (100) foot buffer where applicable. *Page C-23.1.*
- \_\_\_ k. Show Chesapeake Bay Critical Areas boundaries (delineation).
- \_\_\_ l. Show "Tree Save Areas" in vicinity of water and sewer lines in developments. *Page C-8.14.*
- \_\_\_ m. Show stabilized construction entrance. *Page C-8.9.*
- \_\_\_ 8. Tunnel Soil Investigation and Design. *Pages C-26.5 and Appendix F.*
- \_\_\_ a. WSSC tunnel meeting.
- \_\_\_ b. Preliminary tunnel submittal. (Natural scale tunnel profiles with details and results of soils investigations). *Page C-26.5.*
- \_\_\_ c. Tunnel Geotechnical Report required. (\_\_\_ yes \_\_\_ no). *Page C-26.5.*
- \_\_\_ d. Evaluation of pipe failure and settlement. *Page C-26.11.*
- \_\_\_ e. Environmental concerns (blasting, utilities, water quality, etc.).
- \_\_\_ f. Water table and dewatering. *Pages C-26.16 and C-26.17.*
- \_\_\_ g. Comply with MSHA and/or railroad authority requirements. *Pages C-25.1 thru C-25.3.*
- \_\_\_ h. Sufficient construction access. *Page C-26.16.*
- \_\_\_ i. Tunnel Access Manhole for tunnels/casings greater than twenty (20) feet. *Page -26.17*
- \_\_\_ 9. Thrust Restraint. *Page C-27.1*
- \_\_\_ a. Thrust Restraint Schedule, Form "A". *Page C-20.1 and page C-20-Form A-1.*
- \_\_\_ b. Thrust Restraint Calculations. *Page C-20.2.*
- \_\_\_ 10. Corrosion Control. *Page C-28.1.*
- \_\_\_ a. Corrosion Survey Checklist. *Pages C-20.9 and C-28.11.*
- \_\_\_ b. Corrosion Documentation, Form "B". *Pages C-28.10 and C-28.12.*
- \_\_\_ c. Corrosion Control plan and specifications. *Page C-28.1.*
- \_\_\_ 11. Horizontal Separation with Other Utilities/Structures. *Page C-3.11.*
- \_\_\_ a. Minimum separation of five (5) feet from existing or proposed structures and other utilities (manholes, inlets, poles, storm drains, conduits, gas mains, etc. *Page C-3.11.*
- \_\_\_ b. Minimum separation with water and sewer pipelines with existing or proposed buildings or dwellings.
- \_\_\_ 1) Water pipelines 12-inches and smaller, minimum separation of fifteen (15) feet to existing or proposed buildings or dwellings. *Page C-3.11.*
- \_\_\_ 2) Water pipelines larger than 12-inches, minimum separation of twenty-five (25) feet to existing or proposed buildings or dwellings. *Page C-3.11*
- \_\_\_ 3) Sewer pipelines 12-inches and smaller, minimum separation of fifteen (15) feet to existing or proposed buildings or dwellings. *Page C-3.2.*
- \_\_\_ 4) Sewer pipelines larger than 12-inches, minimum separation of twenty-five (25) feet to existing or proposed buildings or dwellings. *Page C-3.11.*
- \_\_\_ c. Minimum separation of ten (10) feet (OD to OD) between water and sewer pipelines. *Page C-3.11.*



## BASIC PLAN

- \_\_\_ 1. General
- \_\_\_ a. Title (1st line - election district, 2nd line - project description, 3rd line - street names, 4th line - subdivision name and part number).
- \_\_\_ b. Vicinity Map - sheet #1 (upper right, over title block) Show layout of streets clearly sufficient for contractor's access; show locator map page and grid no. (Indicate contract number on map).
- \_\_\_ c. Contract number.
- \_\_\_ d. Project number (water and/or sewer, (e.g., S-75.01, W-80.03). Located over title block.
- \_\_\_ e. Permit identification/as-built information/drawing index on Sheet #1.  
Two-hundred (200) foot sheet and fifty (50) foot sheet numbers added.
- \_\_\_ f. Scales. *Page G-1.*
- \_\_\_ g. North arrow (generally pointing to top of sheets).
- \_\_\_ h. Engineer's name, address, phone number.
- \_\_\_ i. Developer's/Applicant's name, contact persons, address, and phone number.
- \_\_\_ j. Drainage basin (over title block).
- \_\_\_ k. Service categories shown (lower left-hand corner).
- \_\_\_ l. "Inspection Only" noted if required (lower right hand corner, first sheet).
- \_\_\_ m. Street names (label "Private" where applicable), lot and parcel numbers, lot frontages and block numbers.
- \_\_\_ n. Miss Utility Note.
- \_\_\_ o. MSHA Route No. (interstate, if applicable) on plan view and vicinity map.  
1) Show ADT and MPH.
- \_\_\_ p. Montgomery County Roads - traffic control plan.
- \_\_\_ q. Prince George's County Roads.  
1) ADT shown.  
2) Traffic control plan.
- \_\_\_ r. Show authorization date (left border).
- \_\_\_ s. Property owner(s) names and addresses along improved roads and outfalls. Show existing houses.
- \_\_\_ 2. General Notes (on 1st sheet only).
- \_\_\_ a. Water pipe type or class; criteria; options. *Page W-2.1 and W-4.1.*
- \_\_\_ b. Sewer pipe type or class; options; exceptions. *Page S-3.1 and S-3.2.*
- \_\_\_ c. WHC; size; account numbers. Outside meters noted, if required.  
*Pages W-25.1 thru W-25.8.*
- \_\_\_ d. SHC; size; account numbers. SHC connected to a sewer main with a slope of 1% or less shall have a T-Wye fitting at the main line connection. *Pages S-27.1 and S-27.2*
- \_\_\_ e. Property corner/survey control note. *Page C-1.1 and Appendix D.*
- \_\_\_ f. All DI water mains and sewer mains to be minimum class 54 ductile iron pipe.  
*Pages W-4.1 and S-3.3.*
- \_\_\_ g. All DI water mains and sewer mains to be **V-Bio encased Zinc Coated Pipe**, following AWWA C105. *Page W-2.1 and S-3.1*
- \_\_\_ h. All DI sewer pipes to be lined following WSSC specifications. *Page S-3.1.*
- \_\_\_ i. Sediment Control notes. *Pages C-8.1 and C-8.2.*
- \_\_\_ j. WHC curb stop location specified where not on property line. *Page W-25.3 and W-25.4.*
- \_\_\_ k. Special notes shown for contracts where construction is not under this contract.
- \_\_\_ l. Notification required when construction is within town or city limits.





- \_\_\_ c. Montgomery County Department of Permitting Services (MCDPS)
  - \_\_\_ 1) Traffic Control Plan may be required on streets with a seventy (70) foot right of way or greater. For inquiries, contact MCDPS. Show traffic control plans on standard WSSC plan size (except in cases where 8 1/2" x 11" sketches are acceptable).
  - \_\_\_ 2) Rural-Rustic Roads. At the request of MCDPS, a field site meeting may be required with MCDPS and WSSC. Centerline stakeout and additional drawings may be required.
- \_\_\_ d. Maryland Department of Environment, Water Management Administration
  - \_\_\_ 1) Maintain twenty five (25) feet from nearest stream bank to edge of work limits. *Page C-9.2.*
  - \_\_\_ 2) Design stream crossing with three (3) feet minimum cover over proposed main. *Pages W-11.1 and S-8.2.*
  - \_\_\_ 3) Show property owner's name and address.
  - \_\_\_ 4) Tidal Wetlands Division.
    - \_\_\_ a) 8 1/2" x 11" sketches will be required.
  - \_\_\_ 5) Nontidal Wetlands Division. *Page C-23.1.*
    - \_\_\_ a) Show property owner's name and address.
    - \_\_\_ b) Show environmental consultant on the plan above the title block in the vicinity of applicant information.
    - \_\_\_ c) Add previous wetland permit approval(s) (include number of permit).
    - \_\_\_ d) Wetlands standard notes on drawings. *Pages C-23.1 and C-23.2.*
  - \_\_\_ 6) Army Corps of Engineers.
    - \_\_\_ a) 8 1/2" x 11" sketches will be required.
- \_\_\_ e. Prince George's County – all existing roadways in Prince George's County (PGDPWT)
- \_\_\_ f. Maryland State Highway Administration (SHA permit).
- \_\_\_ g. **Maryland Department of Environment (MDE) Permit for Water and Sewer Construction greater than 15-inch diameter for water and sewer pipelines and all force mains.**

### PRELIMINARY WATER

- \_\_\_ 1. Minimum size 4" for mainline water pipelines, Minimum size 8" with fire hydrants. *Page W-24.2 and page App. B-5.*
- \_\_\_ 2. Sizes indicated on plan and profile. *Pages W-8.2 and W-11.2.*
- \_\_\_ 3. Fire hydrants shown five hundred (500) feet in single family developments; two hundred fifty (250) to three hundred (300) feet in townhouse developments or industrial/commercial. Generally located on lot lines or consistent with proposed driveways, parking bays, etc. *Pages W-24.1 - W-24.3.*
- \_\_\_ 4. Valves. *Page W-18.1*
  - \_\_\_ a. All small mains off larger mains. *Page W-18.1*
  - \_\_\_ b. Valves to be located to provide line shutdown limited to fifty (50) units, or two blocks maximum.
  - \_\_\_ c. Indicate division valves and pressure zone lines where applicable. *Page W-18.2*
  - \_\_\_ d. Double valves required (6" - 12", laterals from 42" and up). *Page W-18.2*
  - \_\_\_ e. Valves on all fire hydrant leads. *Page W-18.1*



- \_\_\_ 5. Show WHC to each lot, parcel or building (indicate location of WHC curb stops if standard location conflicts with sidewalk/curb and gutter; on projects with tertiary streets, extend WHC's to limits of PUE or PIE easement). *Page W-25.4.*
- \_\_\_ 6. Profiles.
- \_\_\_ a. Indicate approved grade by agency and date (or finished grade from development plan). Establish street grades if required. *Page W-11.3.*
- \_\_\_ b. Design main with four (4) feet of cover below proposed grade for new street (deep subgrade - new County and MSHA roads should be considered at this time; existing or proposed ground in developed streets). *Pages W-11.1 thru W-11.3.*
- \_\_\_ c. Minimum one and half (1.5) foot clearance of existing or proposed water sewer, WHC, SHC. *Page C-3.1.*
- \_\_\_ d. **Minimum one (1) foot clearance of existing or proposed utilities (water, sewer, WHC, SHC, with storm drains, gas, electric, telephone, etc.).** *Page C-3.1.*
- \_\_\_ e. Class of pipe consistent with depth. *Page W-4.1*
- \_\_\_ 7. Plan - Alignment. *Page W-8.1.*
- \_\_\_ a. Minimum separation of ten (10) feet from existing or proposed sewer (OD to OD). *Page C-3.12.*
- \_\_\_ b. Minimum separation of five (5) feet from existing or proposed storm drains, inlets, poles, gas mains, conduits, etc. *Page C-3.11.*
- \_\_\_ c. **Locating water pipeline in road section** *Page W-8.1.*
- \_\_\_ d. Minimize specifying bends. *Page W-7.2.*
- \_\_\_ e. Maximum joint deflection not utilized in horizontal and vertical plane simultaneously. *Pages W-11.2 and W-12.1.*
- \_\_\_ f. Sufficient plan and profile shown for future extensions. *Page W-11.4.*
- \_\_\_ g. Minimum pipe radii:
- \_\_\_ 1) **DIP Pipe Push on Joint** *Page W-12.1.*  
     4" to 12" = 290 ft  
     14" and greater = 480 ft
- \_\_\_ 2) **DIP Mechanical Joint** *Page W-12.2.*  
     4" to 12" = 290 ft  
     14" to 20" = 480 ft  
     24" and greater = 720 ft
- \_\_\_ 3) **Wedge Action Restraining Glands- Mechanical Joint DIP** *Page W-12.3.*  
     4" to 12" = 290 ft  
     14" to 20" = 480 ft  
     24" and greater = 720 ft
- \_\_\_ 4) **Manufacturer's Proprietary Restrained Joint DIP- Push-on Restrained Joint Gaskets** *Page W-12.3.*  
     4" to 12" = 290 ft  
     14" to 24" = 480 ft
- \_\_\_ 5) **Manufacturer's Proprietary Restrained Joint DIP** *Pages W-12.3 and W-12.4.*  
     14" to 16" = 480 ft  
     18" to 30" = 820 ft  
     36" to 54" = 2860 ft
- \_\_\_ 6) **Wedge Action Restraining Glands- DIP Push-on Joints** *Page W-12.4.*  
     4" to 12" = 290 ft  
     14" to 48" = 480 ft



- \_\_\_ 7) **PVC Pipe with Push on Joints** *Page W-12.1.*  
4" to 12" = 820 ft
- \_\_\_ 8) **Push-on PVC Pipe with Wedge Action Restraining Glands** *Page W-12.4.*  
4" to 12" = 820 ft
- \_\_\_ h. **Blocking.** *Page C-27.1.*
  - \_\_\_ 1) Thrust Restraint Schedule, Form A. *Pages C-20.2, C-20-Form A-1.*
- \_\_\_ i. **Corrosion Control.** *Page C-28.1.*
  - \_\_\_ 1) Corrosion Survey Checklist. *Pages C-28.2, C-28.9 and C-28.11.*
  - \_\_\_ 2) Corrosion Documentation, Form "B". *Pages C-28.2, C-28.10 and C-28.12.*

### PRELIMINARY SEWER

- \_\_\_ 1. Sizes and direction of flow indicated on plan. *Page S-5.2.*
- \_\_\_ 2. Minimum pipe size for mainline sewer pipelines. *Page S-2.1.*
- \_\_\_ 3. Computations submitted, if required.
- \_\_\_ 4. Sufficient plan and profile shown for future extensions. *Page S-8.5.*
- \_\_\_ 5. Basement elevations shown on plan and profile. If only first floor service is to be provided, verify adequate cover over SHC within the property. (Existing and proposed houses).  
*Page S-27.3.*
- \_\_\_ 6. Profile
  - \_\_\_ a. Sewers designed at normal depth, eight (8) to ten (10) feet, unless otherwise required by design. *Page S-8.1.*
  - \_\_\_ b. Minimum one and half (1.5) foot clearance of existing or proposed water sewer, WHC, SHC. *Page C-3.1.*
  - \_\_\_ c. **Minimum one (1) foot clearance of existing or proposed utilities (water, sewer, WHC, SHC, with storm drains, gas, electric, telephone, etc.).** *Page C-3.1.*
  - \_\_\_ d. Class of pipe consistent with depth. *Page S 3.3.*
- \_\_\_ 7. Plan - Alignment
  - \_\_\_ a. Minimum separation of ten (10) feet from existing or proposed sewer (OD to OD).  
*Page C-3.12.*
  - \_\_\_ b. Minimum separation of five (5) feet from existing or proposed storm drains, inlets, poles, gas mains, conduits, etc. *Page C-3.11.*
  - \_\_\_ c. **Locating sewer pipeline in road section** *Page S-5.1.*
- \_\_\_ 9. Plan
  - \_\_\_ a. SHC to each lot, parcel or building. *Page S-27.1.*
  - \_\_\_ b. Manholes, located to avoid sidewalks, if possible. *Page S-11.1.*
  - \_\_\_ c. Locate manholes out of parking areas where possible. *Page S-11.1.*
  - \_\_\_ d. Existing septic tanks and wells shown.
  - \_\_\_ e. Sewage flow tabulation chart on plan.



- \_\_\_ f. Manhole diameter consistent with angle of incoming and outgoing pipes.  
*Page S-14.1 thru S-14.4*
- \_\_\_ 10. Hydrogen Sulfide Control Evaluation. *Page S-28.1.* (Required for gravity sewers 27" and larger, force mains and pressure sewer grinder pump systems).
- \_\_\_ a. Calculations submitted. *Pages S-28.1 and S-28.2.*
- \_\_\_ b. Special manhole coating required. ( \_\_\_ yes \_\_\_ no)
- \_\_\_ c. Special pipe material or coating/lining required. ( \_\_\_ yes \_\_\_ no)

### FINAL GENERAL

- \_\_\_ 1. For water pipelines show LHG and HHG on plan (lower left corner). *Page W-5.1.*
- \_\_\_ 2. PE Stamp and Signature. *Pages G-7.*
- \_\_\_ 3. Field review note signed and dated within ninety (90) days of submission or advertisement.
- \_\_\_ 4. Dependency Note on plan. *Pages W-9.3 and S-5.4.*
- \_\_\_ 5. Tree protection. *Page C-8.14.*
- \_\_\_ 6. WHC and SHC information complete. *Pages W-25.1 and S-27.1.*
- \_\_\_ a. Size and Type (Standard or Right of Way).
- \_\_\_ b. Account Number.
- \_\_\_ c. Permit Number.
- \_\_\_ 7. Blocking Review. *Pages C-20.1 and C-27.1.*
- \_\_\_ a. Complete coverage. *Pages C-20-Form A-1 and C-20-Form A-2.*
- \_\_\_ b. Special blocking details and/or pipe restraint shown. *Pages C-27.2 and C-27.13.*
- \_\_\_ c. Fire hydrants **restrain all joints between fire hydrant and main.** *Page W-24.2.*
- \_\_\_ d. Existing special blocking and restrained joints shown on existing main at connections to existing pipe. *Page W-9.3.*
- \_\_\_ e. Existing ground behind plugs/caps (firm bearing for block). *Pages C-27.2 and C-27.27.*
- \_\_\_ f. Submit computations to support special blocking design. *Pages C-20.2 and C-27.2.*
- \_\_\_ g. If fitting is in fill, submit computations to assure standard blocking is sufficient.  
*Page C-27.2.*
- \_\_\_ 8. Valves and Fire Hydrants.
- \_\_\_ a. **Type of fire hydrant. Standard or High Traffic** *Page W-24.1*
- \_\_\_ b. Elbow elevation and fire hydrant lengths shown. *Page W-24.1.*
- \_\_\_ c. Fire hydrant extensions required. *Page W-24.1.*
- \_\_\_ d. Valve extension required. *Pages W-18.3 and W-18.6.*
- \_\_\_ e. **Locate valve next to tee** (existing and proposed). *Pages W-18.3 and W-18.6.*
- \_\_\_ f. Prepurchase valves. *Page W-18.6.*
- \_\_\_ g. Division valve - open/close valve requirement. *Page W-18.2.*
- \_\_\_ h. Fire hydrant facing note. *Page W-24.2.*
- \_\_\_ i. Salvage note for valves and fire hydrants. *Page C-5.1.*
- \_\_\_ j. Valves shall be placed on main where slope will allow valve to be operable. *Page W-18.3.*



- \_\_\_ 9. Tapping Sleeve and Valve (DIP) *Pages W-7.3 and W-7.4.*  
\_\_\_ a. Type of existing pipe shown. *Pages W-7.3 and W-7.4.*  
\_\_\_ b. Sufficient room to make tap. *Pages W-7.4 and W-9.2.*
- \_\_\_ 10. Connecting to PCCP  
\_\_\_ a. Show Lock Joint Number (if PCCP). *Page W-7.4.*  
\_\_\_ b. Not tapping PCCP. Must remove section(s) or PCCP *Page W-7.4.*
- \_\_\_ 10. Special structures: Blow-off, Air Valve, PRV'S, Thrust Vaults, etc. *Pages W-16.1, W-18.1, W-19.1, W-20.1, W-21.1 and W-22.1, thru C-22.13.*  
\_\_\_ a. Shown on plan and profile (drawn to scale).  
\_\_\_ b. Calculations submitted.
- \_\_\_ 11. Easements and Construction Strips. *Page C-2.1 and Appendix D.*  
\_\_\_ a. Executed (Date: \_\_\_\_\_).  
\_\_\_ b. Properly shown/described.  
\_\_\_ c. Property owner's name shown.  
\_\_\_ d. Special commitments.  
\_\_\_ e. Offset in easement, 15"S and larger (for future relief sewer). *Page C-2.3.*  
\_\_\_ f. Show existing right of way with liber/folio on easement affected by current design.  
\_\_\_ g. Special considerations for PCCP water mains. *Page C-2.1.*  
\_\_\_ h. Easement for deep sewers. *Page C-2.2.*
- \_\_\_ 12. Pipe Protection.  
\_\_\_ a. Polyethylene encasement on all DIP mains. *Pages W-2.1 and S-3.1.*  
\_\_\_ b. For DIP sewers, special exterior lining. *Page S-3.1 and C-8.7.*  
\_\_\_ c. Ungrouted riprap, plan and profile (Standard Detail SC/3.0).  
\_\_\_ d. Erosion check (ground over pipe 20% or greater). Every fifteen (15) feet, show number required on profile Standard Detail M/3.0). *Page C-7.1.*  
\_\_\_ e. Concrete anchors for pipes. *Page C-14.1*  
\_\_\_ 1) 24" and smaller, anchors per Standard Detail M/4.0 shown on the drawings, ductile iron or AWWA C900 PVC noted on plan and profile. *Page C-14.1.*  
\_\_\_ 2) Larger than 24", special design, calculations and special detail required. *Page C-14.1.*  
\_\_\_ f. Encasement shown on plan and profile. *Page C-13.1.*  
\_\_\_ g. Special construction requirements for work performed in the vicinity of existing water/sewer mains. *Page C-3.16.*  
\_\_\_ h. Corrosion Control measures incorporated. *Page C-28.1.*  
\_\_\_ 1) Test station numbers provided by WSSC. Total number of test stations indicated on Sheet 1. *Page C-28.2.*  
\_\_\_ 2) Type of existing corrosion control measures indicated on plan at connections to existing pipe. *Page C-28.6 and W-9.3.*  
\_\_\_ i. Settlement indicators (Standard Detail M/7.0 and M/7.1). *Page C-26.18.*  
\_\_\_ j. Where water main is below or parallel to sewer, SHC or septic field, provide proper protection of water supply. *Pages C-3.1 thru C-3.14.*  
\_\_\_ k. Maintain minimum cover under streams for water and sewer pipelines. *Pages W-11.1, S-8.2 and C-9.3.*  
\_\_\_ l. Buoyancy of pipelines. *Page C-4.1.*
- \_\_\_ 13. Azimuth, Distance Ties and Bench Marks. *Page C-1.1 and Appendix D.*





- \_\_\_ a. Tie to each manhole, fitting, PC and PT, soil boring, test station, etc. *Pages C-1.1 and C-1.2.*
  - \_\_\_ b. Azimuth and distance between traverse stations shown. *Page C-1.1.*
  - \_\_\_ c. Traverse station ties shown. *Pages C-1.1 and C-1.2.*
  - \_\_\_ d. Curve data required. *Pages C-1.1 and C-1.2.*
  - \_\_\_ e. Required bench marks shown minimum 3 per sheet. (Iron pipes, manholes and fire hydrants not acceptable). *Page C-1.1.*
- \_\_\_ 14. Tunnel/bore-jack. *Page C-26.1 and Appendix F.*
- \_\_\_ a. Computations submitted to support the design, as required (non-standard items may require computations).
  - \_\_\_ b. Options given. *Page C-25.1.*
  - \_\_\_ c. Observation wells as required at tunnel borings. *Appendix F-1.*
  - \_\_\_ d. Final Tunnel Geotechnical Report, if required. *Pages C-20.1 and C-26.5.*
  - \_\_\_ e. Permit from issuing agency in conformance with design.
- \_\_\_ 15. Special Provisions to Specifications, if required.
- \_\_\_ a. Identify and submit technical information necessary to prepare Special Provisions and include Special Provisions in the Contract Documents. *Page C-6.1.*
- \_\_\_ 16. Hydrogen Sulfide Protection. *Pages S-24.11, S-25.6 and S-28.1.*
- \_\_\_ a. Protection for manholes/structures provided.
  - \_\_\_ b. Protection for pipe and/or coatings/linings provided.

### FINAL WATER

- \_\_\_ 1. Size main.
  - \_\_\_ a. Compare with profile. *Page W-8.3*
  - \_\_\_ b. Size/class in General Notes. *Page W-4.1 and W-8.3.*
- \_\_\_ 2. Dimensions.
  - \_\_\_ a. All fittings and fire hydrants tied in. *Pages C-1.1 and C-1.2.*
  - \_\_\_ b. Sufficient number to stakeout. *Pages C-1.1 and C-1.2.*
  - \_\_\_ c. Final ties to existing ends or NTA. *Page C-1.1.*
  - \_\_\_ d. Show nearest existing fire hydrant. *Page W-24.1.*
  - \_\_\_ e. Existing valves necessary for shutdown are located. *Page W-18.3.*
- \_\_\_ 3. Fittings.
  - \_\_\_ a. Labeled on plans. *Page W-8.2.*
  - \_\_\_ b. 100 foot stations shown on plans. *Page W-8.3.*
  - \_\_\_ c. Stations at fittings shown on plan for 16" water and larger. *Page W-8.2.*
  - \_\_\_ d. Labeled on profiles. *Pages W-8.3 and W-11.1.*
- \_\_\_ 4. Temporary water service required during construction *Pages W-10.1 and W-22.13 .*
- \_\_\_ 5. Water **Service** Connections *Page W-25.1.*
  - \_\_\_ a. WHC to each lot, parcel or building. *Page W-25.1.*
  - \_\_\_ b. Permit numbers shown. *Page W-25.1.*



- \_\_\_ c. WHC lowering at storm drains, ditches and other utilities. *Page W-25.5.*
- \_\_\_ d. Curb stop locations not in conflict with sidewalks or curbs. *Page W-25.4.*
- \_\_\_ e. Insulating joints at connections to existing water pipelines. *Page W-25.9.*
- \_\_\_ 6. Profiles.
- \_\_\_ a. Water profile proper depth (check structure requirements).  
*Pages W-4.1, W-11.2 and W-16.1.*
- \_\_\_ b. Stations in correct sequence.
- \_\_\_ c. Compares with plan length. *Page W-8.3.*
- \_\_\_ d. Fittings at intersections same elevation.
- \_\_\_ e. Fire hydrant lengths correct - submit tabulations. *Page W-24.1.*

### FINAL SEWER

- \_\_\_ 1. Size sewer line.
- \_\_\_ a. Compare with profile.
- \_\_\_ b. Compare with computations, if required.
- \_\_\_ c. Size and type in General Notes. *Page S-3.1.*
- \_\_\_ 2. Dimensions.
- \_\_\_ a. All manholes tied in. *Page C-1.2.*
- \_\_\_ 3. Sewer **Service** Connections.
- \_\_\_ a. Connection to each lot, parcel or building. *Page S-27.1.*
- \_\_\_ b. Permit numbers shown. *Page S-27.3.*
- \_\_\_ c. Connections from existing sewer in right of way, provide note "Not Included in Contract", if connection is not part of contract.
- \_\_\_ d. Note if normal service not being provided.
- \_\_\_ e. DHC'S shown, (minimum 8 feet deep at property line). *Page S-27.5.*
- \_\_\_ 4. Profiles.
- \_\_\_ a. Length compare with plan.
- \_\_\_ b. Sewer grades correct, submit tabulations if required.
- \_\_\_ c. Invert elevations correct, proper jump in inverts between different sizes. *Page S-17.1.*
- \_\_\_ d. Invert elevations at intersection coincide.
- \_\_\_ e. Rim elevations shown, submit tabulations. Verify rim elevations with other profiles.  
*Page S-11.2*
- \_\_\_ f. Existing, proposed or future grade lines shown, where required. *Page S-8.4.*
- \_\_\_ g. Sewer pipelines at stream crossings.
  - 1) DIP for smaller than 21-inch sewer pipelines and DIP or RCP for 21-inch and larger sewer pipelines with twelve (12) foot lengths. *Page S-8.2.*
  - 2) For RCP, label in profile and include in the general notes the pipe class required and minimum lay length of twelve (12) feet. *Page S-8.2.*
- \_\_\_ h. Sewer pipeline on steep grades, ten (10%) percent and greater. PVC AWWA C-900 for 12" and smaller and DIP or PVC AWWA C-905 for larger than 12". *Page S-15.3.*
- \_\_\_ i. Verify minimum slope requirements on Table 11. *Page S-9.1.*
- \_\_\_ j. DHC's shown, station and top elevation. *Page S-27.5*



- \_\_\_ k. Minimum grade 1% for terminal sewers. *Page S-9.1.*
- \_\_\_ 5. Manholes.
- \_\_\_ a. Manhole depths within Standard Details limitations. *Page S-18.1.*
- \_\_\_ b. Frame and cover set at proposed elevation shown on profile, one (1) foot above existing ground or at existing grade. *Pages S-11.2 and S-11.3.*
- \_\_\_ c. Shallow manhole specified on profile. *Page S-18.1.*
- \_\_\_ d. Manhole geometry, sufficient inside diameter for incoming and outgoing sewer pipelines. *Page S-14.1.*
- \_\_\_ e. Manhole drop connections labeled on plan and profile. *Page S-16.1.*
- \_\_\_ f. Pipe to manhole connection note for deep manholes. *Pages S-18.1.*
- \_\_\_ g. Pipe to manhole connection note for steep grades. *Pages S-14.5 and S-15.3.*
- \_\_\_ h. Special design for manholes over twenty four (24) feet deep. *Page S-18.1.*
- \_\_\_ i. Fall prevention systems for manholes over twenty (20) feet deep (minimum 60" diameter manhole) shown in profile. *Pages S-18.1 and S-20.1.*
- \_\_\_ j. 0.1 foot minimum channel drop at manholes. *Page S-17.1.*
- \_\_\_ k. Manhole rotation note. *Page S-11.1.*
- \_\_\_ l. Protective coatings for H<sub>2</sub>S control. *Pages S-24.6, S-25.5 and S-28.3.*
- \_\_\_ 6. Pressure Sewers (Grinder Pump Systems).
- \_\_\_ a. Calculations for sizing the pressure sewer lines have been prepared and approved. *Pages S-25.1 and S-25.2.*
- \_\_\_ b. Compare sizing of pipe diameters for PVC and HDPE. *Page 25.3.*
- \_\_\_ c. Compare size of pressure sewers for consistency between calculations, plans and profiles. *Page S-25.3.*
- \_\_\_ d. Thrust restraint. *Page S-25.3.*
- \_\_\_ e. Air/vacuum and air release valves provided at high points. Ideally, high points should be avoided. *Pages S-25.3 and S-25.4.*
- \_\_\_ f. Flushing connections every four hundred (400) ± feet and at dead ends. *Page S-25.4.*
- \_\_\_ g. Locator stations and tracer wire for directionally drilled HDPE pressure sewers. *Page 25.4.*
- \_\_\_ h. No ninety (90°) degree bends. *Page S-25.5.*
- \_\_\_ i. Minimum radius of curvature to be in accordance with design criteria. *Page S-25.5, Table "18".*
- \_\_\_ j. Transition manhole at pressure sewer connection to gravity system. *Page S-25.5.*
- \_\_\_ k. Verify cellar elevations on drawings are compatible with elevations of grinder pumps used in calculations. *Page 25.3.*
- \_\_\_ l. WHCs are not located in same trench with Pressure Sewer House Connections (ten (10) feet minimum horizontal clearance). *Pages S-25.5 and C-3.1.*
- \_\_\_ m. Pipe and manhole protection required for H<sub>2</sub>S corrosion and odor control downstream of discharge into gravity system. *Pages S-25.5 and S-25.6.*

Final Design Field Reviewed By

Title &amp; Date

Final Design Checked By

Title &amp; Date



## APPENDIX B

### WSSC Design Criteria for Water Distribution Systems

#### a. System Requirements

##### 1) Pressure Requirements

- a) The water distribution system shall have adequate capacity to supply “domestic” demand to all customers -- residential, public, commercial, and industrial -- while maintaining the following minimum pressures.
  - 40 psi at the maximum-day demand flow rate
  - 20 psi at the sum of the maximum-day demand flow rate and the appropriate fire flow rate or, if greater, at the peak hour demand flow rate.
- b) Maximum-day demand conditions are represented by the low hydraulic grade for an area. Exceptions to the maximum-day flow rate pressure are permitted in small areas where it is not feasible to provide service from a higher pressure zone or not reasonable to create a new zone.
- c) Where the pressure at a connection during the maximum-day demand flow rate is between 25 and 40 psi, either a booster pump can be installed by the building owner or the house connection and plumbing design can be enlarged to meet pressures required in Plumbing Code. Where the pressure at the connection during the maximum-day demand flow rate is between 20 and 25 psi, the installation of booster pumps by the building owner will be required.
- d) The high hydraulic grade represents system conditions with minimal demand. Connections with more than 80 psi during high hydraulic grade conditions will be required to be fitted with an individual pressure reducing valve as described in Plumbing Code.
- e) The water distribution system should be designed to provide domestic pressures generally no higher than 115 psi and not to exceed 130 psi based on the high hydraulic grade.

##### 2) Domestic Demand Requirements: Unless more specific information is available, the following criteria will be used in estimating water demand.

###### a) Average Demand Flow Rate

- (1) The average demand flow rate can be estimated by using the following current water production factors:

Single-family Dwelling Unit (SFDU)	228 gpd/unit
Multi-family Dwelling Unit (MFDU)	181 gpd/unit
Employment	56 gpd/employee

- (2) Other demand factors can be estimated from the base sanitary flow numbers (see Appendix C of the Sewer Design Guidelines).



## b) Maximum-Day Demand Flow Rate

- (1) The maximum-day demand flow rate can be estimated by multiplying the average demand flow rate by the maximum-day factor. The current maximum-day factor for determining the size of service mains is 2.0.

## c) Peak Hour Demand Flow Rate

- (1) The peak hour demand rate is not normally used for design unless directed by WSSC. Use either one (1) of the following:
  - (a) Peak hour flow is to be two (2) times the maximum-day flow.
  - (b) Peak hour factor provided by WSSC.

## 3) Fire-Flow Rate Requirements

- a) A minimum fire-flow rate of 1,000 gallons per minute should be available with a residual pressure of at least 20 psi at all WSSC system fire hydrants during maximum-day demand conditions.
- b) For hydrants in areas with attached housing and **non-residential lands uses** should have **1,000 gpm must be** available at the last, most hydraulically remote hydrant with an additional 500 gpm fire flow available simultaneously at an adjacent hydrant during maximum-day demand conditions.
- c) The minimum fire-flow rate for **non-residential properties** is **1,500 gpm** during maximum-day demand conditions between two adjacent hydrants, as described above for attached housing. Fire protection in excess of 1,500 gpm shall be provided as called for by the Prince George's County and the Montgomery County Fire Marshals, and may require **additional** onsite storage and/or pumping.

**b. Hydraulic Design Criteria**

- 1) Demand used in hydraulic modeling to determine water main sizing shall be the greater of maximum-day demand flow rate plus the appropriate fire-flow rate or the peak hour demand.

Example: (Determining Demands)

Proposed development consists of 512 apartments and 27,500 square feet of office space. Since the number of employees is unknown, the base sanitary sewage flow factor for office use can be used to estimate the average water demand. The base sanitary flow factor for offices is currently 0.093 gpd per square foot of office space. (See Appendix C, WSSC Design Criteria for Sewer Systems)

Proposed Development	Average Demand (gpd)	Maximum-Day Demand (mgd)	Peak-Hour Demand (mgd)
512 apartments	61,952	0.12	0.24
27,500 sf office	2,558	0.01	0.01
Total	64,100	0.13	0.25



The fire flow demand requirement of 1,500 gpm (or 2.16 mgd) would apply for this development. The maximum-day demand plus fire flow would be 2.29 mgd. This rate is greater than the peak-hour demand of 0.25 mgd. Therefore, maximum-day demand plus fire flow should be used when modeling for this subdivision.

- 2) In addition to the domestic demand, pressure and fire-flow demand requirements, the hydraulic design should take into account pipe sizes, length, and roughness. The ability of a pipe network, instead of a single feed, to convey water should be considered in many cases to avoid over-sizing mains. The proposed system should also take into account the ability to accommodate future planned development. Finally, when large-diameter mains or long extensions to serve a relatively small demand are proposed, the travel time between a point with acceptable chlorine-residual levels to the most remote connection point will be evaluated.
- 3) Water mains should be sized to limit the friction headloss in the distribution system. The calculations should show that the highest and most hydraulically remote fire hydrant(s) will maintain the required design conditions. The Hazen-Williams formula should be used for calculating head loss in pipes during fire flow conditions.

$$\text{Head Loss} = \frac{1,905,872 * L * Q^{1.85}}{C^{1.85} * D^{4.87}}$$

In the version shown above, the head loss and the pipe length (L) are feet, the demand (Q) is in million gallons per day and the pipe diameter (D) is in inches. The Hazen-Williams "C" value © is unitless.

#### 4) Estimating Maximum-Day Demand

- a) Where specific land uses are known, maximum-day demand will be estimated using the method described herein.
- b) Where specific land uses are not known, the maximum-day demand rate in existing mains, and future areas of fewer than 100 acres, can be estimated by a flow that would be equivalent to the flow that would cause a head loss of 1 foot through a 1000-foot long pipe with design "C" values. The following table shows the flow causing headloss of 1'/1000' for common pipe diameters.

**TABLE "8"**

Guidelines for Estimating Maximum-Day Demand in Existing Mains

Pipe Diameter (inches)	Flow which would cause 1' of head loss through a 1000' length of pipe (mgd)
6	0.11
8	0.23
10	0.45
12	0.73
14	1.20
16	1.71
20	3.07
24	5.37



## 5) Roughness

- a) While new pipes tend to have relatively high "C" values, hydraulic design should take into consideration the future conditions of proposed pipelines. Use the Hazen-Williams "C" values shown below for factory-lined pipes built during or after the years shown in Table "9a".
- b) Mains that were installed before the years shown in Table "9a" were not factory lined. Many of these mains originally installed without a lining have been cleaned and lined. It can be assumed that these mains have the "C" values shown in Table "9a" unless it is known that they have been lined, or that a smaller C value is warranted.

**TABLE "9a"**

Hazen-Williams "C" Coefficients for Lined Pipes

Pipe Diameter (inches)	Built Since	Hazen-Williams "C" Coefficient
4 - 8	1965	100
10	1952	110
12	1946	110
16 - 20	1946	120
24 and greater	1946	130

- c) Unlined pipes are often tuberculated. Not only is the effective diameter of the pipe reduced, the roughness of the inside surface of the pipe is increased. The net effect is much greater head loss than would be expected in lined pipe. When possible, field tests should be run to either verify the condition of the unlined mains or the ability of the existing system to convey flows. When field tests are unavailable, "C" values of the unlined pipe can be approximated (see Table "9b" at the end of this Appendix).
- d) Example of modeling with reduced "C" values.

Beginning fire hydraulic grade = 348 feet

Calculate head losses in pipes between the fire hydraulic grade and the study point:

Length (feet)	Diameter (inches)	"C" value	Fire Flow (mgd)	Domestic (mgd)	Total Flow (mgd)	Head Losses (feet)
1400	12	110	1.44	0.74	2.18	10
500	8	46	1.44	0.01	1.45	64
500	8	100	1.44	0.01	1.45	15
Total Head Losses						89

Beginning Fire Hydraulic Grade            348 feet  
 Head Losses                                        - 89  
 Fire Grade at study point                    259 feet  
 Residual pressure at the study point needs to be 20 psi or greater

Fire Grade at study point                    259 feet  
 Elevation at study point                    -187  
 Pressure at the study point                 72 feet

Convert feet to psi: 72 feet / 2.31 feet/psi = 31 psi



6) Pipe Diameter

- a) The minimum size for a WSSC main is 4 inches in diameter. (4-inch mains in the pipe network should be excluded.)
- b) Fire hydrant should not be located on 6-inch and smaller water mains.
- c) No connections to existing Water Transmission Mains (30-inches and larger) except as noted in Part 1, Section 9 under Limitation of connections to Existing Pipelines.

7) Starting Point

- a) Modeling calculations will begin at one or more nodes and use the fire hydraulic grade at that point. The fire hydraulic grades represent the hydraulic grade with maximum-day demand and a fire flow rate at that particular point in the system. These fire hydraulic grades are prepared by the Planning Group.

8) Effect of the Pipe Network

- a) Designs that use more than one feed into an area usually result in fewer head losses and, therefore, would result in smallest pipe diameters needed for the proposed project.

Example & Modeling of a simple pipe network.

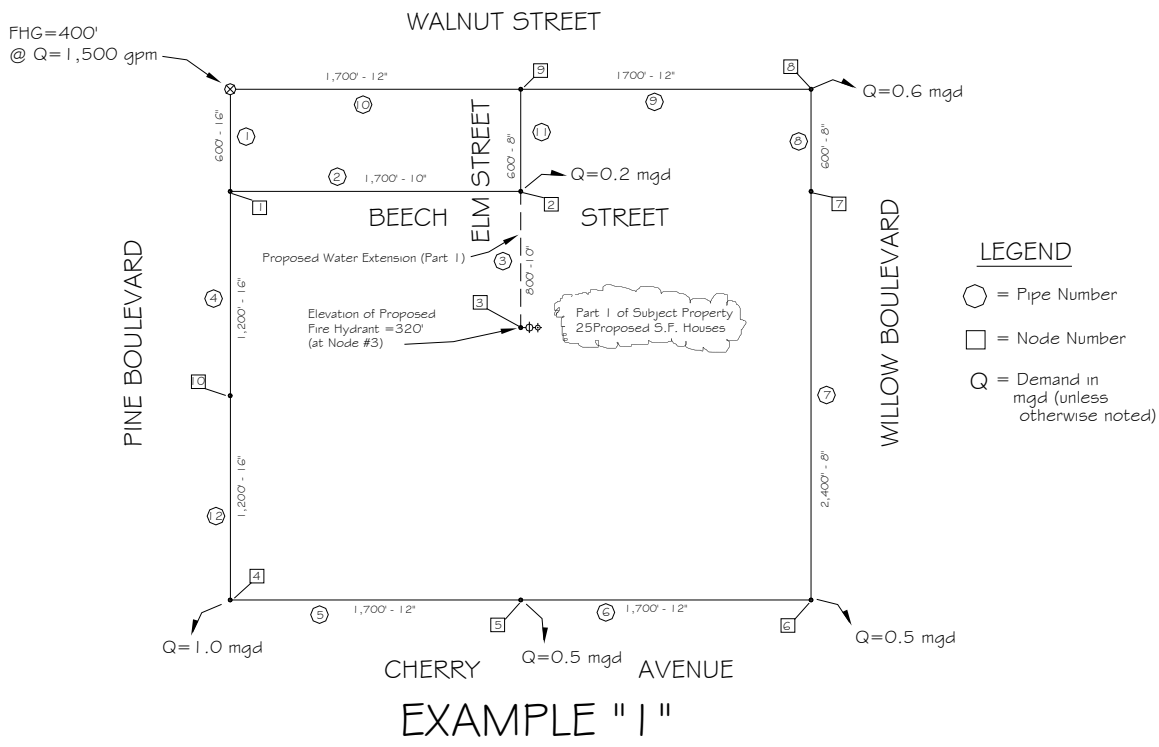

In the example shown, the proposed water extension is initially sized as a 10" W line. The proposed fire hydrant at node #3 is initially served by a "single feed" through pipes #1, #2, and





#3. For a demand of 1.46 mgd (1.44 mgd fire flow and 0.02 mgd maximum day domestic demand) at node #3, the proposed water extension (pipe #3) is sized as 10" W, and the resulting pressure at the fire hydrant at node #3 is 22.78 psi.

However, in Change Situation #1, a "networking" effect is achieved by including pipe #11 in the water network so that a "2nd Feed" to the proposed water extension is provided. With pipe #11 included in the network, the proposed water extension (pipe #3) can be down-sized to 8"W. The resulting pressure with 1.46 mgd of water flow to the proposed fire hydrant at node #3 is 20.32 psi, which is adequate water pressure, as well.

9) Dependencies

- a) When a subdivision is built in more than one phase, it must be demonstrated that the system requirements will be met throughout build out of the subdivision. Should one phase of the subdivision be dependent on other(s) in order to meet the system requirements, the dependency should be noted in the hydraulic calculations.

Example of a part dependency.

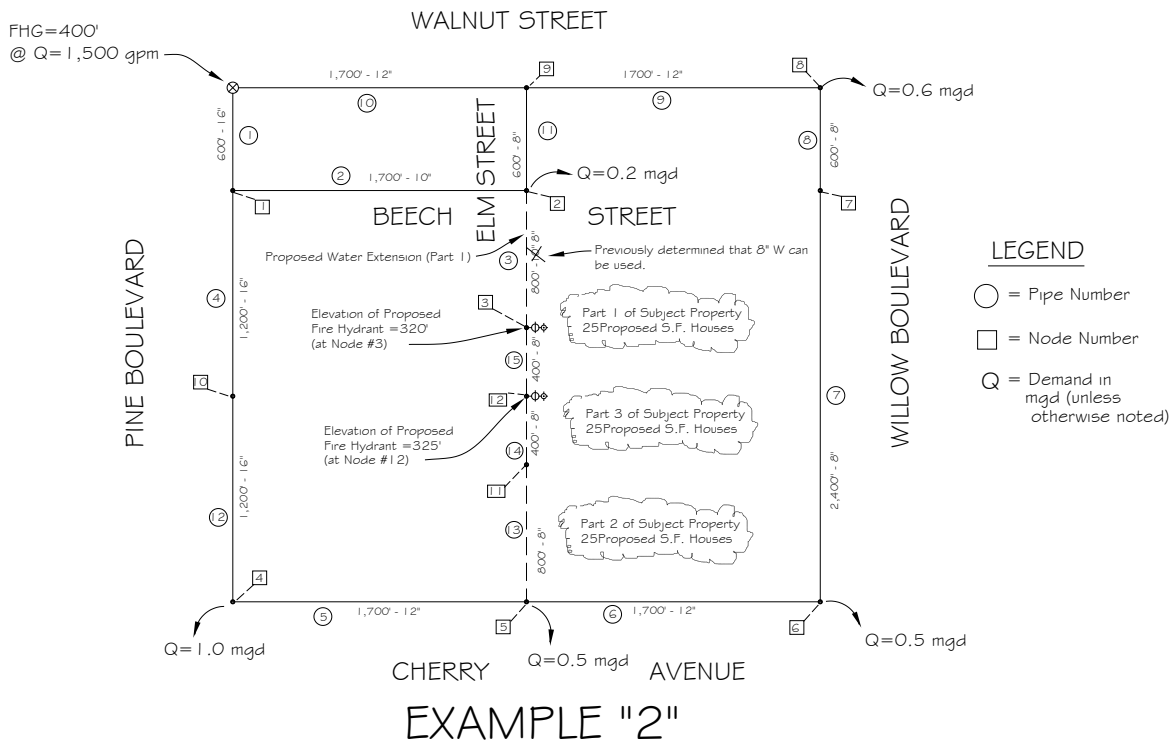

In the example shown (see sketch), there is a small proposed 3-part subdivision. Pipe #3 passes through and will be built under Part #1. Pipe #13 passes through and will build under Part #2. Pipes #14 and #15 pass through and will be built under Part #3, and will provide flow to the proposed fire hydrant at node #12 (which will provide fire protection to Part #3).

Because of the way this proposed subdivision is set up, the question must be answered as to whether Part 3 can be dependent on Part 1 only, Part 2 only, or if Part 3 is dependent on



BOTH Part 1 and Part 2, together.

First, check if Part 3 can be solely dependent on pipe #3 in Part 1. If pipe #13 in Part 2 is closed, and 1.46 mgd is pulled from node #12 (i.e. a proposed fire hydrant serving Part 3), the resulting pressure at node #12 is 12.88 psi, resulting in sub-standard fire flow pressure.

Similarly, check if Part 3 can be solely dependent on pipe #13 in Part 2. If pipe #3 in Part 1 is closed, and 1.46 mgd is pull from node #12, the resulting pressure at node #12 is 9.88 psi, again resulting in sub-standard fire flow pressure.

Last, determine if Part 3 can be obtain adequate fire flows & pressures with dependencies on both Part 1 and Part 2. If pipe #3 and pipe #13 are both opened, and 1.46 mgd of flow is pulled from proposed fire hydrant at node #12, the resulting pressure at node #12 is 25.05 psi, which is adequate pressure by WSSC standards.

#### 10) Service Zone Concerns

- a) Subdivisions located near a pressure zone boundary may be served by more than one zone. To determine which zone would better serve a particular main, the range of domestic pressures that would be provided from each zone should be compared. The high domestic pressure should not exceed 115 psi and is limited to 130 psi. The low domestic pressure should not be less than 40 psi. While the lower zone's domestic pressures may appear to be more than acceptable, sometimes the fire flow requirements cannot be met. If either zone appears appropriate, a determination should be made regarding the best way to serve the surrounding area. Specialty valves (i.e., pressure reducing valves, pressure relief valves) may be required in these areas.

#### 11) Minor Losses

- a) To minimize minor losses in distribution mains, the layout should be adjusted whenever possible to avoid bends greater than 40° in mains 12 inches in diameter and larger.

#### 12) Travel Times

- a) When a relatively large volume of water is available to serve a small demand, long travel times can result. Excessive travel times can be expected in Capital Improvement Program (CIP) sized mains during the early phases of a subdivision build out, but can also be found in long extensions of smaller mains serving only a few dwellings. Water that sits too long tends to lose its chlorine residual and has the potential to experience bacterial regrowth. Since chlorine dissipation time varies based on a number of uncontrollable variables (e.g., temperature, age of the pipe), there are currently no hard rules as to how long water can sit before it becomes unpotable.
- b) Travel times should be estimated and, where calculations show the travel times to be 14 days or more, a mitigating solution to the excessive travel times is required.
- c) Delaying the construction of distribution mains might be a solution for some long travel-time situations. The WSSC will determine whether a service main -- rather than a distribution main -- could be economically constructed based on Maryland National Capital Park and Planning Commission (MNCP&PC) population projections. A present worth analysis might be initiated to see if it is worthwhile to have a service main built for the current service



request knowing that it will be replaced later with a distribution main when the demand increases.

13) Considerations for Future Service

- a) Hydraulic calculations should assume that in areas zoned for apartments and non-residential land uses there will be private site utility system (on-site) served off the proposed extensions. The proposed mains might also have to serve additional future development and this possibility should also be taken into consideration.
- b) Future Private Site Utility System (on-site)
  - (1) Other Future Subdivisions: Every extension needs to be adequately sized to handle future development. The following can be consulted for information about future development: facility plans, zoning maps, land use maps, and service area category maps. Other references that are useful for this effort are topographic maps and non-tidal wetland maps.
  - (2) It should be realized that multi-family and non-residential development tying into the current extension are likely to have an on-site systems with fire hydrants. These private site utility system (on-site) hydrants will also be required to meet the fire flow requirements shown in section above. Allowances for losses within the private site utility system (on-site) must be made. It may be necessary to assume alignments for those private site utility systems (on-site) if they have not yet been designed.

Example of planning for future development.

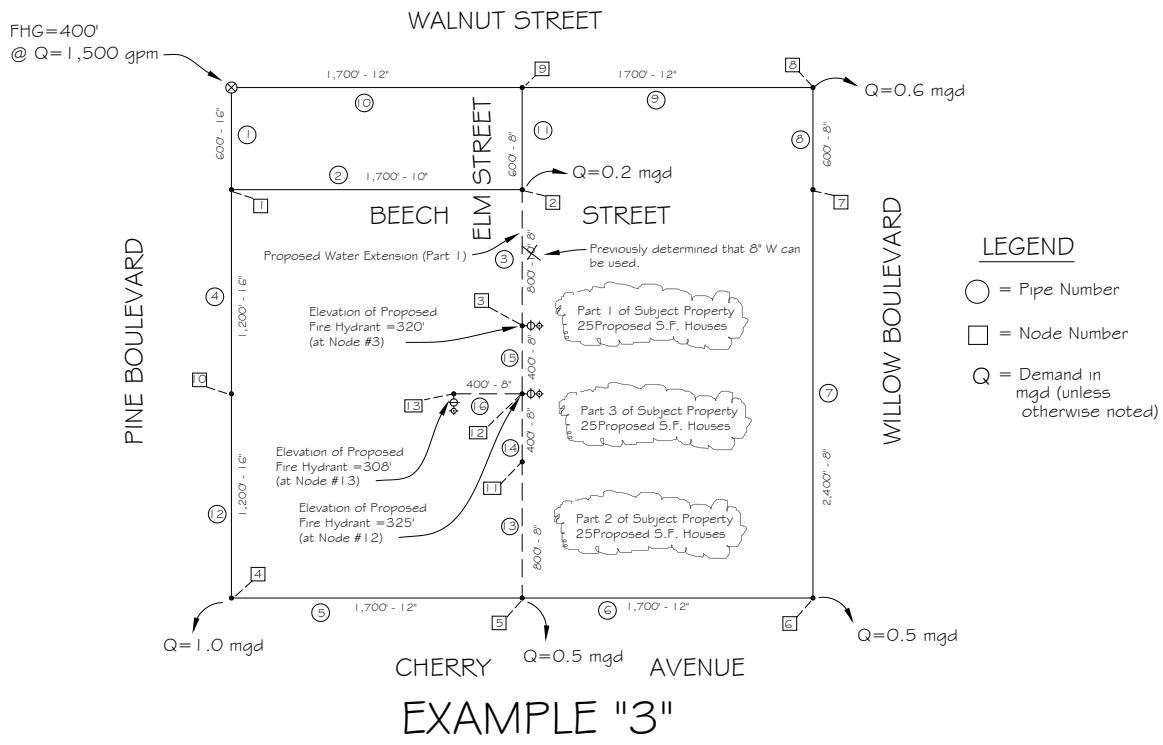

Water lines must be sized to adequately serve NOT ONLY the current subject property, but also other adjacent properties that may be developed and served in the future. In the previous examples, it was determined that single-family houses in Part #1, Part #2, and Part #3 can adequately be served using 8-inch for proposed water lines. However, consideration must be given as to whether a future, adjacent subdivision composed of 60 proposed townhouses can adequately be served using 8-inch water in Parts #1, #2, and #3.

If all 8-inch water is used in Parts #1, #2, and #3, and 8-inch water is also used to serve the future townhouses, and 2.18 mgd of flow is pulled from the proposed fire hydrant at node #13 that serves the townhouses, the resulting pressure at node #13 is 15.14 psi, which is sub-standard pressure.

However, if 2 water lines (pipe #13 in Part 2 and pipe #14 in Part 3) are UP-SIZED to 12-inch, and 2.18 mgd is again pulled from node #13, the resulting pressure at the proposed future fire hydrant serving the future townhouses is 20.54 psi, which is adequate pressure by WSSC standards.

In order to satisfy BOTH conditions of providing adequate service to the current proposed property composed of 3 parts, as well as the anticipated future development composed of 60 townhouses, we must size pipes #3 and #15 as 8-inch water, and size pipes #13 and #14 as 12-inch water. The future water extension (pipe #16) will be sized as 8-inch water when the future development is submitted to WSSC for review.

### c. Non-Hydraulic Alignment Considerations

- 1) Often there are factors other than adequate hydraulics that will affect the layout and sizes of a portion of the water distribution system.
  - a) Future Service
    - (1) Rights-of-way and construction strips necessary for future extensions should be granted to the WSSC. For extensions, size should be determined to allow for adequate rights of way and when necessary, adequately sized stubs.
  - b) Large-diameter Mains
    - (1) Intersecting large-diameter mains: So that relocating distribution and transmission mains is not necessary, the layout should avoid crossing these mains whenever possible.
- 2) Acquisition of Additional Rights-of-Way
  - a) If water **transmission** mains 16-inch and larger diameter exist on a parcel to be developed, acquisition of additional rights-of-way for operation and maintenance of the **transmission** main may be necessary. Many existing transmission mains do not have adequate rights-of-way to repair the main, see Part Three (Common), Section 2 (Rights of Way and Construction Strips).



### 3) Looping and Valve Policy

- a) Looping, as well as conscientious placement of valves, improves the reliability of the entire water distribution system. The policy was created for two reasons:
  - 1) Minimize outages during periods when mains are out of service.
  - 2) Discourage poor water quality by minimizing dead-end mains. After determining the mains required for service, the layout should be evaluated against the Looping and Valve Policy outlined below.
- b) **Looping requirement for connection to existing Water Transmission Mains (30-inches and larger), Part 1, Section 9 under Limitation of connections to Existing Pipelines.**
- c) **Outage-Protection Loops.**
  - (1) An outage-protection loop is a loop that is not required in order to provide adequate pressures for required flows under normal circumstances. An outage-protection loop is intended to provide an additional feed during a break in the principal feed to an area.
  - (2) Outage-protection loops should be sized large enough so that during a main break normal domestic pressures can be achieved with either 1) the maximum-day demand flow rate when the loop is 12 inches in diameter or smaller or 2) the average-day demand flow rate when the loop is 16 inches in diameter and larger.
- d) **System-Improvement Loops**
  - (1) A system-improvement loop is not required to serve the current area at hand, but to improve the existing system, to either bring it up to design standards or otherwise improve pressures in an area in order to meet design standards in the future.
- e) **System Improvements**
  - (1) On occasion, a portion of main being designed to serve a subdivision will have to be larger than that needed to serve the new subdivision alone. These system improvements are usually necessary to be able to serve future development in the area or to complete a portion of a future distribution main. Sometimes system improvements are needed to correct or avoid substandard conditions.



**TABLE "9b"**  
Estimating "C" Coefficients in Unlined Mains

Years Old	Diameter (inches)										
	4	6	8	10	12	14	16	20	24	30	36
100	0	5	13	21	28	34	38	45	50	55	59
99	0	5	14	22	28	34	38	45	50	56	59
98	0	5	14	22	29	34	39	46	51	56	60
97	0	5	14	22	29	35	39	46	51	56	60
96	0	6	15	23	30	35	39	46	51	56	60
95	0	6	15	23	30	35	40	47	51	57	60
94	0	6	15	23	30	36	40	47	52	57	61
93	0	7	16	24	31	36	41	47	52	57	61
92	0	7	16	24	31	37	41	48	52	57	61
91	0	7	17	25	32	37	41	48	53	58	61
90	0	7	17	25	32	37	42	48	53	58	61
89	0	8	17	25	32	38	42	49	53	58	62
88	0	8	18	26	33	38	42	49	54	58	62
87	0	8	18	26	33	38	43	49	54	59	62
86	1	9	19	27	34	39	43	50	54	59	62
85	1	9	19	27	34	39	44	50	54	59	63
84	1	10	19	28	34	40	44	50	55	59	63
83	1	10	20	28	35	40	44	51	55	60	63
82	1	10	20	28	35	41	45	51	55	60	63
81	1	11	21	29	36	41	45	51	56	60	64
80	1	11	21	29	36	41	45	52	56	61	64
79	1	11	22	30	37	42	46	52	56	61	64
78	2	12	22	30	37	42	46	52	57	61	64
77	2	12	23	31	38	43	47	53	57	61	65
76	2	13	23	31	38	43	47	53	57	62	65
75	2	13	24	32	39	44	48	53	58	62	65
74	2	14	24	32	39	44	48	54	58	62	65
73	3	14	25	33	40	44	48	54	58	63	66
72	3	15	25	33	40	45	49	55	59	63	66
71	3	15	26	34	41	45	49	55	59	63	66
70	4	16	26	34	41	46	50	55	59	64	66
69	4	16	27	35	42	46	50	56	60	64	67
68	4	17	27	35	42	47	51	56	60	64	67
67	5	17	28	36	43	47	51	57	60	65	67
66	5	18	28	36	43	48	52	57	61	65	68
65	5	18	29	37	44	48	52	57	61	65	68
64	6	19	30	37	44	49	52	58	62	66	68
63	6	20	30	38	45	49	53	58	62	66	69
62	7	20	31	38	45	50	53	59	62	66	69
61	7	21	31	39	46	50	54	59	63	67	69
60	7	21	32	40	47	51	54	60	63	67	70
59	8	22	33	40	47	52	55	60	64	67	70
58	8	23	33	41	48	52	56	61	64	68	70
57	9	23	34	41	48	53	56	61	65	68	71
56	10	24	34	42	49	53	57	62	65	68	71
55	10	25	35	42	50	54	57	62	65	69	71
54	11	25	36	43	50	54	58	63	66	69	72
53	11	26	36	44	51	55	58	63	66	70	72



Years Old	Diameter (inches)										
	4	6	8	10	12	14	16	20	24	30	36
52	12	27	37	44							
51	13	28	38	45							
50	13	28	39	46							
49	14	29	39	46							
48	15	30	40	47							
47	16	31	41	48							
46	17	32	42								
45	17	32	42								
44	18	33	43								
43	19	34	44								
42	20	35	45								
41	21	36	46								
40	22	37	46								

Notes:

1. The above estimates are to some extent based on WSSC field tests and a review of literature. It is important to note that C values may vary considerably for pipes of the same age and material.
2. The above "C" values were calculated as follows, for 12" and larger mains built before 1946 where a year represents the age of the pipe:

$$C = \left[ \left\{ 50(0.9319^{years}) + 80 \right\}^{1.85} \left\{ \frac{Diameter - 0.039774 * years}{Diameter} \right\}^{4.87} \right]^{1/1.85}$$

3. For 10" mains built before 1952 and 4"-8" mains before 1965, where a year represents the age of the pipe:

$$C = \left[ \left\{ 50(0.9552^{years}) + 80 \right\}^{1.85} \left\{ \frac{Diameter - 0.039774 * years}{Diameter} \right\}^{4.87} \right]^{1/1.85}$$



## APPENDIX C

### WSSC Design Criteria for Sewer Systems

#### a. System Requirements

##### 1) General

- a) Design the flow capacity of sewers and the flow through the associated manholes and junction structures (especially for trunk sewers) to convey the ultimate flow within the area tributary to the sewer, unless WSSC determines that a lesser requirement is suitable.
- b) Determine wastewater flow from the tributary area based upon development plans and the most current master plan information.
  - (1) **Current and Master Planning Information** can be obtained by accessing the Maryland-National Capital Park and Planning Commission's web site.
  - (2) Sewer service in master planning areas is determined by the corresponding County Ten-Year Water and Sewerage Plan. In order to obtain public sewer service from WSSC, the property or area in question must be in the appropriate service category for sewer service. Otherwise, an applicant/property owner must petition the appropriate county to approve, amend, and/or change the property's sewer category for public service. Private systems (those not connecting to the WSSC system, with the exception of private site utility system (on-site) private sewer mains serving commercial and some large residential properties in the WSSC service area) are regulated and approved by the appropriate County.
- c) Whenever feasible, design sewers to function by means of open channel gravity flow. Wastewater pumping stations, force mains, grinder pump systems, and pressure sewers may be used only when deemed appropriate and approved by WSSC.
  - (1) Grinder pump systems must meet standards by the *WSSC Grinder Systems Policy and Guidelines* (WSSC SP ENG 04-10, approved January 26, 2005). See Part Two, Section 25 (Grinder Pump, Pressure Sewer System) for design guideline.
  - (2) Wastewater Pumping Stations (WWPS) and force mains must meet design guidelines set by those in the WSSC Design Manual (DG-07& DG-08).
  - (3) The design flow for a WWPS is based on the amount of flow projected in 20 years, rather than the flows from ultimate build out of the area.

##### 2) Flows

- a) Design the sewers to have a scour velocity of 2.5 ft/sec at half flow capacity, see Table "19" for minimum slope of sewer pipes.
  - (1) Size the sewers to convey the design flow (DF) (as derived in 3-d) and determine the sewer capacity using Manning's equation with  $n = 0.013$  and the slope of the sewer.





- (2) Ensure, where practical, that the proposed design will attain scouring velocities at the initial peak flow condition at the beginning of the design period. Where this is not practical, present calculations to WSSC demonstrating that it is impractical and describing how the proposed design will address deposition of solids and the generation of hydrogen sulfide.
- (3) Design sewers with some reserve capacity. This will ensure the functionality of the design and allow for future reductions in conveyance efficiencies, possible increases in infiltration/inflow (I/I), unanticipated maintenance problems, and limited land use/development changes. The reserve capacity will be attained by use of a factor of safety as shown in 3-d below.
- b) Give consideration to the potential for hydrogen sulfide generation and release as result of the proposed design. Design the sewer systems to minimize the production and release of hydrogen sulfide in the sewer lines, see the Part Two, Section 28 (Hydrogen Sulfide (H<sub>2</sub>S) Control) for design considerations.

**TABLE "19"**  
Minimum Slope of Sewer Pipelines

Sewer Diameters	Minimum Slope	Capacity at Minimum Slope	Sewer Diameters	Minimum Slope	Capacity at Minimum Slope
8-inch	0.60%	0.60 mgd	21-inch	0.14%	3.80 mgd
10-inch	0.46%	0.95 mgd	24-inch	0.12%	5.00 mgd
12-inch	0.34%	1.32 mgd	27-inch	0.11%	6.60 mgd
15-inch	0.24%	2.02 mgd	30-inch	0.10%	8.50 mgd
18-inch	0.19%	3.00 mgd	36-inch	0.07%	10.60 mgd



**b. Determining Flows**

## 1) Design Flows (DF).

- a) Design the sewers to convey the Design Flow (DF) that will originate from the area tributary to the sewer.
- b) Estimate the design Base Sanitary Flow (BSF) for specific development using the factors in Tables "19a", "19b" and "19c".

DU= Dwelling Unit

**TABLE "19a"**

Development Flow Factors – By Dwelling Type

By Dwelling Type	BSF/DU (gpd)	AWF/DU (gpd)
Single-family Detached	190	280
Townhouses	140	215
SFDU (composite)	175	260
Garden Apartments	100	150
High-Rise Apartments	100	150
MFDU (composite)	100	150
Household (composite)	160	240

DU= Dwelling Unit

**TABLE "19b"**

Development Flow Factors – By Employee Type

By Employment Type	BSF/Employee (gpd)	AWF/Employee (gpd)
Bi-county (WSSD)	32	50



**TABLE "19c"**  
Development Flow Factors – By Specific Use

By Specific Use	Unit	BSF/Unit (gpd)	AWF/Unit (gpd)
Airport	passenger	5	7.2
Assembly Halls	seat	2	2.88
Auto Dealerships	gross sq. ft.	0.078	0.112
Bakery	gross sq. ft.	0.15	0.216
Banks	gross sq. ft.	0.044	0.063
Barber Shop	gross sq. ft.	0.20	0.288
Car Wash without recycle	gross sq. ft.	4.9	7.056
Carry-out – except major chains	gross sq. ft.	0.20	0.288
Carry-out – major chain	number of seats	10	14.4
Church	number of seats	4	5.76
Dept. Store without lunch counter	gross sq. ft.	0.04	0.057
Dept. Store with lunch counter	gross sq. ft.	0.08	0.115
Drug Stores	gross sq. ft.	0.13	0.187
Dry Goods Stores	gross sq. ft.	0.048	0.069
Garage (auto & truck repair)	gross sq. ft.	0.014	0.02
Hospitals	number of beds	346	498
Hotels	gross sq. ft.	0.256	0.368
Laundries & Cleaners	gross sq. ft.	0.31	0.446
Laundromats	gross sq. ft.	3.68	5.29
Laboratory/Office Facilities	gross sq. ft.	0.167	0.24
Library	gross sq. ft.	0.10	0.144
Medical Office Building	gross sq. ft.	0.62	0.892
Motels	gross sq. ft.	0.224	0.322
Nursing Homes	number of beds	130	187
Office Building in CDB/Transit Area	gross sq. ft.	0.20	0.288
Office Building	gross sq. ft.	0.093	0.133
Pool without hot showers	number of members	4	5.76
Pool with hot showers	number of members	6	8.64
Racket or Tennis Club	number of courts	300	432
Restaurants	number of seats	24.2	34.8
Retail Stores	gross sq. ft.	0.048	0.069
Schools, Elementary	capita	15	21.6
Schools, Middle	capita	20	28.8
Schools, High	capita	25	36
Shopping Centers	gross sq. ft.	0.172	0.247
Service Stations	gross sq. ft.	0.18	0.259
Supermarkets	gross sq. ft.	0.20	0.288
Theaters	number of seats	1	1.44
Warehouses	gross sq. ft.	0.021	0.03



## 2) Type of Flows.

- a) Base Sanitary Flow (BSF). **Wastewater** flow that is expected to be returned by the customer to the wastewater collection system.
- b) Average Wastewater Flow (AWF). Base sanitary flow plus an allowance for infiltration and inflow. The current “Sewage Flow Factor Analysis” calculates the AWF using the following equation.

$$\text{AWF} = 1.44 \times \text{BSF}^{**}$$

\*\* The equation shown above shall be used to provide a minimum allowance for infiltration and inflow. Additional allowance for infiltration and inflow may be made upon verification of evidence or approval of operational data or flow measurement.

- c) Peak Wastewater Flow (PWF). Is used to evaluate available capacity in existing sewers as well as a step in determining the Design Flow for new sewers. The Maryland Peaking Equation (See page 1-7 “Design Guidelines for Sewerage Facilities”, Technical Bulletin M-DM HH-EHA-S-001, 1978, Environmental Health Administration, Department of Health and State of Maryland) is used to calculate the PWF as follows:

$$\text{PWF} = (4 * \text{AWF}), \quad \text{where the AWF} \leq 0.25 \text{ mgd}$$

$$\text{PWF} = [3.2 * (\text{AWF})^{5/6}] \quad \text{where the } 0.25 \text{ mgd} < \text{AWF} \leq 16 \text{ mgd}$$

$$\text{PWF} = (2 * \text{AWF}) \quad \text{where the AWF} > 16 \text{ mgd}$$

The middle equation shown above **must** be in units of million gallons per day.

- d) Design Flow (DF). Is used to design new sewers. It includes the Peak Wastewater Flow, the reserve capacity which will be attained by a factor of safety to cover any future land use changes, plus a pool flow if applicable. The Pool Flow allowance is currently 0.1 mgd to cover the surge in flow when swimming pool filters are backwashed. The Pool Flow should be omitted **when** no swimming pools are located upstream from the sewer. Where two or more pools are located upstream of the sewer, it should be assumed that only one pool would be backwashed at any time. This flow should be added to DF if applicable. For peak wastewater flows greater than 3.75 MGD but less than 5.11 MGD, the design flow calculated from the 4<sup>th</sup> equation below would be less than it would be for lower peak wastewater flows. This may lead to constrictions in planned sewers when the results indicate that downstream capacities or sewer diameters should be less than the upstream capacities or diameters, To prevent this from happening, DF is kept at 5.63 mgd, if peak flow is between 3.75 mgd and 5.11 mgd. Design Flow should be calculated using following equations.

$$\text{DF} = \text{PWF} * \text{Factor of Safety} + 0.1 \text{ mgd of pool flow if applicable}$$

$$\text{DF} = (\text{PWF} * 1.5) + 0.1 \text{ mgd of pool flow if applicable when PWF} \leq 3.75 \text{ mgd}$$

$$\text{DF} = 5.63 \text{ MGD} + 0.1 \text{ mgd of pool flow if applicable when } 3.75 \text{ MGD} < \text{PWF} < 5.11 \text{ MGD}$$

$$\text{DF} = (\text{PWF} * 1.1) + 0.1 \text{ mgd of pool flow if applicable when PWF} \geq 5.11$$



3) Determining Existing Flow Existing flow is needed to calculate total flow.

$$\text{Total BSF} = \text{Existing BSF} + \text{Future BSF}$$

$$\text{Total AWF} = \text{Existing AWF} + \text{Future AWF}$$

- a) Existing Base Sanitary Flow can be estimated by the water usage report called "SM039". The SM039 report shows water usage by minibasin, and within each minibasin, breaks down the usage by development. The daily average consumption (DAC) is a weighted average and computed based on the customer's meter readings. The April DAC best represents the BSF. For the April report the maximum influence would have been exerted by actual water consumption during December, January, and February. All of these are months in which the consumptive losses are expected to be at their minimum.

For small residential areas, the existing flow can be estimated by counting the parcels upstream from a limiting capacity pipe and calculating the base sanitary flow.

- b) Average Wastewater Flow for large areas can be measured, when required, by flow monitoring.
- c) Once total AWF is calculated, DF can be derived using peaking factors, and factor of safety as described above.

### c. Hydraulic Design

1) Gravity Flow:

- a) Sewer size/capacity shall be determined using Manning's equation and with "n" value equal to 0.013.

$$Q = \frac{.000039748}{n} D^{2.66666667} \sqrt{S}$$

Where:

Q =	the capacity in mgd,	n =	the Manning n (n=.013)
D =	the diameter of the pipe in inches	S =	the sewer slope in percent.

2) Pumped flows.

- a) Includes a variety of different flows, including flows pumped from private site utility I`system (on-site), such as swimming pool filter backwash flows and grinder pump systems and WSSC wastewater pumping stations.
- b) Wastewater flows are calculated as follows:

Design gravity flow + instantaneous peak pump rates (when applicable)

- c) Sewage pump selection: At least one (1) standby pump must be provided and available for service at all times. Pumps must be of such capacity that with the largest unit out of service, the remaining units will be capable of delivering the peak flow described under item (b).
- d) Sewers shall be sized to carry the peak hydraulic flow at two-thirds full (i.e., the hydraulic grade line will be at  $d/D = .67$ ). Sewers with peak wastewater flows greater than 3.5 mgd shall



be sized to carry the peak hydraulic flow at 91% full.

- e) Force main velocities shall be a minimum of 2.0 feet per second and a maximum of 6.0 feet per second. The system shall be designed to minimize water hammer for normal operation situation and unusual circumstances such as power outages. The system must be designed to avoid column separation. Column separation is the most serious consequence of down surge and must be avoided. Refer to Part Two, Section 24 (Force Main Design).

### 3) Grinder Pumps and Pressure Sewers

- a) Least preferable method by WSSC for providing sewer service. Please see WSSC Standard Procedure number ENG 04-10 for policy and guidelines. Detention time in the pressure sewer prior to discharge to the gravity system should be less than 2 hours. Proposed systems that do not meet these specifications will require additional information from the Applicant and further review/assessment by the Commission.
- b) Non-residential development will be allowed service via dedicated grinder systems only when such a system is dedicated to a single customer. No other customers will be permitted to connect to the low-pressure main.
- c) For new grinder pump systems, applicants should follow manufacturer's directions for designing the systems. The WSSC will verify that the system is feasible and that the pumps to be installed are WSSC approved manufacturers. **(Environment One and FE Myers)**
- d) Additions to existing grinder pump systems, if permitted, must use the same make and similar pump model to those in the existing system. Consult WSSC for information on the available capacity in this situation.
- e) When modeling flows from grinder pump units in the downstream gravity systems, use the rate of 11 gallons per minute for each grinder pump unit for the Environment/One brand pumps. Please be aware that other manufacturers' pumps may have different flow rates. For example, a WSSC-approved F.E. Myers unit pumps at a rate of 20 gallons per minute or gpm.

### 4) Checking Downstream Capacity

- a) To determine the limiting capacity of the downstream sewers, use the Sewer Model or the As-Built plans. Based on the slope and diameter of the sewer main, determine which pipe will be the limiting capacity pipe.
- b) To determine the adequacy of the capacity of the existing downstream sewer pipe, add the proposed flow from the project under review, other authorized flows for which HPA Letters of Findings have been already issued which are still in effect, and the existing wastewater flows that drain into the sewer pipe under investigation, if applicable.
- c) Calculate Peak Wastewater Flow (PWF) as described on page Appendix C-6, item (3)(c), and add instantaneous peak pump rates (when applicable). If this flow is less than, or equal to the limiting capacity, then the downstream sewers are adequate.



## APPENDIX D

### WSSC Survey and Easement Criteria

#### a. General Survey Information.

- 1) The WSSC requires that all surveys and related work performed within WSSD be based upon **the datum defined below (NAD 83/91 horizontally and NGVD 29 vertically).**
- 2) This Appendix of the WSSC Pipeline Design Manual is intended to provide information, guidance and the minimum criteria necessary for the performance of surveys needed or required for any design, land or **easement** acquisition, or construction within the WSSD.
- 3) **All surveys shall be in accordance with the “Maryland Standards of Practice for Professional Land Surveyors and Property Line Surveyors” as adopted March 3, 1995 and as amended**

#### b. Surveying Control

##### 1) WSSC Datum:

- i) The WSSC used a plane rectangular grid system with its origin based on the dome of the Capitol building in Washington, D.C... This was based on the 1927 North American Datum. This original datum area covered by WSSC was quite small in 1918 and it was not until after 1945 that the area expanded rapidly to eventually include almost all of Montgomery and Prince George’s Counties. **There is No Survey grade conversion which can be applied to convert from one system to the other.** In the past some formulas were developed based on limited areas for a conversion of coordinates. However, these were only useful for plotting purposes and not of sufficient accuracy to be used for horizontal control outside of an 8 mile radius of the WSSC origin. Although this datum information is still available, **this datum is no longer maintained and is not the current horizontal datum for surveys in WSSD.**

##### 2) Horizontal Control:

- i) **Horizontal control shall be established by conventional closed traverse or Global Positioning System (GPS) surveys. Control points shall be referenced to the Maryland Coordinate System (NAD83/1991) horizontally and based on the WSSC Survey Control System. All other control points whether National Geodetic survey or State Highway, shall be permitted as long as they are either first or second order points.**
- ii) **All control loops to sites shall have a minimum closure of 1:15. GPS control points shall be established in accordance with the specifications and The Federal Geodetic Control Committee (FGCC) for using GPS relative positioning techniques as amended. All control points with their corresponding coordinate values shall be shown upon the plan sheets in their relative position to the project by scale. Values may be shown at the corresponding location of the point or in tabular form.**



### 3) Vertical Control:

- i) Vertical control shall be referred to the National Geodetic Vertical Datum of 1929 (NGVD '29) local reference to the WSSC Survey Control System or other designated bench marks available in the National Geodetic Survey database. A closed level loop shall be used to establish bench marks on the site using a minimum of two known bench marks to verify the elevations clearly shown and referenced in detail on the plans. **As the vertical datum has changed over the years, the Engineer shall not use elevations from as-built plans without field verification.**

### 4) Survey Marker Requirements: ``

#### a) Acceptable Survey Markers are:

- i) Brass disk set on top concrete monument or set in concrete;
- ii) Iron pipe or rod;
- iii) Rebar and Cap;
- iv) Drill hole (Horizontal control only);
- v) Cross cut or Square cut;
- vi) P.K.nail
- vii) Spike (Horizontal control only)

#### b) Unacceptable Survey Markers are:

- i) Manhole lids;
- ii) Fire hydrants

#### c) Other Requirement:

- i) At least one (1) benchmark on a sheet, with minimum of three (3) per job ,benchmarks should be no more than 400 feet from another benchmark.
- ii) In areas where no physical features remain close to the proposed construction, WSSC will decide on the proper method to proceed on a case by case basis.

5) The WSSC maintains a list of all established horizontal and vertical controls within the WSSD. Contact WSSC for additional information or data that may be available

6) WSSC Survey Control Stations that will be affected by the proposed construction shall be noted on the plans as being protected or to be relocated accordingly. Where there is a need to protect or relocate Control Stations, the WSSC shall be notified by the Consulting Engineer / Surveyor in writing prior to the approval of the plans

### c. Field Survey Standards

#### 1) General Information:

Field surveys shall be performed to fully comply with those requirements as set forth in COMAR 09.13.06.04. Depending on the magnitude and complexity of the project, subsurface information, such as soil borings, may be required. Topographic information shall show locations of all streets, buildings, pavements, sidewalks, structures, which may influence the design and layout of the collection or conveyance system. Information on existing utilities shall include the location of underground water lines, sanitary sewers, storm drains, gas mains, electric conduit, and similar





facilities.

**Aerial photogrammetry may NOT be used for the preparation of construction plans, unless sufficient field work is done to make any necessary adjustments to obtain satisfactory accuracy in both horizontal and vertical planes.**

2) Items to Include in Topographic Survey

- a) All buildings and other structures within and immediately adjacent to the project limits, together with all improvements, including wells, springs, septic tanks, drain fields, dry wells, etc.
- b) Property and right-of-way lines (proposed and existing) including right-of-way widths and identifying road names.
- c) Property information:
  - Owner Name (s)
  - Deed and recording references, including parcel number, lot number, subdivision name and record plat reference(s)
  - Property pipes, monuments or markers
  - Street address
- d) Roadway pavements curb lines, driveway entrances, walkways, fences, walls, etc., including types of materials, widths, heights, and all other descriptive data.
- e) Guardrails, sign posts, retaining walls, traffic lights, and other features related to the roadway safety.
- f) Horizontal and vertical location of existing utilities including but not limited to water mains, valves, cap and blow-offs, vaults, fire hydrants, water meters, curb stops, sewer mains, manholes, cleanouts, storm drains, storm drain inlets, culverts, gas mains, utility poles, telecommunication utilities, and other located utilities. These utilities shall include those that are overhead, surface and subsurface.
- g) Trees:
  - Trees 12-inches in diameter and larger within proposed rights-of-way shall be individually located and identified by type.
  - For existing developed properties, all trees regardless of size, shall be located and identified by size and type that exist on the landscaped area of the property, including hedges, shrubs, flower beds, gardens, planting boxes, etc.
  - For trees whose foliage overhangs the right-of-way or construction strip, the extent and diameter of the foliage (fall line) shall also be shown.



- The tree line shall be located and general characteristics of the wooded area given including approximate average size of the trees, density and general type of trees represented.
- h) Water courses, such as streams, springs, swales and ditch areas, shall be shown and located including edge of water and bottom of stream/ditch elevations at the deepest section.
- i) Vehicular access routes for off road or undeveloped areas shall be identified for use during construction.
- j) Mail boxes
- k) Curb cuts.
- l) Railroad tracks, bridges and ballast.
- m) In addition to the above items, the following shall also be shown in conjunction with the topography:
  - 100-year floodplain
  - Natural Resource District Boundary
  - Wetlands
  - 25 foot wetland buffer
  - Traverse points and references.
  - Existing and proposed drainage and utility easements
  - Chesapeake Bay Critical Area Boundary
- n) Identify and reference contract numbers of all existing and proposed water and sewer utilities within and adjacent to the project limits.
- o) On projects requiring permanent structures (ie. pumping stations, water booster stations, etc.), the extent of the area shown outside of the anticipated property or right-of-way shall be determined by the Engineer on a case by case basis, but shall not be less than 100 feet.

### 3) Standards for Depicting Existing Conditions

Surveys must not be performed while snow cover is on the ground.

All construction plans shall be drawn to scale and must clearly and completely depict all existing topographic and man-made features including above and below grade. In order to develop the required information to scale, the Consulting Engineer / Surveyor is required to conduct field surveys to accurately establish horizontal and vertical control points along the route of the project based on the Maryland State plane coordinate system (NAD1983/91).



As previously indicated, existing natural and man-made topographical features as developed through field survey activities are drawn onto the construction plans using standard notes, symbols and established drafting techniques to present a clear representation of the area.

In surveying, plotting and drafting of existing features onto the construction plans, the inclusion or elimination of information must be carefully evaluated in the Interest of efficiency of work, clarification of plans and sufficiency of representative information. A complete listing of required survey and as-built information to be included on the base plans is given in Section, “Topographic Surveys” of this manual. On projects requiring more detailed information, it is the responsibility of the Consulting Engineer / Surveyor to recognize the extent and detail of information necessary to show a complete picture of the project area. However, in no case shall the Engineer show less than the requirements listed in the Consulting Engineer / Surveyor’s scope of services with WSSC, the limit depicting the above topographic features shall be a minimum of 10-feet beyond each side of the easement or road right-of-way.

#### 4) Cross Sections

Where required, cross-sections shall be taken at fifty (50) foot stations and at intersecting roads, driveways, entrances, rivers, streams, and railroads. Cross-sections shall be at right angles or radial to the proposed alignment and extend a minimum of 100 feet beyond each side of the proposed facility and a minimum of 200 feet beyond anticipated project limits. The minimum distances shown herein shall be extended accordingly in order to provide sufficient information to established profile grade lines beyond the actual project limits or to locate other topography or topographic relief, relative to the design or construction of the proposed improvements. Cross sections shall be plotted on standard cross-section sheets of a quality that will provide acceptable prints

#### d. As-built Surveys

##### 1) General

It is extremely important that water and sewer plans accurately reflect as-built conditions upon completion of construction. The as-built information is used for future planning purposes, Miss Utility locating, the construction of future utility extensions, to verify the as-built conditions will not lead to future maintenance concerns, to verify adequate system capacity and to obtain electronic data to supplement the WSSC Geographic Information Systems.

##### 2) Location Method and Accuracy Requirements

- a) The Horizontal Method for locating As-built shall be by field surveys utilizing the Radial survey method or the GPS method. The Horizontal Positional Tolerances for As-built shall be sub foot, with a 95% level of confidence. Horizontal shall be reference to Maryland Coordinate System (NAD83/1991).
- b) The Vertical Method for locating As-built shall be by field surveys utilizing the Trig leveling, Differential leveling or GPS method. The Vertical Positional Tolerances for As-built shall be 0.07 feet of truth, with a 95% level of confidence. Vertical shall be reference to National Geodetic Vertical Datum of 1929 (NGVD29)



### 3) Water As-built

- a) Water as-built information shall be shown in GREEN ink.
- b) The Water as-built drawings shall also reflect any field changes to the plan of the utility.
- c) The Engineer shall re-draw horizontal locations of water valves and fire hydrants greater than the tolerance of five (5) feet horizontal on the as-built survey.
- d) Three swing ties to the center of each water valve.
- e) A Registered Surveyor or Engineer shall certify the Water As-Built.
- f) The Water As-Built information will be submitted on the most current, revised, plan.

### 4) Sewer As-built

- a) Sewer as-built information shall be shown in RED ink.
- b) The Sewer as-built drawings shall also reflect any horizontal and vertical field changes to the plan of the utility.
- c) The Engineer shall re-draw horizontal locations of Sewer manhole greater than the tolerance of five (5) feet horizontal on the as-built survey.
- d) Three swing ties to the center of each manhole cover.
- e) When manholes are built over an existing sewer provide a distance to the upstream and downstream manhole and inverts and rim elevations of each.
- f) Completion of the As Built Data box. Final By is to be the name of the Survey Company preparing the as-built information.
- g) The profile plan will be completed by crossing out elevations and stations that were built per plan. Even if they have not changed, they will be crossed out with a single line and the true elevation and station will be shown to insure that no measurements were missed
- h) Depth of manhole in vertical feet from top of rim to channel centerline.
- i) Sewer line lengths in linear feet from centerline of manhole cover to centerline of manhole cover
- j) Centerline of channel inverts elevations.
- k) Drop connection elevation at the centerline of manhole.
- l) Manhole rim elevations.
- m) Percent of sewer line grade to be calculated from centerline of manhole to centerline of



manhole except for those lines built @ .50% of grade or less. In those cases the lines are to be calculated and indicated on the as-built from the incoming invert at the inside manhole wall to the next upstream manhole's outgoing invert at the inside manhole wall.

- n) A Registered Surveyor or Engineer shall certify the Sewer As-Built
- o) The Sewer As-Built information will be submitted on the most current, revised, plan.

5) Swing Tie Requirements

- a) Swing ties are to be taken from permanent above ground structures provided in the following order of preference and are to be labeled, preferably under 100-feet.
  - (1) Fire hydrants.
  - (2) Water valves.
  - (3). Center of Manholes (sewer, water, and storm drain).Telecommunications, electric manholes (C&P, PEPCO, BG&E) and cable markers.
  - (4). Telephone poles, signal poles.
  - (5) House or building corners (well defined).
  - (6) Retaining walls.
  - (7) Curb box or cleanout stack.
  - (8) Point on line from the manhole to manhole.

**e. Stakeout Information, Easements and Construction Strips.**

- 1) For stakeout information, see Part Three, Section 1 (Survey and Stakeout Information).
- 2) For width of easements and construction strips, location of pipelines within the easement and other requirements, see Part Three, Section 2 (Easements and Construction Strips).

**f. Survey Checklist.**

- 1) The following Survey Checklist can be used as a guide when submitting plans to WSSC. Items listed in the checklist are general and may not cover all items that may be required to complete the design.



## SURVEY CHECKLIST

PROJECT NAME \_\_\_\_\_ CONTRACT NO. \_\_\_\_\_

1. Right(s) of Way provided as needed for proposed pipeline(s) crossing private property.
2. Submit record plats, etc. along with proposed pipeline, showing dedication of public streets.
3. Pipeline stakeout to be in accordance with Part Three, Section 1 (Survey and Stakeout Information).
4. Horizontal Control.
  - a. Traverse references shown on plans.
  - b. Pipeline curve data, in accordance with Part Three, Section 1 (Survey and Stakeout Information).
  - c. Horizontal datum in accordance with this Appendix.
5. Vertical Control.
  - a. Minimum of one (1) benchmark, each plan sheet, in accordance with Part Three, Section 1 (Survey and Stakeout Information).
  - b. Vertical datum in accordance with this Appendix.
6. North arrow with scales and coordinates, with grid ticks shown on plan sheets.
7. Horizontal and vertical datum shown on all plan sheets.
8. Private streets labeled in plan. If work is within a private street, easements needed for proposed pipeline(s) shown.
9. Private property identification.
  - a. On plan sheet, provide property owner's name(s), recording information (Liber/Folio).
  - b. On profile sheet, provide property owner's name(s).
10. Election district shown on plan.
11. Two-hundred (200) foot sheet number shown on all plan sheets.
12. Accurate vicinity map.
13. On plan sheet, label all existing pipeline(s), easement(s) recording information (Liber/Folio).



**g. WSSC Easement Standards.**

- 1) See Part Three, Section 2 (**Easements** and Construction Strips) for required widths and sizes.
- 2) Deed Descriptions for the easement. Descriptions should be metes and bounds or by centerline, and should conform to Maryland minimum standards. The following is the format to be used in writing an **easement** description:
  - a) Heading:
    - (1) Label heading as Schedule "A".
    - (2) Give purpose for the **easement** (for a sewer, water main, etc.).
    - (3) All the names of those who will be signatory to the document, (Grantor(s) name(s) should be same as listed on their deed unless evidence can be provided why not). After the name of owner, insert (OWNER). Also include the address of grantor and grantee.
    - (4) Provide Tax ID #(s) in upper right corner of document. If multiple Tax ID #s are excessive, a listing at the end of the document or attached sheet can be provided
  - b) First paragraph of the description.
    - (1) List all documents by which owner(s) obtained property if by multiple deeds or plats, state number, then list.
    - (2) Which documents contain descriptions (deeds and plats) (any referenced material must be submitted to WSSC, e.g., MSHA Plats, Subdivision Plats, Deeds, Will Records, etc.).
  - c) Second paragraph of the description.
    - (1) Point of Beginning. Reference the starting point of the **easement** to a deed or plat line of the property the **easement** is going through and also the adjacent property. Call out the line number, bearing and distance, as reference in the deeds. Include the meridian used in the deed or plat.
    - (2) Proof read description against sketch. (description to run clockwise). For curved courses, specify if they are Tangent or Non-tangent curves and give the following: arc length, direction, radius, chord, bearing and distance.
    - (3) Tie last line of the **easement** to a reference line of the deed or plat, see Point of Beginning.
  - d) Construction Strips. Reference proper side of the **easement**. Describe them simply but carefully. Determine if the right to trim or cut down trees is needed.
  - e) Surveyor's Certification: A statement should be included to the effect that the licensee either prepared or was in responsible charge of preparation of the description and any surveying work reflected in it per COMAR 09.13.06.12.
- 3) Easement Sketch.



- a) Show the following on the **easement** sketch: Owner's name, Adjacent owners with the deed reference (Liber/Folio), Point of beginning, Width of **Easement** and Construction Strips, Plat References, North Arrow with scale and meridian, Deed and/or plat line referenced, Sketch scale same as water and sewer plans. Show existing WSSC rights of way with deed references (Liber/Folio) and buildings/dwellings if close to an **easement** or construction strip.
- b) Outline the sketch with the following color scheme.
- (1) Property Owner Names: underline in RED, and outline Owner's Property in RED.
  - (2) Proposed **Easement** Lines: outline in GREEN.
  - (3) Existing WSSC **Easement** Lines: outline in BROWN.
  - (4) Proposed Construction Strips: outline in ORANGE.
  - (5) Point of beginning: underline in BLUE.
- c) Sketch may show multiple **Easements** and property owners, color scheme to be shown only for the applicable property.
- d) WSSC will provide the sketch number, when size has been determined. Sketch Number is to be placed in **Lower Right Corner** of the **Easement** sketch. Text size is to be at least 0.25" high.
- e) Sketch sizes for rights of way.

x	8 1/2	11	16	20	22
11	A				
12		B			
16		C	J		
20		D	K	P	
24		E	L	S	
30		F	M	Y	
34		G	N		Z*

\* maximum size for a Z sketch







## APPENDIX E

### SUBSURFACE INVESTIGATION REQUIREMENTS FOR WATER AND SEWER DESIGN AND CONSTRUCTION

#### a. General Requirements

- 1) All geotechnical investigations shall be planned and performed under the direct supervision of a Professional Geotechnical Engineer registered in the State of Maryland with a minimum of five (5) years experience in the performance and supervision of geotechnical engineering projects. All field and laboratory test data report shall be reviewed and verified by the Geotechnical Engineer.
- 2) Determine the coordinate location, station and offset from baselines as shown on the Plans, and ground surface elevation, for each boring and other test probes and show the information on the individual logs. Refer to “General Guidelines and Checklist for Subsurface Investigations” in this Appendix.
- 3) Visual soil identification as reported on the boring logs shall be in accordance with ASTM D-2488, Standard Practice for Description and Identification of Soils (Visual-Manual Procedure). For description for soil samples with laboratory test results, the description shall also include Unified Soil Classification System (USCS) soil classification.
- 4) Final boring and rock core logs shall be prepared and submitted using gINT software as supplied by Bentley Systems, Inc. Boring and test pit logs shall use WSSC’s Standard letter size boring and test pit log forms. Use the latest versions of gINT library, data templates and files available on WSSC’s website. See example reports in subsection (j) of this Appendix.
- 5) The Commission may request to inspect soil and rock samples obtained by the consultant.
- 6) The Geotechnical Engineer shall determine groundwater table depth/elevation and seepage conditions at the project site.
- 7) All drilling equipment and Standard Penetration Test (SPT) apparatus used for WSSC projects should be calibrated per ASTM D 4633 within the last two years of drilling date. Hammer energy efficiency shall be recorded on all boring logs for each drilling rig/SPT apparatus used.
- 8) All laboratory testing shall be performed by laboratories with AASHTO Materials Reference Laboratory (AMRL) certification for each specific test performed.

#### b. Soil Borings.

- 1) Washington Suburban Sanitary Commission (WSSC) normally determines the number and location of the soil borings. Locate borings for water mains 16-inch and larger with the concurrence of WSSC. The requirements for tunnel construction and subsurface tunnel investigations are specified in Part Three, Section 26 (Tunnel Design Criteria) and Appendix "F" (Soil Investigation Required for Soft Ground Tunnel Projects).
- 2) Boring depths and testing requirements: The type and number of tests required are primarily a function of the geotechnical variability of the site, the purpose of the study, and the amount of risk and potential consequences of failure. The project geotechnical engineer shall consider site



geology, existing soil survey, proposed design features and construction method etc. when determining the geotechnical investigation program. The investigation program should be flexible enough to be adjusted during the course of the investigation in case an unanticipated soil conditions are encountered. The following requirements should be considered as a minimum.

a) General water and sewer pipeline construction,

- (1) All borings are to be carried to a depth of three feet or three pipe diameters (whichever is deeper) below the proposed pipe invert, or to auger refusal. Space borings a maximum of three hundred (300) feet apart along all pipelines and locate additional borings at fittings, valves, etc. that require special thrust blocking design and at structure locations, such as valve vaults, manholes, etc. Extend the depth of these additional borings to ten (10) feet below the invert of the pipe. Where two pipelines are designed to be approximately parallel and separated by thirty five (35) feet or less, they may be considered as one pipeline when determining the number and spacing of borings, however, the depth of the borings will be determined by the invert elevation of the deeper pipeline. A minimum of two (2) borings per contract site is required.
- (2) In the event of auger refusal, verify that boring is not terminated on boulder. Core at least 10 ft. beyond refusal to confirm bedrock. If bedrock is confirmed before reaching the required boring depth, additional borings are required at one hundred (100) foot intervals in both directions along the proposed pipeline until a boring can be carried to three (3) feet below the pipe invert or the end of the pipeline is reached.

(3) Other Geotechnical features

For other geotechnical features that may be proposed for pipe line work, boring layout shall depend on the geometry of the proposed features, external loading and expected site soil and groundwater conditions. The boring layout should establish soil strata for design and identify ground water, soft soils and other potential geotechnical problems.

- (a) Cut and fill Slopes: Investigation depth should be, at a minimum fifteen (15) feet below the minimum elevation of cut slopes or 1.5 times the height of cut (whichever is deeper) unless a hard stratum is encountered below the minimum cut elevation. In locations where the base of cut is below ground-water level, increase depth of investigation as needed to determine the depth of underlying pervious strata. For fill slopes, investigation depth should be, at a minimum, equal to twice the fill height unless a hard stratum is encountered above this depth. If soft strata is encountered extending to a depth greater than twice the fill/cut height, investigation depth should be deep enough to fully penetrate the soft strata into competent material (e.g., stiff to hard cohesive soil, compact to dense cohesionless soil, or bedrock).
- (b) Retaining walls: Investigate to a depth below bottom of wall between 1 and 2 times the wall height or a minimum of ten (10) feet into bedrock. Investigation depth should be deep enough to fully penetrate soft highly compressible soils (e.g. peat, organic silt, soft fine grained soils) into competent material of suitable bearing capacity (e.g., stiff to hard cohesive soil, compact dense cohesionless soil, or bedrock).

[1] Shallow foundations: Depth of investigation should be:



- (1) Deep enough to fully penetrate unsuitable foundation soils (e.g., peat, organic silt, soft fine grained soils) into competent material of suitable bearing capacity (e.g. stiff to hard cohesive soil, compact to dense cohesionless soil or bedrock) and;
  - (2) At least to a depth where stress increase due to estimated footing load is less than 10% of the existing effective overburden stress and;
  - (3) If bedrock is encountered before the depth required by item (2) above is achieved, investigation depth should be deep enough to penetrate a minimum of 10 ft. into the bedrock. Rock investigation should be sufficient to characterize compressibility of infill material of near-horizontal to horizontal discontinuities.
- [2] Deep Foundations: In soil, depth of investigation should extend below the anticipated pile or shaft tip elevation a minimum of 20 ft. or a minimum of two times the maximum pile group dimension, whichever is deeper. All borings should extend through unsuitable strata such as unconsolidated fill, peat, highly organic materials, soft fine grained soils, and loose coarse-grained soils to reach hard or dense materials. For piles bearing on rock, a minimum of 10 ft. of rock core shall be obtained at each investigation point location to verify that the boring has not terminated on a boulder. For shafts supported on or extending into rock, a minimum of 10 ft. of rock core, or a length of rock core equal to at least three times the shaft diameter for isolated shafts or two times the maximum shaft group dimension, whichever is greater, shall be extended below the anticipated shaft tip elevation to determine the physical characteristics of rock within the zone of foundation influence.
- b) Soil borings may be performed by hand or mechanical equipment or a combination thereof. The minimum boring diameter is 3-1/2-inch when using flight or hand augers and 2-1/2-inch inside diameter using casing or hollow stem augers. Standard penetration tests are to be performed at two and one half (2-1/2) foot intervals for the upper ten (10) feet of the boring, at each five (5) feet thereafter, at a change of material and at the bottom of the boring. Standard penetration tests are to be made using a 2-inch OD, split-spoon sampler (ASTM D 1586) driven by a 140-pound hammer falling freely 30-inch. The number of blows required to drive the sampler a total of 18-inch in 6-inch intervals shall be recorded as the penetration resistance.
- 3) Sampling.
- a) **Disturbed soil sampling**
    - (1) Provide jar samples of soil from each split spoon penetration. Provide screw on top, wide mouth glass jars or bottles at least 3-1/2-inch high and approximately 1-3/4-inch diameter at the mouth and the inside diameter of the jar should be no more than 1/4-inch larger than the mouth. Metal screw caps should contain a rubber or waxed paper gasket. Label each jar with the contract number, boring number, depth of the sample and penetration resistance in blows per 6-inch.
    - (2) Collect bag samples at the proposed pipe depth of sufficient quantity to perform soil resistivity and other required tests if ferrous pipe materials will be used for the project and



at least one bag sample of each soil type for compaction testing as specified under Laboratory Testing, in this section and see the Corrosion Survey Checklist in Part Three, Section 28, Corrosion Control.

(3) Undisturbed soil sampling

Undisturbed soil sampling may be required for performing laboratory strength and consolidation tests per project design and construction requirements. Use Shelby tubes (ASTM D 1587), piston sample (ASTM D 6519) or other applicable samplers to extract soil. If block samples are collected from test pits or open cuts, follow ASTM D 4222. Laboratory testing conducted on undisturbed samples shall be performed no more than 7 calendar days after sample retrieval.

4) Groundwater observations. Measure and record the groundwater level at the following intervals:

- a) When first encountered during boring. Note this on the remark column of boring or test pit logs.
- b) One half (1/2) hour after all augers, sampling equipment or casings have been removed from the boring. This reading shall be referred to as the Zero hour reading.
- c) Twenty four (24) hours after the boring completion.
- d) If ground water readings are recorded later than 24 hours, make a note of these readings in the remark columns of borings and test pit logs.

5) Field testing for ferrous pipe materials. When required by the Corrosion Control Guidelines, Part Three, Section 28 (Corrosion Control), perform the following in-situ soil and groundwater testing for ferrous pipe materials:

- a) Redox potential (ASTM D 1498) of soil at the proposed pipe depth.
- b) Water-soluble chloride content (ASTM D 512) of soil at the proposed pipe depth. Chloride ion extraction using accepted industry methodology will be necessary prior to testing.
  - (1) Carbon Dioxide (CO<sub>2</sub>) content (ASTM D 513) of groundwater, if present; see the Corrosion Survey Checklist in Part Three, Section 28, Corrosion Control.



**c. Laboratory Testing.**

After collecting soil and rock samples, laboratory tests shall be performed to quantify material properties and verify design assumptions. Sufficient laboratory testing shall be performed to represent the in-situ conditions. All standard soil and rock sample laboratory testing shall be performed in accordance with the appropriate ASTM standards.

- 1) Determine the natural moisture content, **atterberg limts** of all jar samples and report this information on the boring logs. 2) Perform the following:
  - a) Gradation analysis, liquid limit, plastic limit and shrinkage limit on at least one jar sample of each soil type (ASTM D 2487) encountered in the borings for each contract. Plot the gradation analysis on the WSSC or computer generated Gradation Curve Chart. Also report Atterberg Limits on this form.
  - b) Moisture-density relationship (ASTM D 698) on at least one bag sample of each soil type encountered in the borings for each contract. Plot the moisture-density relationship on the WSSC or computer generated Moisture Density Curve Chart.
- 2) If **ferrous pipe materials** are to be used, perform the following and provide this information on the boring logs or a separate sheet.
  - a) pH measurements (ASTM G 51) on the jar sample collected nearest the proposed pipe depth; **see the Corrosion Survey Checklist in Part Three, Section 28, Corrosion Control.**
  - b) Soil resistivity measurements (ASTM G 57) on the bag samples collected at the proposed pipe depth, **see the Corrosion Survey Checklist in Part Three, Section 28, Corrosion Control.**
- 3) Other types of laboratory tests such as tri-axial, direct shear, consolidation, etc. may be performed per project design requirements. Follow applicable ASTM standards for test procedures. The following minimum requirements shall also apply;
  - a) Laboratory consolidated undrained (CU) and unconsolidated undrained (UU) testing shall be used to determine the undrained shear strength,  $S_u$ .
  - b) For Determination of the undrained shear strength using in situ testing such as CPT and DMT, the undrained shear strength shall be calibrated with the appropriate level of triaxial testing. For relatively thick deposits of cohesive soil layers, profiles of the undrained shear strength  $S_u$  as function of depth shall be obtained so that the deposit stress history and properties can be ascertained.
  - c) Strength measurements from hand torvanes, pocket penetrometers, or unconfined compression tests shall not be used to determine undrained shear strength.
  - d) Long-term effective stress strength parameters,  $c'$  and  $\Phi'$ , of cohesive soils shall be evaluated by consolidated drained (CD) triaxial tests, or consolidated undrained (CU) triaxial tests with pore pressure measurements.
  - e) Long-term effective stress strength parameters,  $c'$  and  $\Phi'$ , of cohesive soils shall not be



evaluated by Direct Shear tests.

- 4) Enter Atterberg limit, natural moisture content and other test results in the appropriate fields of the “Sample” table in the final gINT logs. Soil corrosively test results should be entered in the final gINT file in the appropriate fields in “WSSC Soil Corrosion Tests & evaluation” table. Use the latest versions of gINT library, data templates and files available on WSSC’s website.

#### **d. In-situ Tests**

In addition to soil borings, other geotechnical in-situ investigation techniques such as Cone Penetration Test (CPT), Pressure Meter Test (PMT) and Flat dilatometer tests (DMT) may be performed to supplement geotechnical data obtained from conventional borings for site characterization. In situ tests are used to directly obtain field measurements of useful soil and rock engineering properties. In soil, in situ testing includes tests that determine the physical properties of the ground, such as shear strength from CPT and ground deformation properties from PMT. CPT shall be conducted in accordance with ASTM D 5778 & ASTM D 3441. For DMT, follow ASTM D 6635. Conduct PMT per ASTM D 4719. For other types of in-situ tests, follow the appropriate ASTM standards.

#### **e. Boring, Test Pit and other Logs.**

Borings and test pit logs for each boring must be completed and should be in the standard WSSC boring and test pit log formats. A Bentley gINT software report templates are available on WSSC website for this use. Other pertinent information that need to be shown on test logs including in-situ tests are included on “General guidelines and Checklist for Subsurface Investigations” in this appendix.

#### **f. Geotechnical Report requirements:**

All geotechnical reports (draft, interim or final) shall be prepared, signed and sealed by a professional geotechnical engineer registered in the State of Maryland. All relevant design calculations and computer program results should be checked and initialed by the Professional Engineer. The Geotechnical Engineer must certify all data. The certification will state that the boring locations given on the boring log(s) are accurate within  $\pm 2.0$  feet, the surface elevation on the boring log(s) is accurate within  $\pm 0.5$  feet and the soil descriptions on each boring log were made after careful review of field boring data, visual inspection of the soil samples obtained therefrom and correlation with all laboratory test results.

Geotechnical Reports shall include the following items at a minimum as applicable:

- 1) Project contract number, description and scope,
- 2) A detailed description of geological and subsurface conditions for each Project element (including a description of site stratigraphy);
- 3) Field investigation procedures;
- 4) A description of groundwater conditions and if ground water impacts the construction, means of dewatering and/or other solutions;



- 5) Results of laboratory tests;
- 6) Interpretation and analysis of the subsurface data including values assigned to all applicable soil parameters for design;
- 7) Complete discussions of all geotechnical analyses and design;
- 8) Conclusions and recommendations for foundation types for structures, fill and cut slopes, retaining walls, ground improvement, requirements for backfill materials;
- 9) Designs for support of excavation;
- 10) Results of instrumentation and monitoring and post-construction monitoring summaries;
- 11) Potential settlement, bearing capacity, stability or other geotechnical problems and analysis results;
- 12) Pipelines - Corrosion evaluation for pipes (as applicable), special construction requirements, backfill and bedding material.
- 13) Thrust restraint calculations.
- 14) Foundations: Shallow foundations calculations including allowable bearing capacity, estimated differential and total settlements, and rotations If deep foundations are proposed, individual pile and pile group design calculations including axial and lateral capacity for the pile type, size, and length to achieve the required capacities (including any effects of liquefaction and down drag); estimated pile and pile group settlement;
- 15) Retaining Walls: Wall design calculations including the results of the global and internal stability analyses; analyses of total, differential, and secondary settlements; and, calculations for analyses of sliding, overturning, and bearing pressure for live and seismic loadings;
- 16) Cut/fill slopes: The results of the slope stability analyses, including external loading from live and seismic loading, the recommended side-slopes of all slopes and the search limits and the most critical failure surface should be highlighted; input and output files should be included. For fill slopes (if applicable), results of settlement analyses, including predictions of the magnitude and duration of primary, secondary, and post-construction settlements. Evaluation of rock cut slopes shall clearly describe the rock bedding characteristics, including strike and dip and a detailed description of the analysis completed to assure stability.
- 17) Plans and cross sections of the area covered by the report;
- 18) Locations plan and results of borings, test pits, rock coring, in-situ and other pertinent geotechnical tests;
- 19) Geotechnical soil profiles of sections analyzed
- 20) Copies of any other geotechnical report referenced/referred in the report;
- 21) Specific engineering recommendations for design;
- 22) Recommended geotechnical special provisions;





23) Limitation of Geotechnical investigation and recommendations

**g. Submittals.**

1) Electronic data submittal

- a) Submit the Geotechnical reports (interim/draft/final) in pdf format. The reports should be signed and sealed by the Geotechnical engineer of record for the project. The report should include the minimum items listed in the section above.
- b) Submit final Geotechnical boring, test pit and applicable laboratory data in pdf and gINT format. The final gINT data should be the same as the final Geotechnical report. Use the latest versions of gINT library, template and project files available on the WSSC website. Final gINT file shall include applicable laboratory and corrosion evaluation test results. Refer to Subsections (1) and (7) in this appendix for “General guidelines and Checklist for Subsurface Investigations” and example reports.

2) Hard Copy Submittal

- a) Submit three (3) hard copies the Geotechnical report to the following address.

WSSC (project manager and office),  
14501 Sweitzer Lane, Laurel, Maryland 20707

- b) Submittals for the soil data must be clean, legible and reproducible, submittals that do not meet these requirements will not be accepted.



## APPENDIX F

### SOIL INVESTIGATION FOR SOFT GROUND TUNNEL PROJECTS

#### a. General Requirements

1. All geotechnical investigations shall be planned and performed under the direct supervision of a Professional Geotechnical Engineer registered in the State of Maryland with a minimum of ten (10) years experience in the performance and supervision of geotechnical engineering projects. All field and laboratory test data report shall be reviewed and verified by the Geotechnical Engineer.
2. Determine the coordinate location, station and offset from baselines as shown on the Plans, and ground surface elevation, for each boring and other test probes and show the information on the individual logs. Refer to “General Guidelines and Checklist for Subsurface Investigations” in Appendix E.
3. Visual soil identification as reported on the boring logs shall be in accordance with ASTM D-2488, Standard Practice for Description and Identification of Soils (Visual-Manual Procedure). For description for soil samples with laboratory test results, the description shall also include Unified Soil Classification System (USCS) soil classification.
4. Final boring and rock core logs shall be prepared and submitted using gINT software as supplied by Bentley Systems, Inc. Boring and test pit logs shall use WSSC’s Standard letter size boring and test pit log forms. Use the latest versions of gINT library, data templates and files available on WSSC’s website. See example reports in subsection (j) of Appendix E.
5. The Commission may request to inspect soil and rock samples obtained by the consultant.
6. The Geotechnical Engineer shall determine groundwater table depth/elevation and seepage conditions at the project site.
7. All drilling equipment and Standard Penetration Test (SPT) apparatus used for WSSC projects should be calibrated per ASTM D 4633 within the last two years of drilling date. Hammer energy efficiency shall be recorded on all boring logs for each drilling rig/SPT apparatus used.
8. All laboratory testing shall be performed by laboratories with AASHTO Materials Reference Laboratory (AMRL) certification for each specific test performed.

#### b. Soil Borings.

- 1) Number and location of borings. When the tunnel is less than sixty (60) feet long, provide a minimum of two (2) borings, one (1) at each end of the tunnel. When the tunnel is equal to or longer than sixty (60) feet but shorter than six hundred (600) feet, provide three (3) borings, one (1) at each end of the tunnel and one (1) near the center. If the tunnel length is equal to or greater than six hundred (600) feet, provide a minimum of four (4) borings, located one (1) at each end of the tunnel and at locations between at spacing of not more than three hundred (300) feet.



2) Boring depth and sampling requirements.

- a) Extend the depth of the borings a minimum of **one and half (1.5) times tunnel diameter (D)** or five (5) feet, whichever is deeper, below the invert of the tunnel. Except in the borings for railway tunnels, Standard Penetration Tests (SPT) are to be performed at two and one half (2-1/2) feet below the surface, at each five (5) feet thereafter and at any change of material, to a depth of one tunnel diameter above the tunnel. From one tunnel diameter above to one and half (1.5) times tunnel diameter below the tunnel, take continuous standard split spoon samples (ASTM D 1586). For soil borings for railway tunnels, SPT tests are to be performed and samples are to be taken continuously from the ground surface to the bottom of the boring. If soft to medium clays or cemented soils are encountered, obtain at least one undisturbed sample (ASTM D 1587) for each stratum.
- b) **Borings at shafts including access shafts and jacking pits should extend at least 1.5 times the depth of the shaft for design of the shoring system and shaft foundation.**
- c) Describe each sample as outlined in ASTM D 2488. Retain a representative sample of each type of material encountered in the split spoon sample for possible examination by WSSC personnel until contract is awarded.
- d) If auger refusal is encountered in a drilled hole before the depth specified above is reached, do not terminate the drilling. Advance the drilling continuously using a double tube core barrel, with a diamond bit, capable of retrieving rock samples at least 1-5/8-inch diameter (ASTM D 2113). Determine the percent of core recovery and Rock Quality Designation (RQD).

3) Groundwater and observation well requirements.

- a) If ground water is encountered in the boring, record the water table in each boring upon completion and at twenty four (24) hours after the completion of the boring except for the two end borings.
  - b) Install an observation well as shown on Sketch "HH" at the boring at each end of the tunnel for continuous ground water monitoring. Record at least one additional water level reading prior to the submission of the tunnel design to WSSC.
- 4) Grouting of boring hole(s). Fill all soil boring holes with **sealing material at the completion of the drilling or at the end of ground water monitoring period as specified above, following the removal of any observation wells. Sealing materials shall consist of either neat cement and water or a cement grout. Neat cement and water shall be composed of one (1) bag of Portland cement to five (5) to eight (8) gallons of water. Cement grout shall be composed of not more than two (2) parts of sand and one (1) part of cement (per bag of cement) to five (5) to eight (8) gallons of water.**



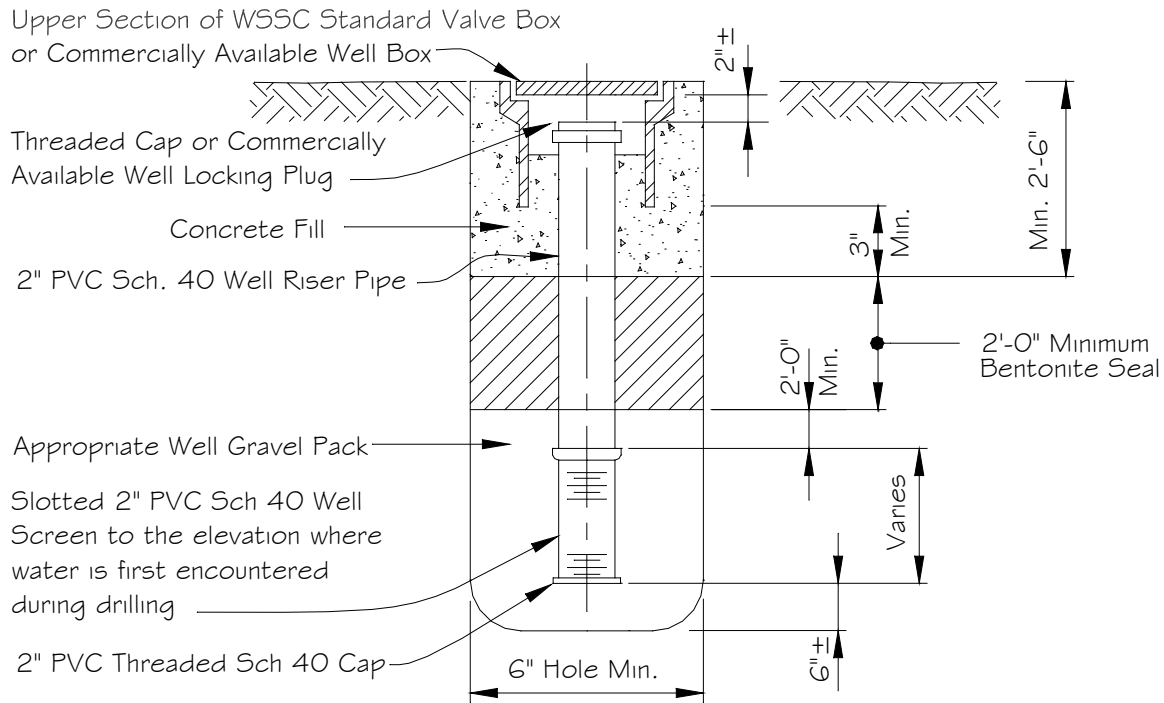

SKETCH "HH"  
Observation Well

### c. Laboratory Testing.

After collecting soil and rock samples, laboratory tests will be performed to quantify material properties and verify design assumptions. Sufficient laboratory testing shall be performed to represent the in-situ conditions. All standard soil and rock sample laboratory testing shall be performed in accordance with the appropriate ASTM standards.

- 1) Perform laboratory tests on the samples obtained. Select samples to be tested after review of the soil samples and field logs. The following are the minimum tests to be performed on the soil samples:
  - a) Classification of all samples in accordance with the Unified Soil Classification System (ASTM D 2487).
  - b) Moisture content tests (ASTM D 2216) and sieve analysis (ASTM D 422), made on representative cohesionless soil samples.
  - c) Moisture content, density and atterberg limit (ASTM D 4318) tests, performed on representative samples that exhibit a plastic nature.
  - d) Unconfined compression tests (ASTM D 2166), made on undisturbed clay and cemented soil samples.
  - e) Laboratory unconfined compression tests (ASTM D 2938), performed on selected rock samples.



- 2) Other types of laboratory tests such as tri-axial, direct shear, consolidation, etc. may be performed per project design requirements. Follow applicable ASTM standards for test procedures. The following minimum requirements shall also apply;
  - a) Laboratory consolidated undrained (CU) and unconsolidated undrained (UU) testing shall be used to determine the undrained shear strength,  $S_u$ .
  - b) For Determination of the undrained shear strength using in situ testing such as CPT and DMT, the undrained shear strength shall be calibrated with the appropriate level of triaxial testing. For relatively thick deposits of cohesive soil layers, profiles of the undrained shear strength  $S_u$  as function of depth shall be obtained so that the deposit stress history and properties can be ascertained.
  - c) Strength measurements from hand torvanes, pocket penetrometers, or unconfined compression tests shall not be used to determine undrained shear strength.
  - d) Long-term effective stress strength parameters,  $c'$  and  $\Phi'$ , of cohesive soils shall be evaluated by consolidated drained (CD) triaxial tests, or consolidated undrained (CU) triaxial tests with pore pressure measurements.
  - e) ong-term effective stress strength parameters,  $c'$  and  $\Phi'$ , of cohesive soils shall not be evaluated by Direct Shear tests.
- 3) Enter atterberg limits, natural moisture content and other laboratory test results in the appropriate fields of the "Sample" table in the final gINT logs. Use the latest versions of gINT library, data templates and files available on WSSC's website.

#### **d. In-situ Testing**

In addition to soil borings, other geotechnical in-situ investigation techniques such as Cone Penetration Test (CPT), Pressure Meter Test (PMT) and Flat dilatometer tests (DMT) may be performed to supplement geotechnical data obtained from conventional borings for site characterization. In situ tests are used to directly obtain field measurements of useful soil and rock engineering properties. In soil in situ testing include tests that determine the physical properties of the ground, such as shear strength from CPT CPT and ground deformation properties from PMT. CPT shall be conducted in accordance with ASTM D 5778 & ASTM D 3441. For DMT, follow ASTM D 6635. Conduct PMT per ASTM D 4719. For other types of in-situ tests, follow the appropriate ASTM standards.

#### **e. Geophysical Testing**

Applicable geophysical investigation methods may be used to supplement geotechnical data obtained from conventional borings and sampling methods. Geophysical tests are indirect methods of exploration in which changes in certain physical characteristics such as magnetism, density, electrical resistivity, elasticity, or a combination of these are used as an aid in developing subsurface information. Geophysical methods provide an expeditious and economical means of supplementing information obtained by direct exploratory methods, such as borings, test pits and in situ testing; identifying local anomalies that might not be identified by other methods of exploration; and defining strata boundaries between widely spaced borings for more realistic prediction of subsurface profiles. Typical uses of geophysical tests include determination of the top of bedrock, the ripability of rock,



the depth to groundwater, the limits of organic deposits, the presence of voids, the location and depth of utilities, the location and depth of existing foundations, and the location and depth of other obstruction, to note just a few. In addition, geophysical testing can also obtain stiffness and dynamic properties which are required for numerical analysis. All geophysical investigations shall be planned and performed under the direct supervision of a geophysicist with a minimum of 10 years of relevant professional experience.

**f. Geotechnical Report requirements:**

All geotechnical reports (draft, interim or final) shall be prepared, signed and sealed by a professional geotechnical engineer registered in the State of Maryland. All relevant design calculations and computer program results should be checked and initialed by the Professional Engineer. The Geotechnical Engineer must certify all data. The certification will state that the boring locations given on the boring log(s) are accurate within  $\pm 2.0$  feet, the surface elevation on the boring log(s) is accurate within  $\pm 0.5$  feet and the soil descriptions on each boring log were made after careful review of field boring data, visual inspection of the soil samples obtained therefrom and correlation with all laboratory test results.

Refer to Section C-26 for additional requirements of geotechnical reports for tunnel design purposes.

**g. Submittals.**

1. Electronic data submittal

- i. Submit the Geotechnical reports (interim/draft/final) in pdf format. The reports should be signed and sealed by the Geotechnical engineer of record for the project. The report should include the minimum items listed in the section above.
- ii. Submit final Geotechnical boring, test pit and applicable laboratory data in pdf and gINT format. The final gINT data should be the same as the final Geotechnical report. Use the latest versions of gINT library, template and project files available on the WSSC website. Final gINT file shall include applicable laboratory and corrosion evaluation test results. Refer to Subsections (i) and (j) in Appendix E for “General guidelines and Checklist for Subsurface Investigations” and example reports.

2. Hard Copy submittal

- a) The following results are to be submitted as part of the Preliminary Tunnel Submittal review materials to: (For a description of the Preliminary Tunnel Submittal review materials, see Part Three, Section 26 (Tunnel Design Criteria)).

WSSC (Project Manager and Office)  
14501 Sweitzer Lane  
Laurel, Maryland 20707

- (1) Map of boring locations. A copy of the construction plans with boring locations marked will be adequate.
- b) Boring logs and other test logs Refer to General guidelines and Checklist for Subsurface Investigations” in this Appendix E.



(1) The log for each boring (WSSC boring log form) must be completed in full.

- (a) Penetration resistance of each split spoon sample per 6-inch of spoon penetration. Core recovery and RQD for rock cores if rock is encountered.
  - (b) Boring surface elevation.
  - (c) Elevation and depth from surface to each soil and rock (if encountered) stratum.
  - (d) Depth and elevation of bottom of boring.
  - (e) Soil description including color, moisture condition, consistency/relative density and ASTM classification designation (ASTM D 2488).
  - (f) Extent and character of weathering, type, color and hardness of rock if it is encountered.
  - (g) Orientation of bedding or foliation relative to axis of boring if rock is encountered.
  - (h) Ground water information.
  - (i) Information on any bag samples, special observations or other pertinent remarks such as presence of sand stringers, slickenside clay layers, etc.
- c) WSSC gradation curves (in triplicate).
  - d) Tabulate field moisture contents, density values, atterberg limits and rock unconfined compressive strengths according to boring and sample numbers (in triplicate).
  - e) **Rock unconfined** compression test if the test is performed (in triplicate).

**h. General Guidelines and Checklist for Subsurface Investigations**

**Purpose:** The purpose of the following check list is to ensure that consistent geotechnical test data is collected for all WSSC projects. The items contained in the following check list should only be considered as a minimum. Detailed investigation requirements shall be set based on the project design and construction requirements. The project Geotechnical consultant should make sure all data included in the test logs are collected in accordance with the applicable ASTM standards.

**Applicable to:** Boreholes, Test pits, Cone Penetration Tests, Flat Dilatometer Tests



## **CHECKLIST FOR SUBSURFACE INVESTIGATIONS**

No.	CHECK LIST ITEMS	YES	NO	N/A	REMARK
<b>1</b>	<b>General</b>				
1.1	Record names of the project prime consultant, and geotechnical consultant/contractor on all test logs.	<input type="checkbox"/>	<input type="checkbox"/>	<input type="checkbox"/>	
1.2	Record Contract No. and Project description on all test logs consistent with project plans.	<input type="checkbox"/>	<input type="checkbox"/>	<input type="checkbox"/>	
1.3	Record start and finish dates of tests on all logs.	<input type="checkbox"/>	<input type="checkbox"/>	<input type="checkbox"/>	
1.4	Use consistent test identifications or designations. See examples below. * BH - Bore Hole (BH-1, BH-2.....) * TP - Test Pit (TP-1, TP-2.....) * CPT - Cone Penetration Test (CPT-1, CPT-2....) * DMT - Dilatometer Test (DMT-1, DMT-2.....) * MW - Ground Water Monitoring Well (MW-1,...)	<input type="checkbox"/>	<input type="checkbox"/>	<input type="checkbox"/>	
1.5	Refer to ASTM D 5434 for general information that should be recorded during field subsurface explorations in soil and rock.	<input type="checkbox"/>	<input type="checkbox"/>	<input type="checkbox"/>	
<b>2</b>	<b>Test location and depth</b>				
2.1	Record survey stations and offsets of all test locations on logs.	<input type="checkbox"/>	<input type="checkbox"/>	<input type="checkbox"/>	
2.2	Record coordinates (Easting & Northing) of all test locations. Refer to WSSC Pipe design manual, Appendix D for coordinate system.	<input type="checkbox"/>	<input type="checkbox"/>	<input type="checkbox"/>	
2.3	Measure and record surface elevations of all test locations.	<input type="checkbox"/>	<input type="checkbox"/>	<input type="checkbox"/>	
2.4	If tests are relocated by more than 5 ft. in any direction from their original location, record new coordinates elevations and reasons for relocation.	<input type="checkbox"/>	<input type="checkbox"/>	<input type="checkbox"/>	
2.5	Measure and record depth of bottom of test locations.	<input type="checkbox"/>	<input type="checkbox"/>	<input type="checkbox"/>	
2.6	Record any cave-in depths and time of cave-in (applicable to boreholes and test pits).	<input type="checkbox"/>	<input type="checkbox"/>	<input type="checkbox"/>	
<b>3</b>	<b>Drilling Equipment - Applicable to Boreholes</b>				
3.1	Record the type of rig used.	<input type="checkbox"/>	<input type="checkbox"/>	<input type="checkbox"/>	
3.2	Record the weight of standard penetration test (SPT) Hammer.	<input type="checkbox"/>	<input type="checkbox"/>	<input type="checkbox"/>	
<b>No.</b>	<b>CHECK LIST ITEMS</b>	<b>YES</b>	<b>NO</b>	<b>N/A</b>	<b>REMARK</b>
3.3	Record casing auger size.	<input type="checkbox"/>	<input type="checkbox"/>	<input type="checkbox"/>	





3.4	Record size of core.	<input type="checkbox"/>	<input type="checkbox"/>	<input type="checkbox"/>	
3.5	Record size of drilling.	<input type="checkbox"/>	<input type="checkbox"/>	<input type="checkbox"/>	
3.6	Record SPT hammer efficiency as calibrated per ASTM D 4633 within the last 2 years of drilling date.	<input type="checkbox"/>	<input type="checkbox"/>	<input type="checkbox"/>	
3.7	Record the type of core barrel used.	<input type="checkbox"/>	<input type="checkbox"/>	<input type="checkbox"/>	
<b>4</b>	<b>Soil Sampling - Applicable for Boreholes /Test Pits</b>				
4.1	Visual description of soil samples should be per ASTM D 2488.	<input type="checkbox"/>	<input type="checkbox"/>	<input type="checkbox"/>	
4.2	Make sure boreholes/test pits are clean prior to taking samples.	<input type="checkbox"/>	<input type="checkbox"/>	<input type="checkbox"/>	
4.3	Perform Standard Penetration Testing (SPT) per ASTM 1586.	<input type="checkbox"/>	<input type="checkbox"/>	<input type="checkbox"/>	
4.4	Disturbed soil samples : * Split spoon samples - follow ASTM D 1586	<input type="checkbox"/>	<input type="checkbox"/>	<input type="checkbox"/>	
4.5	Undisturbed Soil Samples:				
	* Thin wall tube samples - follow ASTM D 1587	<input type="checkbox"/>	<input type="checkbox"/>	<input type="checkbox"/>	
	* Piston samples - follow ASTM D 6519				
	* Block samples - follow ASTM D 4220				
4.6	Measure and record sample recovery.	<input type="checkbox"/>	<input type="checkbox"/>	<input type="checkbox"/>	
4.7	Use moisture proof containers to place samples per ASTM 4220.	<input type="checkbox"/>	<input type="checkbox"/>	<input type="checkbox"/>	
4.8	Label, transport and store samples per ASTM 4220.	<input type="checkbox"/>	<input type="checkbox"/>	<input type="checkbox"/>	
<b>5</b>	<b>Rock Sampling - Applicable to Boreholes</b>				
5.1	Follow ASTM D 2113 for rock core drilling and sampling.	<input type="checkbox"/>	<input type="checkbox"/>	<input type="checkbox"/>	
5.2	Rock core specimens should be extracted, handled, placed and labeled per ASTM 5079.	<input type="checkbox"/>	<input type="checkbox"/>	<input type="checkbox"/>	
5.3	Mark and identify rock core breaks per ASTM 5079.	<input type="checkbox"/>	<input type="checkbox"/>	<input type="checkbox"/>	
5.4	Calculate and record percent recovery per ASTM D 2113.	<input type="checkbox"/>	<input type="checkbox"/>	<input type="checkbox"/>	
5.5	Record any loss of circulating water and addition of extra drilling water during rock coring.	<input type="checkbox"/>	<input type="checkbox"/>	<input type="checkbox"/>	
5.6	Calculate and record Rock Quality Designation (RQD) per ASTM D 6032.	<input type="checkbox"/>	<input type="checkbox"/>	<input type="checkbox"/>	
<b>6</b>	<b>Ground water level</b>				
6.1	Record ground water level at the completion of drilling	<input type="checkbox"/>	<input type="checkbox"/>	<input type="checkbox"/>	
6.2	Record ground water level after stabilizing (24 hr)	<input type="checkbox"/>	<input type="checkbox"/>	<input type="checkbox"/>	
<b>No.</b>	<b>CHECK LIST ITEMS</b>	<b>YES</b>	<b>NO</b>	<b>N/A</b>	<b>REMARK</b>
6.3	Record any artesian ground water condition observed.	<input type="checkbox"/>	<input type="checkbox"/>	<input type="checkbox"/>	



<b>7</b>	<b>Observations</b>				
7.1	Record any obstructions encountered during drilling as remark.	<input type="checkbox"/>	<input type="checkbox"/>	<input type="checkbox"/>	
7.2	Record loss of circulating water and addition of extra drilling water during rock coring.	<input type="checkbox"/>	<input type="checkbox"/>	<input type="checkbox"/>	
7.3	Record any procedures used for maintaining an open bore hole.	<input type="checkbox"/>	<input type="checkbox"/>	<input type="checkbox"/>	
7.4	Record or note any difficulties during drilling (coring, boulders, surging or rise of sands in casing, and cavers).	<input type="checkbox"/>	<input type="checkbox"/>	<input type="checkbox"/>	
<b>8</b>	<b>Electronic Log submittal - Applicable to Boreholes and Test pits</b>				
8.1	Use WSSC standard boring or test pit log format for reporting final boring logs. A gINT library and project files are provided for use. Use latest version of gINT library and project files available on WSSC's website.	<input type="checkbox"/>	<input type="checkbox"/>	<input type="checkbox"/>	
8.2	Include laboratory index soil tests (natural moisture content, liquid limit and plasticity index) and soil corrosion tests on final gINT files.	<input type="checkbox"/>	<input type="checkbox"/>	<input type="checkbox"/>	
8.3	Submit final gINT log files with the project geotechnical report	<input type="checkbox"/>	<input type="checkbox"/>	<input type="checkbox"/>	
<b>9</b>	<b>Cone Penetration Test (CPT)</b>				
9.1	Perform Test per ASTM D 5778 and ASTM D 3441 as applicable.	<input type="checkbox"/>	<input type="checkbox"/>	<input type="checkbox"/>	
9.2	Data to be collected includes corrected tip resistance, side friction and pore water pressure.	<input type="checkbox"/>	<input type="checkbox"/>	<input type="checkbox"/>	
9.3	With the final geotechnical report, provide CPT test data in excel/spreadsheet.	<input type="checkbox"/>	<input type="checkbox"/>	<input type="checkbox"/>	
9.4	Provide CPT log reports in pdf format.	<input type="checkbox"/>	<input type="checkbox"/>	<input type="checkbox"/>	
<b>10</b>	<b>Flat Dilatometer Test (DMT)</b>				
10.1	Perform Test per ASTM D 6635.	<input type="checkbox"/>	<input type="checkbox"/>	<input type="checkbox"/>	
10.2	Data to be collected should at least include A, B, & C readings, and thrust force, depths (elevations).	<input type="checkbox"/>	<input type="checkbox"/>	<input type="checkbox"/>	
10.3	Report test data in graphical and tabulated format and include at least an interpretation of the soil behavior type, Dilatometer Modulus (Ed), Material Index (Id), Horizontal Stress Index (Kd), Pore pressure Index (Ud).	<input type="checkbox"/>	<input type="checkbox"/>	<input type="checkbox"/>	
10.4	With the final geotechnical report, provide DMT test data in excel/spreadsheet format.	<input type="checkbox"/>	<input type="checkbox"/>	<input type="checkbox"/>	



**i. Referenced ASTM standards for General Guidelines and Checklist for Subsurface Investigations.**

<b>No.</b>	<b>ASTM Standard</b>	<b>Title</b>
1	ASTM D 1586	Standard Penetration Test (SPT) and split barrel sampling of soils
2	ASTM D 1587	Practice for thin walled tube sampling of soils
3	ASTM D 2113	Practice for diamond core drilling for soil investigation
4	ASTM D 2488	Practice for description and identification of soils (Visual-Manual Procedure)
5	ASTM D 2487	Classification of Soils for Engineering Purposes (USCS)
6	ASTM D 3441	Mechanical Cone Penetration Tests of Soil
7	ASTM D 4220	Practice for preserving and transporting soil samples
8	ASTM D 4633	Energy Measurement for Dynamic Penetrometers
9	ASTM D 4750	Test method for determining subsurface liquid levels in a borehole or monitoring well (Observation well)
10	ASTM D 5079	Practice for preserving and transporting rock samples
11	ASTM D 5092	Design and installation of ground water monitoring wells in aquifers
12	ASTM D 5778	Test Method for electronic cone penetration testing (CPT) of soils
13	ASTM D 6032	Determining Rock Quality Designation (RQD) of Rock Core
14	ASTM D 6519	Sampling of Soil Using the Hydraulically Operated Stationary Piston Sampler
15	ASTM D 6635	Performing the Flat Plate Dilatometer
16	ASTM D 4719	Standard Test Methods for Prebored Pressuremeter Testing in Soils

**j Example gINT Reports**

- 1) Form No. TSG/GEO/01: WSSC Standard boring log
- 2) Form No. TSG/GEO/02: WSSC Standard Test Pit log
- 3) Form No. TSG/GEO/03: Soil Corrosivity Test Summary for Metallic Pipes

See the following pages for samples of these reports.



TSG/GEO/01  
8-31-2015

**WASHINGTON SUBURBAN SANITARY COMMISSION  
STANDARD BORING LOG**



Sheet 1 of 1  
Boring 1 of 8

**Contract No.** BA123A51      **Project Description** Example Pipe Line Project  
**Consultant** XYZ Consultants      **Geotech Consultant/Contractor** EFG Geo Consult.  
**Boring No.** BH-1      **Station** 449+00 120 L      **Ground Surface Elevation** 481.9 ft  
**Easting** 526453      **Northing** 1295426      **Logged by** M.M  
**Date Started** 7/24/06      **Date Completed** 7/24/06  
**Inspector** M.M      **Driller** M. Smith

Rig Type	Rubber Tire ATV
Rig No.	CME 750
Drive Hammer	140 LB
Casing Auger Size	3.25 IN
Size of Core	1.875 IN
Size of Bit OD	2.98 IN
Hammer Energy Ratio	65 %
Auger Depth	35 FT

WATER TABLE

Depth Below Surface	Time	Date
Depth (ft)	Elev (ft)	(hours)
▼ 23.3	458.6	0
√ 12.5	469.4	24

CAVE-IN TABLE

Depth Below Surface	Time	Date
Depth (ft)	Elev (ft)	(hours)
10.0	471.9	0 hr
15.0	466.9	24 hr

DEPTH IN FEET	ELEV. IN FEET	MATL	MATERIAL DESCRIPTION	SPT SPOON/ROCK CORE			REC (%)	LAB. INDEX TESTS			REMARKS
				SAMPLE NO.	BLOWS/RQD	SAMPLE DEPTH		NMC (%)	LL (%)	PI (%)	
4.0	477.90		Moist, Medium Stiff, Tan, SILT, Some Fine Sand	S-1	3-4-4-5	0.0-2.0	11%	20	50	12	4" Topsoil
				S-2	4-6-8-6	2.0-4.0	8%	12	30	21	
8.0	473.90		Moist, Loose, Light Brown, Medium to Coarse, SAND, Some Silt	S-3	4-5-5-6	4.0-6.0	14%	21	51	10	
				S-4	8-7-6-6	6.0-8.0	24%	10	53	12	
				S-5	2-2-4-4	8.0-10.0	24%	17	12	11	
18.5	463.40		Moist, Medium Stiff, Mottled Light Tan and White, SILT and Sand	S-6	3-3-5	13.5-15.0	18%	14	15	2	
				S-7	6-6-11	18.5-20.0	18%	12	11	3	
23.5	458.40		Same as S-5. Very Moist, Very Stiff, Trace Gravel	S-8	40-50/4	23.5-24.3	10%	19	12	3	
28.5	453.40		Wet, Very Dense, Light Tan, SAND and Silty Clay	S-9	50/4	28.5-28.8	4%		24	14	
33.5	448.40		Moist, Very Dense, Mottled Light Tan and White, SAND, Little Silt	S-10	24-22-26	33.5-35.0	15%				
35.0	446.90		Moist, Dense, Mottled Light Tan and White, Fine to Medium SAND, Trace Silt								

WSSC STANDARD BORING LOG (LETTER SIZE) / WSSC TEMPLATE.GDT / EXAMPLE PIPE LINE PROJECT.GPJ - 8/30/15

**Legend:** NMC - Natural Moisture Content    PI - Plasticity Index    REC - Recovery    MATL - Material Graphics    SPT - Standard Penetration Test  
 RQD - Rock Quality Designation    LL - Liquid Limit    Elev - Elevation    Geotech - Geotechnical    OD - Outside Diameter

Boring and Sampling  
 Complies to ASTM/AASHTO:  
 T-206



TSG/GEO/02  
9-16-2015

**WASHINGTON SUBURBAN SANITARY COMMISSION  
STANDARD TEST PIT LOG**



Sheet 1 of 1  
Boring        of 8

Contract No. BA123A51 Project Description Example Pipe Line Project  
 Consultant XYZ Consultants Geotech Consultant/Contractor EFG Geo Consult.  
 Test Pit No. TP-1 Station 474+00 110 R Ground Surface Elevation 452.3 ft  
 Easting 524513 Northing 1297010  
 Date Started 8/9/07 Date Completed 8/9/07  
 Inspector Larry M Logged by Larry. M

WATER TABLE			
Depth Below Surface		Time (hours)	Date
Depth (ft)	Elev (ft)		
▼ 8.0	444.3	0	8/9/07
▽ 7.0	445.3	0	8/9/07

DEPTH IN FEET	ELEV. IN FEET	MATL	MATERIAL DESCRIPTION	BAG/BLOCK SAMPLE		LAB. INDEX TESTS			REMARKS
				SAMPLE NO.	SAMPLE DEPTH	NMC (%)	LL (%)	PI (%)	
2.0	450.30		Dry, Medium Stiff, Reddish Brown, SILT, Trace Fine Sand (a-4)						
4.0	448.30		Same as S-1, Stiff, Little Quartz Gravel, Trace Organics (a-4)	1	2.0-4.0	30	40	10	
6.0	446.30		Same as S-1, Stiff, Trace Clay (a-4)						
10.0	442.30		Dry, Stiff, Orangish Tan, Micaceous SILT, Trace Fine Gravel, Trace Fine Sand (a-4) ▼						Water encountered 6'

WSSC STANDARD TESTPIT LOG | LETTER SIZE | WSSC TEMPLATE.GDT / EXAMPLE PIPE LINE PROJECT.GPJ - 8/30/15

SAMPLE

Legend: NMC - Natural Moisture Content PI - Plasticity Index LL - Liquid Limit Elev - Elevation MATL - Material Graphics Geotech - Geotechnical





WASHINGTON SUBURBAN SANITARY COMMISSION  
SOIL CORROSION POTENTIAL FOR METALLIC PIPES

Sheet 1 of 1

Contract No. BA123A51 Project Description Example Pipe Line Project  
 Consultant XYZ Consultants Testing Company ABC INC.  
 Checked by Bill K. Tested by Michael A  
 Date reported 11/11/2015

Boring/Test Pit ID	Depth (ft)	Resistivity, ohms-cm		PH		Redox Potential, millivolt		Chloride Content, ppm		Soil Sample Description		Sum	Soil Corrosivity
		Results	Points	Results	Points	Results	Points	Results	Points	Results	Points		
BH-1	5-7	6	10	7	0	65	3.5	9000	10	Clay(Blue-Gray)	10	33.5	Severe
BH-1	8-9	6	10	3	3	-2	5	2000	10	Clean Sand	0	28	Severe
BH-1	9-12	500	10	2	5	200	0	2000	10	Clay/Stone	5	30	Severe
BH-1	15-20	600	10	4	3	-50	3	600	6	Clay	3	27	Severe
BH-1	20-22	50	10	9	3	100	3.5	3000	10	Clay/Stone	5	31.5	Severe
BH-1	23-24	100	10	6	0	-20	5	5000	10	Clay(Blue-Gray)	10	35	Severe
BH-1	26-27	500	10	2	5	200	3	600	6	Silt	2	23	Severe
BH-1	28-30	200	10	9	3	-20	5	10000	10	Clay(Blue-Gray)	10	38	Severe
BH-1	30-32	1000	8	2	5	-51	5	8000	10	Clay/Stone	5	33	Severe
BH-1	32-35	2000	6	5	0	75	3.5	30	0	Clay(Blue-Gray)	10	19.5	Severe
BH-2	4-6	5000	4	6	0	400	0	200	4	Clean Sand	0	8	Moderate
BH-2	8-12	2000	6	1	3	100	5	100	2	Clean Sand	0	16	Severe
BH-2	10-15	6000	2	2	5	200	0	50	2	Clay/Stone	5	14	Appreciable
BH-2	20-25	10000	0	3.5	3	-50	5	62	2	Silt	2	12	Appreciable
BH-2	26-28	1000	6	3	3	100	3.5	70	2	Clean Sand	0	16.5	Severe
BH-2	29-30	10000	0	3	0	300	0	60	2	Clean Sand	0	2	Mild
BH-2	31-32	500	10	3	3	-50	5	60	2	Clean Sand	0	20	Severe
BH-2	33-35	8000	2	6	0	-80	5	60	2	Clay(Blue Gray)	10	19	Severe
BH-2	35-36	2000	6	2	5	200	0	100	2	Clay/Stone	5	18	Severe
BH-3	2-4	1200	8	5	0	10	4	300	4	Clay(Blue Gray)	10	26	Severe
BH-3	4-6	1300	8	3	3	50	4	7000	10	Clay	3	28	Severe
BH-3	6-10	2000	6	5	0	30	4	700	6	Clay/Stone	5	21	Severe
BH-3	12-15	200	10	7	0	-50	5	61	2	Clean Sand	0	17	Severe
BH-3	20-25	200	10	2	5	-30	5	70	2	Clay(Blue Gray)	10	32	Severe

Table 30 - Soil Condition Analysis: WSSC's Pipe Design Manual, 2008

RANKING SYSTEM FOR CORROSION		Points
Soil Characteristics		
1. Resistivity, Ohm-cm		
< 1,000		10
1,000 - 1,500		8
1,500 - 2,500		6
2,500 - 5,000		4
5,000 - 10,000		2
> 10,000		0
2. PH		
0.0 - 2.0		5
2.0 - 4.0		3
4.0 - 8.5		0
> 8.5		3
3. Redox Potential ( mV Vol)		
Negative		5
0 - 50		4
50 - 100		3.5
> 100		0
4. Chloride Content ( ppm)		
> 1,000		10
500 - 1,000		6
200 - 500		4
50 - 200		2
6 - 50		0
5. Soil Sample Description		
Clay ( Blue-Gray)		10
Clay/Stone		5
Clay		3
Silt		2
Clean Sand		0

Table 31 - Overall Corrosivity Rating: WSSC's Pipe Design Manual, 2008

SOIL CORROSION TOTAL POINTS	
Severe	> 15.5
Appreciable	10.0 - 15.5
Moderate	5.0 - 9.5
Mild	0 - 4.5

SOIL CORROSION SUMMARY REPORT / WSSC\_TEMPLATE.GDT / EXAMPLE PIPE LINE PROJECT.GPJ - 9/2015

